



# **What's New in Maya**

Version 6



© Copyright 2004 Alias Systems, a division of Silicon Graphics Limited ("Alias"). All images © Copyright Alias unless otherwise noted. All rights reserved.

Inside cover image created by Duncan Brinsmead.

Alias is a registered trademark and the swirl logo, the Maya logo, Conductors, Trax, IPR, Maya Shockwave 3D Exporter and MEL are trademarks of Alias in the United States and/or other countries worldwide. Maya is a registered trademark of Silicon Graphics, Inc. in the United States and/or other countries worldwide, used exclusively by Alias. SGI, IRIX, Open GL and Silicon Graphics are registered trademarks of Silicon Graphics, Inc. in the United States and/or other countries worldwide. mental ray and mental images are registered trademarks of mental images GmbH & CO. KG. in the United States and/or other countries. Lingo, Macromedia, Director, Shockwave and Macromedia Flash are trademarks or registered trademarks of Macromedia, Inc. Wacom is a trademark of Wacom Co., Ltd. NVidia is a registered trademark and Gforce is a trademark of NVidia Corporation. Linux is a registered trademark of Linus Torvalds. Intel and Pentium are registered trademarks of Intel Corporation. Red Hat is a registered trademark of Red Hat, Inc. ActiveX, Microsoft and Windows are either registered trademarks or trademarks of Microsoft Corporation in the United States and/or other countries. Mac, Macintosh and QuickTime are trademarks of Apple Computer, Inc., registered in the United States and other countries. Adobe, Adobe Illustrator, Photoshop and Acrobat are either registered trademarks or trademarks of Adobe Systems Incorporated. UNIX is a registered trademark, licensed exclusively through X/Open Company, Ltd. AutoCAD, Discreet Logic, Inferno and Flame are either registered trademarks or trademarks of Autodesk, Inc. in the USA and/or other countries. OpenFlight is a registered trademark of MultiGen Inc. Java is a registered trademark of Sun Microsystems, Inc. RenderMan is a registered trademark of Pixar Corporation. Softimage is either a registered trademark or trademark of Avid Technology, Inc. in the United States and/or other countries. All other trademarks, trade names, service marks, or product names mentioned herein are property of their respective owners.

This document contains proprietary and confidential information of Alias, and is protected by Federal copyright law and international intellectual property conventions and treaties. The contents of this document may not be disclosed to third parties, translated, copied, or duplicated in any form, in whole or in part, or by any means, electronic, mechanical, photocopying, recording or otherwise, without the express prior written consent of Alias. The information contained in this document is subject to change without notice. Neither Alias, nor its affiliates, nor their respective directors, officers, employees, or agents are responsible for any damages of any kind arising out of or resulting from the use of this material, including, without limitation, any lost profits or any other direct, indirect, special, incidental, or consequential damages or for technical or editorial omissions made herein.



**ALIAS ■ 210 KING STREET EAST ■ TORONTO, CANADA M5A 1J7**

# Table of Contents

<b>1 What's New in Maya</b> .....	<b>21</b>
Introduction to what's new in Maya 6 .....	21
Long hair and dynamic curves for Maya Unlimited .....	21
Soft Modification Tool and Deformer .....	22
Enhancements to character animation .....	23
New deformers on particles .....	23
Shader organization and filtering in Hypershade .....	24
Continued mental ray integration .....	24
Adobe Photoshop integration .....	24
Enhancements to file referencing/scene segmentation ....	25
Selective pre-loading for references .....	25
Load/unload related references in scene view .....	25
Embedded Web browser in a panel .....	25
Render Fur in mental ray .....	26
View, edit and blend between Cloth caches .....	26
Improved search and navigation in Maya Help .....	26
<b>2 General</b> .....	<b>27</b>
Wheelmouse use .....	27
Component Editor .....	27
Options menu .....	27
Layout menu .....	28
Selective file loading .....	28
Preload Reference Editor .....	30
File > Open Scene > <input type="checkbox"/> .....	31
Reference Editor changes .....	31

Selective file loading error handling .....	33
Reference locators and reference manipulation .....	33
Reference locators .....	34
File > Create Reference > <input type="checkbox"/> .....	35
Reference manipulation .....	35
Preserve references .....	36
File > Import > <input type="checkbox"/> , File > Export Selection > <input type="checkbox"/> , File > Export All > <input type="checkbox"/> .....	36
Creating references vs. importing with preserved references 36	
Exporting references: all objects visible .....	37
Optimize scene size .....	37
Speed boost .....	37
Shows progress .....	38
Interruptability .....	38
Reporting .....	38
Individual optimizations .....	39
Add custom optimizations .....	39
Default file loading .....	40
File > New > <input type="checkbox"/> .....	40
Launching images and animations from Maya .....	40
Instance improvements .....	41
Instance Leaf Nodes .....	41
Edit > Duplicate > <input type="checkbox"/> .....	41
Freeze transform now works on hierarchies containing multiple instances .....	41
Script Editor changes .....	42
Script > Suppress Command Results .....	42
Script > Suppress Info Messages .....	42

- Script > Suppress Warning Messages ..... 42
- Script > Suppress Error Messages ..... 42
- Other interface changes ..... 43
  - Hotkeys ..... 43
  - Node colors ..... 43
  - Improvements to selection of overlapping objects ..... 44
  - Outliner improvements ..... 45
- Layer Editor improvements ..... 45
- FCheck improvements ..... 46
  - Control Bar ..... 46
  - New sound capabilities ..... 47
  - New view capabilities ..... 47
  - Launch FCheck from Maya ..... 47
  - Improved help system ..... 48
- Maya Help improvements ..... 48
  - Maya Help ..... 48
  - MEL Commands, Nodes, and API reference documentation ..... 50
- Web browser in a panel ..... 51
  - Examples of workflow ..... 52
  - Maya browser controls ..... 53
  - Configuring the Maya browser ..... 54
  - Examples of MEL Commands in the browser ..... 56
  - Web browser menu items ..... 56
- 3 Modeling ..... 59**
  - Soft Modification Tool and Deformer ..... 59
    - Deform > Soft Modification >  ..... 60
    - Notes ..... 62
    - Deforming objects or components with Soft Modification 63

Polygon Mirror Cut .....	73
Poly Mirror Cut Options .....	75
Smooth Proxy .....	75
Performance improvement .....	76
Mirroring .....	76
Share Transform Node .....	80
Proxy Mesh Renderable .....	81
Hotkeys .....	81
Unmirror Smooth Proxy .....	82
Smooth UVs on non-manifold geometry .....	82
Vertex Normal Edit Tool .....	82
Vertex Normal Manip Settings .....	83
Modify Curve Tools .....	84
Lock Length .....	84
Unlock Length .....	85
Straighten .....	85
Smooth .....	87
Curl .....	87
Bend .....	88
Scale Curvature .....	88
Polygon Smooth .....	89
Subdivision Surface Polygon Proxy Mode .....	90
Polygon Bevel .....	90
Polygon Bevel Options .....	91
polyBevel node .....	93
Create Meshes Single Sided .....	93
UV Texture Editor .....	94
Pixel snap to center of pixel .....	94
Display improvements .....	94

File format support .....	94
Split Polygon Tool .....	95
Convert Polygons to Subdiv, NURBS to Subdiv .....	95
Heads Up Display .....	96
Curve/CV Selection .....	96
Convert NURBS to Polygons as Single Mesh .....	97
Scale/Rotate Components About Object Pivot Point .....	97
Merge Vertices .....	97
Rebuild Curve .....	98
Rebuild Surfaces .....	98
Sculpt Surfaces/Polygons Tools .....	98
Freeze Transformations (makelidentity) .....	98
-normal .....	99
Freeze Transformation Options .....	99
Persistence of Backface Culling and Color Per Vertex Display Settings .....	100
polyNormalPerVertex .....	100
Annotation Node .....	101
<b>4 Animation .....</b>	<b>103</b>
<b>Redesigned Trax Editor .....</b>	<b>103</b>
Improved Trax Editor .....	103
Related topics .....	104
How do I use the new Trax Editor? .....	104
New Trax Editor menu bar items .....	110
File > .....	111
Edit > .....	111
View > .....	113

List > .....	114
New Trax Editor toolbar buttons .....	114
New Trax Editor track control area .....	116
Revised Trax Editor track view area .....	118
New track hierarchy .....	118
New information displayed on clips .....	121
Additional clip functionality .....	124
<b>New Character Mapper window .....</b>	<b>134</b>
What is character mapping? .....	134
How do I map one character to another? .....	134
Workflow for mapping characters .....	137
Character > Character Mapper .....	138
Show menu .....	139
Edit menu .....	140
Fields .....	142
Buttons .....	143
Columns .....	143
<b>Redirecting motion .....</b>	<b>144</b>
What is motion redirection? .....	144
Workflow for redirecting animation .....	145
Related topics .....	146
How do I redirect the motion of an animated character? ..	146
Animation redirection example .....	148
Character > Redirect .....	160
Character > Redirect > <input type="checkbox"/> .....	160
Redirection in the Character Set Options window .....	161



<b>Miscellaneous improvements</b> . . . . .	<b>163</b>
Exposed muting in the Dope Sheet and Graph Editor . . . .	163
How do I mute or unmute a channel in the Dope Sheet or Graph Editor? . . . . .	163
How do I mute keys in the Dope Sheet or Graph Editor? . . . .	164
New ways to manipulate keys and curves in the Graph Editor . . . . .	167
Manipulate groups of keyframes . . . . .	167
Manipulate curves with the lattice manipulator . . . . .	169
Customize animation curve colors . . . . .	175
Additional time working units available . . . . .	177
Control what parts of characters are ghosted . . . . .	177
Playblast specified frames . . . . .	178
Off-screen Playblast (IRIX and Linux only) . . . . .	178
<b>Advanced additions to animation</b> . . . . .	<b>178</b>
Bake referenced animation . . . . .	178
New MEL flags for importing and exporting animation . . . .	179
Main scene animation data . . . . .	179
Referenced animation data . . . . .	179
Limitations to the new import and export animation flags . . . . .	181
How do I use these new <i>file</i> command flags? . . . . .	182
Example MEL procedure for customizing the color of multiple animation curves . . . . .	184
<b>5 Character Setup</b> . . . . .	<b>185</b>
<b>Retargeting animation</b> . . . . .	<b>185</b>
What is animation retargeting? . . . . .	185

Retargeting workflow . . . . .	185
How do I set my skeleton's neutral pose? . . . . .	186
How do I label my skeleton's joints? . . . . .	187
How do I turn the visibility of my joint labels on and off? . . . . .	191
How do I remove the labels from my joints? . . . . .	191
How do I retarget animation from one skeleton to another? . . . . .	192
Retargeting > Set Neutral Pose. . . . .	193
Retargeting > Go to Neutral Pose. . . . .	193
Retargeting > Joint Labelling . . . . .	193
Related topics . . . . .	194
Retargeting > Toggle Selected Labels . . . . .	194
Retargeting > Show All Labels . . . . .	194
Retargeting > Hide All Labels . . . . .	194
Retargeting > Rename Joints From Labels . . . . .	194
Retargeting > Label Based On Joint Names . . . . .	194
Retargeting > Retarget Skeleton. . . . .	195
Retargeting > Retarget Skeleton > <input type="checkbox"/> . . . . .	195
Neutral Pose . . . . .	196
Lower Body . . . . .	196
Upper Body . . . . .	198
Time . . . . .	201
<b>General character setup improvements . . . . .</b>	<b>201</b>
Delete all non-skin history. . . . .	201
Rigid bind allows binding to zero-weighted joints . . . . .	202
Soft bind skinning affects normals. . . . .	203
Improvements to the Component Editor. . . . .	203

- Improved performance ..... 203
- New options and layouts for smooth skinning ..... 203
- Deform > Soft Modification..... 203
- Deform points outside the lattice ..... 204
- Sculpt deform with texture map..... 205
  - How do I control a Sculpt deformer’s strength using a texture? ..... 206
  - Advanced Sculpt Deformer Attributes ..... 207
- Restrict the direction of a surface’s jiggle ..... 208
- Create a Cluster for each CV on a curve ..... 210
- 6 Dynamics ..... 211**
  - Deforming particles ..... 211
  - Per-particle field attributes ..... 212
  - Per-particle goalU/goalV attributes for poly goal objects . 213
  - Expression applied before and after dynamics..... 215
  - Multiple random number streams for particles ..... 216
  - Textured surface emission for poly surface emitters ..... 216
  - Ability to disable script output on particle events ..... 217
  - Solvers > Interactive Playback ..... 218
  - Parenting hinge constraints ..... 218
- 7 Rendering ..... 219**
  - General rendering .....219**
    - Adobe Photoshop file support ..... 219
      - Use PSD files in Maya ..... 220
      - Create a PSD file with layer sets from within Maya ..... 222
      - Sketch out guidelines (“lipstick”) for paint application . . 224
      - Update PSD textures ..... 225

PSD File Texture attributes .....	226
Create PSD Texture window .....	226
High quality interactive shading .....	228
Turn on High Quality shading .....	229
Hardware renderer Display options .....	229
Interactive Shading Mode improvements .....	231
Shading (Panel menu) > Interactive Shading > <input type="checkbox"/> .....	232
Hypershade performance improvements .....	233
Organize render nodes with Hypershade sorting bins .....	234
New menu item in Hypershade .....	237
Node filtering improvements in Hypershade .....	237
New (and support for custom) tabs in Hypershade .....	239
Hide shape and transform nodes in Hypershade .....	240
Test textures (and texture ranges) .....	242
Limitations and conditions .....	242
Disable the initial load of a file texture image .....	245
Improved ability to use image sequences .....	245
New image plane and File texture attributes .....	246
New command line render utility .....	247
<b>Maya software rendering .....</b>	<b>248</b>
New color utility nodes .....	248
Input and Output ranges .....	249
remapValue utility .....	250
remapColor utility .....	251
remapHsv utility .....	251
Imported shading network optimizations .....	252
Maya can now recognize new IMF plug-ins .....	253

Transfer surface information . . . . .	253
Transfer Surface Information Options . . . . .	254
<b>Maya hardware rendering . . . . .</b>	<b>257</b>
Performance improvements for hardware rendering. . . . .	257
Improved hardware plug-in shader support . . . . .	257
API plug-in development considerations . . . . .	258
Color per vertex now supported by hardware renderer. . . . .	259
Implementation details . . . . .	260
Polygon object attributes (Mesh Component Display section)	261
New performance-enhancing render globals . . . . .	262
New hardware render global settings . . . . .	262
<b>mental ray for Maya rendering . . . . .</b>	<b>264</b>
mental ray shader manager . . . . .	264
Window > Rendering Editors > mental ray > Shader Manager	265
Simplified shader connection workflow . . . . .	265
IPR rendering with mental ray for Maya . . . . .	265
Limitations . . . . .	266
mental ray for Maya command line options . . . . .	267
Support for Maya Fluids . . . . .	267
Limitations . . . . .	268
Support for Maya Fur . . . . .	268
Integrated contour rendering . . . . .	268
Contours (Render Global Settings window) . . . . .	269
Flag objects to participate in contour rendering (object Shading Group) . . . . .	275

- Render blurry reflections and refractions . . . . . 276
- Rendering Image-Based Lighting (sky-like illumination) . . 278
  - How image-based lighting works . . . . . 279
  - Position an IBL texture . . . . . 281
  - IBL node attributes . . . . . 281
- Photon and Final Gather visualization maps. . . . . 286
  - mapVizShape node . . . . . 287
- Render shader glow. . . . . 288
- Render particle motion blur . . . . . 288
- Improved Lightmap/CPV generation time . . . . . 288
- Light linking . . . . . 288
  - Light-linking for mental ray shaders . . . . . 288
  - Light-linking on particle instances . . . . . 289
- Support for diagnostics. . . . . 289
- Better support for mental ray texture formats . . . . . 289
- New support for triangle export of polygon meshes . . . . . 290

**8 Painting . . . . . 291**

- Paint Effects on Polygons . . . . . 291
- UV linking for Paint Effect on polygons . . . . . 291
- Isolating Paint Effects strokes for rendering . . . . . 291
- Progress indicator for rendering Paint Effects . . . . . 291
- Artisan Tools ported to the new architecture . . . . . 292
- New Paint Hair Tool. . . . . 292
- New Paint Cloth Collision Properties Tool. . . . . 293
- Sculpt Surfaces Tool improvements . . . . . 293
- Paint Scripts Tool improvements . . . . . 293
- Paint Sculpt Map . . . . . 293

**9 Fluid Effects . . . . . 295**

**Fluids cache performance enhancements. . . . .295**

        Control the creation of temporary fluids cache files. . . . . 295

        Save one fluids cache file per frame . . . . . 296

            How do I create an One Frame per File fluids cache? . . . 298

        Advanced Fluids Caching in MEL . . . . . 299

            Example . . . . . 301

**Troubleshooting the Fluids cache. . . . .301**

        Maya cannot read the fluids cache. . . . . 301

            There is not enough space in your temp directory . . . . . 302

            The fluids cache is on a remote network drive that you are  
            unable to access . . . . . 303

        Maya cannot find the current fluids cache . . . . . 303

        Maya is unable to create a playback cache for the current fluid  
        . . . . . 304

            There is not enough space on the specified disk . . . . . 304

            When saving fluids caches on Windows or Linux systems,  
            the resulting files are incomplete or contain blank frames  
            . . . . . 305

**General Fluids improvements . . . . .305**

        Fluids render in mental ray for Maya. . . . . 305

        Replace Cache Frame . . . . . 306

        Easily view fluids cache contents . . . . . 306

**10 Fur . . . . . 309**

    Rendering Fur in mental ray . . . . . 309

        Rendering in the Maya software renderer vs. mental ray for  
        Maya . . . . . 311

- New Render Stats in Fur Feedback Shape node . . . . . 314
- New mental ray Fur rendering options . . . . . 315
- Fur Equalizer Maps improvements . . . . . 317
  - New Custom Equalizer Maps option . . . . . 317
  - Changes to Read Equalizer Maps option . . . . . 318
- Fur on Subdivision Surfaces. . . . . 319
- Paint Fur Attributes Tool improvements . . . . . 319
- Update maps for referenced scenes or externally painted fur attributes . . . . . 320
- Fur Feedback improvements . . . . . 320
  - Hiding and showing Fur Feedback . . . . . 320
  - Switching between Fur Feedback . . . . . 321
  - Transforming Fur . . . . . 322
- Effect of lighting intensity on Fur . . . . . 322
- Reverting to former Maya Fur behavior . . . . . 322

**11 Cloth . . . . . 325**

- Improved support for Cloth objects . . . . . 325**
- Improvements for Cloth objects . . . . . 325
- Constraints on Cloth objects . . . . . 326
- Cloth object resolution . . . . . 326
- Cloth UV set . . . . . 327
- Painting cloth object properties . . . . . 327
- Painting collision object properties . . . . . 327
- Vertex level cloth properties . . . . . 329
  - cpProperty node . . . . . 331
- Removing cloth properties . . . . . 332
- Painting tessellation on garments and panels . . . . . 332



Visualizing Cloth stress . . . . .	333
cpClothStress node . . . . .	334
Per-face collision depth . . . . .	336
Stitch attribute for Cloth constraint . . . . .	337
Mesh constraint improvements . . . . .	338
Solver performance improvements . . . . .	338
Solver hang detection . . . . .	339
Monitor script parameters . . . . .	340
Reasons for solver failure . . . . .	341
Solver diagnostics . . . . .	342
Advanced Cloth cache editing . . . . .	343
Multiple caches . . . . .	344
Editing caches . . . . .	344
Simulation > Cache Editor . . . . .	348
<b>12 MEL . . . . .</b>	<b>351</b>
Changes to MAYA_SCRIPT_PATH . . . . .	351
New and improved commands . . . . .	351
General . . . . .	351
Modeling . . . . .	354
Animation . . . . .	354
Painting . . . . .	354
Rendering . . . . .	355
Cloth . . . . .	355
Converting between vector and float arrays . . . . .	356
Script node improvements . . . . .	356
Multiple random number streams . . . . .	357
Selective load of references . . . . .	358
Additional information . . . . .	359

Paint Scripts Tool improvements . . . . .	360
Customizing Optimize Scene Size . . . . .	360
New webBrowser command . . . . .	363
<b>13 Translators . . . . .</b>	<b>365</b>
Image file support . . . . .	365
DWG translator improvements. . . . .	365
New IGES import/export options . . . . .	365
STL import . . . . .	367
IgesDxftoMaya removed. . . . .	367
OpenFlight on Mac OS X. . . . .	367
StudiolImport on Mac OS X. . . . .	368
<b>14 API and DevKit . . . . .</b>	<b>369</b>
<b>API . . . . .</b>	<b>369</b>
Improvements to the Maya API . . . . .	369
New classes and header files . . . . .	369
Classes . . . . .	369
Headers . . . . .	370
Changes to existing classes . . . . .	370
M3dView . . . . .	370
MAnimControl . . . . .	371
MDagMessage . . . . .	372
MDagPath . . . . .	373
MFloatVector and MVector . . . . .	373
MFnArrayAttrsData . . . . .	373
MFnCamera . . . . .	374
MFnClip . . . . .	374
MFnDagNode . . . . .	375

MFnDirectionManip .....	375
MFnDoubleIndexedComponent .....	376
MFnFluid .....	376
MFnFreePointTriadManip .....	376
MFnManip3D .....	376
MFnNurbsCurve .....	377
MFnNurbsSurface .....	377
MFnParticleSystem .....	377
MFnPlugin .....	378
MFnSubd .....	378
MIOStream .....	379
MLibrary .....	379
MLightLinks .....	379
MMessage .....	380
MNodeMessage .....	380
MPxFieldNode .....	381
MPxManipContainer .....	381
MPxNode .....	382
MRenderView .....	382
MRenderUtil .....	383
MSelectionMask .....	383
MString .....	383
MTime .....	384
MPxHwShaderNode .....	385
Examples of new plug-in functionality .....	386
affectsNode .....	386
blastCmd .....	386
componentScaleManip .....	386
customAttrManip .....	386
deleteMsgCmd .....	386

dynExprFieldTest .....	386
fluidInfoCmd .....	386
instanceCallbackCmd .....	387
nodeCreatedCB .....	387
particlePathsCmd .....	387
polyMessageCmd .....	387
progressWindowCmd .....	387
renderViewInteractiveRenderCmd .....	387
rotateManip .....	387
surfaceBumpManip .....	388
undoRedoMsgCmd .....	388
userMsgCmd .....	388
Other significant changes .....	388
Compiler requirements .....	389
<b>Devkit .....</b>	<b>390</b>
Maya lists new IMF plug-ins .....	390
<b>Index .....</b>	<b>391</b>

# 1

# What's New in Maya

## Introduction to what's new in Maya 6

This book describes the new features we've added in Maya 6. For your convenience, we've included complete procedures for using the new features in this book. You can also find the information on the new features in the Maya Help.

All features are common to all four platforms—Windows, Mac OS X, Linux, and IRIX—unless otherwise indicated. Some features—Fluid Effects, Cloth, Fur, Live, and Hair—are only found in Maya Unlimited, which is available on Windows, Linux, and IRIX platforms.

The following sections contain descriptions of some of the major features and improvements.

## Long hair and dynamic curves for Maya Unlimited

Maya Unlimited 6 introduces Hair, a major new feature set that combines a dynamic curve simulation engine with a variety of rendering options for the creation of hair and other objects, such as ropes, chains, feathers and vines. The simulation engine can also be used to control NURBS curves connected to other objects, such as IK chains, surfaces, emitters, and deformers.

## 1 | What's New in Maya

### > Soft Modification Tool and Deformer

Using Hair, you can easily and quickly create realistic hair on characters directly within Maya that:

- reacts to character motion and dynamic forces, such as wind
- can collide with objects, like shoulders
- can be constrained into hairstyles, such as ponytails, braids or hair clips



The dynamic curves can also be used to create a huge range of other effects, such as suspension bridges, octopi, curtains, fishing lines, and much more.

For more information, see “*Hair overview*” in the online Hair and Dynamic Curves guide.

## Soft Modification Tool and Deformer

This new feature combines selection with manipulation. You can move, scale and rotate a selection with customizable falloff. The *tool* mode does not create history unless the original object has history: it is available from the Tool Box. The *deformer* mode creates history which can be edited after the fact and animated. Deformation weights can be painted using the Paint Attributes Tool.

With the Soft Modification Tool you can quickly manipulate geometry in an intuitive manner, similar to sculpting with clay. You can subtly blend changes with the surrounding geometry by controlling the falloff. For more information, see "Soft Modification Tool and Deformer" on page 59.

## Enhancements to character animation

Maya 6 offers substantial enhancements to character animation. Trax has been redesigned and streamlined to provide enhanced productivity and ease-of-use. With new Motion Retargeting, motion capture or other animation data can be adapted and reused on different characters, removing the necessity to generate original data for each character. With new Motion Redirection, you now have the ability to redirect motion capture or other animation data that facilitates the reuse of stock or pre-existing data for new purposes.

### Related topics

- ❖ "Improved Trax Editor" on page 103
- ❖ "What is animation retargeting?" on page 185

## New deformers on particles

Nearly all deformers, such as lattices, clusters, and non-linears, can now be used on particles, just as they can on geometry. This provides powerful control over particle simulations, particularly useful for situations that defy physical reality, such as a wisp of smoke coiling around a character. For more information, see "Deforming particles" on page 211.

## 1 | What's New in Maya

> Shader organization and filtering in Hypershade

### Shader organization and filtering in Hypershade

You can now organize render nodes into sorting bins. You can also filter nodes by name or type, with a separate filter for each Hypershade tab. These tools allow you to better manage and organize complex scenes with large numbers of shaders and associated nodes. Render nodes can be categorized logically, and therefore located more quickly, streamlining your workflow.

#### Related topics

- ❖ "Organize render nodes with Hypershade sorting bins" on page 234
- ❖ "Node filtering improvements in Hypershade" on page 237

### Continued mental ray integration

We've continued to integrate mental ray more completely with Maya, adding support for Maya-specific features and making underlying functionality more accessible.

### Adobe Photoshop integration

We've added several features which allow you to work directly with PSD files within Maya. This enables tighter, more efficient workflows with the most commonly used texturing tool for Maya. For more information, see "Adobe Photoshop file support" on page 219.



## Enhancements to file referencing/scene segmentation

### Selective pre-loading for references

You now have control over which references, at all levels in the hierarchy, you want to load with your file upon opening. By saving out the selective load settings with a given file, or building a set before opening the file, you can cut down on the time it takes to open the file by only loading reference files of interest. For more information, see "Selective file loading" on page 28.

### Load/unload related references in scene view

You can now create references with an associated annotated locator that is visible in the scene view. From this locator, you can load and unload the related reference. This allows you to better manage complex scenes, by making it easier to visually select parts of the scene for loading and unloading. For more information, see "Reference locators and reference manipulation" on page 33.

### Embedded Web browser in a panel

This applies to Windows, Mac OS X and Linux only. You can now use a Web browser within a Maya panel to browse through and view Web content, or to issue MEL commands from an HTML page.

The Web browser can be used simply for displaying documentation (either internal or external to Maya), but since it can execute MEL commands it can also be used to build user interfaces or interactive tutorials, or to manage assets and scene data. This will facilitate the integration of intranet infrastructure tools directly into Maya.

For more information, see "Web browser in a panel" on page 51.

## 1 | What's New in Maya

### > Render Fur in mental ray

## Render Fur in mental ray

You now have the option to render Fur in the mental ray renderer. The Fur is created using mental ray's hair primitive and renders in the main render pass. Since it is not a post-process, Fur rendered in mental ray behaves like any other object in the scene:

- it can show up in reflections and refractions, through transparent objects, and can take advantage of global illumination and caustics
- lighting, shadows and motion blur match the rest of the scene perfectly
- artifacts caused by z-depth compositing are no longer an issue

For more information, see "Rendering Fur in mental ray" on page 309.

## View, edit and blend between Cloth caches

This includes support for multiple Cloth caches per node and the implementation of core editing functions such as copying, blending and interpolation. This allows you to easily compare different simulations, to select the best parts of each and blend between them to produce the best possible overall result. For more information, see "Advanced Cloth cache editing" on page 343.

## Improved search and navigation in Maya Help

The Maya Help now has improved search, index, navigation and layout, letting you more easily find what you're looking for. For more information, see "Maya Help improvements" on page 48.

# 2

# General

## Wheelmouse use

Maya now supports the use of scrolling wheels on mouse input devices. This feature allows you to:

- dolly in perspective or orthographic views
- zoom in the Hypershade, Graph Editor, Dope Sheet, Render View, Paint Effects, and other windows and editors
- scroll in the Script Editor and Console window

## Component Editor

The Component Editor's performance has been improved, especially on large component sets.

We have added several display options. Instead of one List menu, there are now two menus, Options and Layout, and there are four new menu items: Hide Zero Columns, Sort Alphabetically, Show Selected Columns, and Show Selected Objects.

## Options menu

- Auto Update
- Hide Zero Columns (New)

When this item is turned on, all columns whose values are zero are hidden (for example, a joint with no influence on vertices in the Smooth Skins tab). When this item is turned off, columns whose values are zero are shown.

- Sort Alphabetically (New)

## 2 | General

### > Layout menu

When Sort Alphabetically is turned off, the items that make up the columns are displayed in their order in the hierarchy. When Sort Alphabetically is turned on, the items are sorted in alphabetical order.

- Show Path Name
- Change Precision

### Layout menu

- Load Selected Components
- Show Selected Columns (New)

Removes all columns from the view, except those which are selected. This gives you a way to specify a set of influences/joints and view only them.

- Show Selected Objects (New)

Allows you to view only those components which are influenced by a selected object.

For example, create a Smooth Skinned object and select all of its CVs. The Component Editor shows all the CVs. If you select one of the influences and choose Show Selected Objects, you'll see only CVs for that influence; the others will be hidden.

- Show All Columns

### Selective file loading

In Maya 6 you now have control over which references, at all levels in the hierarchy, you want to load with your file upon opening.

We're introducing a new concept—*selective load settings*—that refers to the state of reference loading when the top-level file of a series of referenced files is saved. This improves file opening performance in large scenes.

By saving out the selective load settings with a given file, or building a set before opening the file, you can cut down on the time it takes to open the file by only loading reference files of interest.

The workflow is the following:

- 1** Decide if you want to open a file with references with the default (previous) selective load settings or if you want to specify which references to load when you open the file.
- 2** Do one of the following:
  - To open the file with the default settings, select File > Open and then select the file. Any referenced files that were saved as loaded with this file last time will be loaded now.
  - To specify which references to load, select File > Open >  and turn on Selective Load. Then click Open and select your file. The Preload Reference Editor appears. In this editor, specify which references to load. See "Preload Reference Editor" on page 30.
  - To open a file with no references loaded, select File > Open >  and turn on Load No References. Then click Open and select your file, which is opened with no references loaded. (You can also Load All References, an option which was available in previous Maya releases.)
  - Use the MEL `file` command with new selective load of reference flags. See "Selective load of references" on page 358.

<b>Note</b>	Selective file loading works fastest when your file is saved with all references unloaded. File > Save As now has an Unload References option to facilitate this.
-------------	---

## 2 | General

### > Preload Reference Editor

## Preload Reference Editor

The Preload Reference Editor looks very much like the Reference Editor. It appears when you open a file when the Selective Preload option is turned on in the File > Open >  window.

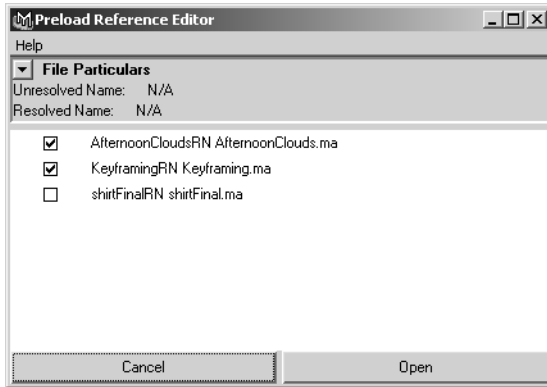

### To select which references will be read in (loaded) and which deferred (unloaded)

- 1 Select one or more items in the Preload Reference Editor.
- 2 Do one of the following:
  - Click the checkbox next to each item.
  - Right-click an item and select Bring in Reference Loaded or Bring in Reference Unloaded from the menu that appears.

**Note** Loading and unloading references works hierarchically; that is, switching the top-level load status of a parent to unloaded means that all children references are also not loaded.

## File > Open Scene >

There are two new options in File > Open Scene > .

### Load No References

This opens the file without loading any references. You can load references after the file is open in Maya by opening the Reference Editor (File > Reference Editor) and selecting the references you want to load.

### Selective Preload

Selecting this option opens the Preload Reference Editor before opening any file. You can choose to load or defer any references in the file.

❖ “Preload Reference Editor” on page 30

## Reference Editor changes

- You can now edit reference paths in the Reference Editor, which allows you to specify a reference using relative paths and environment variables.

Enter an environment variable or relative path in the Unresolved Name text box of the Reference Editor, and click Reload to load the reference from that location.

## 2 | General

### > Reference Editor changes

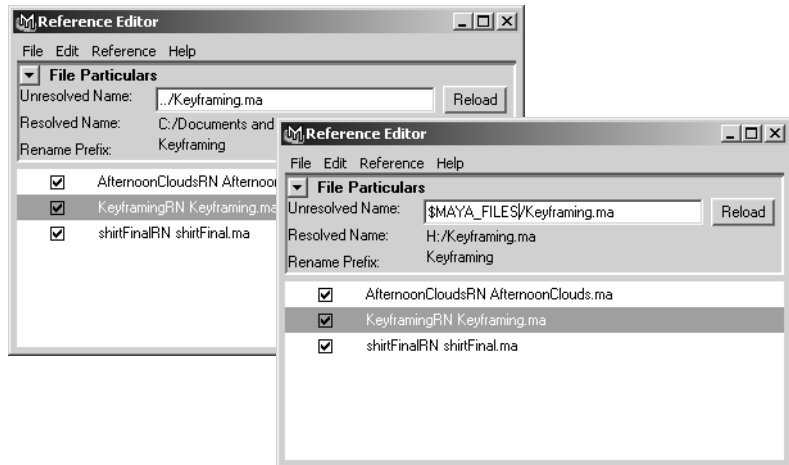

If Maya can't find the referenced file in the specified location, it looks in several default locations to find the file.

- We have removed a number of the fields in the File Particulars section of the Reference Editor because they were uninformative.
- There is a new column of icons to switch the loaded/unloaded state of a reference in memory.
- There are two new items in the Reference menu:
  - Load Related References. This loads references related to all selected objects.
  - Unload Related References. This unloads references related to all selected objects.
- You can select multiple items in the Reference Editor and apply most operations to them (for example, loading and unloading references).



## Selective file loading error handling

We've improved error handling for missing references. An warning dialog box appears if Maya cannot locate one or more references when opening a file.

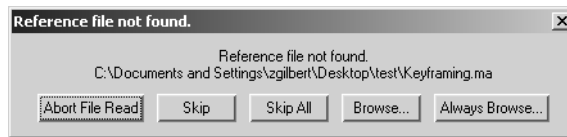

You can choose to do one of the following:

- **Abort File Read** – Stops the file read operation. If a nested reference is being read, Abort File Read aborts the reference file read but may not stop the top level File Open operation.
- **Skip** – Skips the current missing reference (and all other references to the same file).
- **Skip All** – Skip this and all future missing references without showing the dialog box again.
- **Browse** – A file browser dialog box appears, allowing you to find the missing reference. If found, the new location is used for all references to that missing file.
- **Always Browse** – A file browser dialog box appears for this and all future missing references without showing this dialog box again.

## Reference locators and reference manipulation

You can create references with a *locator*, which names and shows the location of a reference. You can also manipulate references in the modeling view.

## 2 | General

### > Reference locators

## Reference locators

When you create a grouped reference with a locator, you can see and transform the locator in the modeling view whether the reference is loaded or not.

**Note** To have a locator on a reference, you must have created the reference with the Group and Locator options turned on in the Create Reference Options dialog box. See "File > Create Reference >  " on page 35.

References display in Maya with an RN suffix.

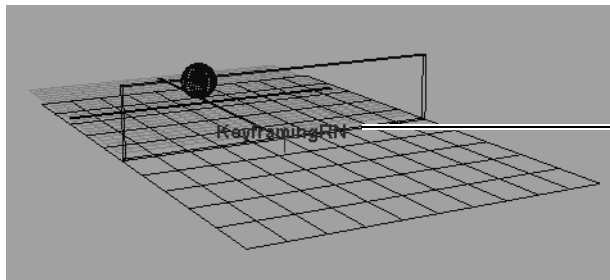

Locator of a loaded reference

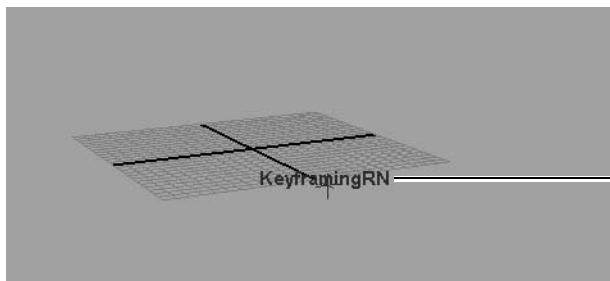

Locator of an unloaded reference

## File > Create Reference > □

There is one new option in File > Create Reference > □.

### Locator

When used with the Group option, groups the contents of the referenced file under a locator, annotated with the reference node name. The reference node has a message connection to the locator's transform.

## Reference manipulation

You can manipulate references on the locator or the reference contents.

### **To load an unloaded reference**

- 1 Select the locator of an unloaded reference.
- 2 Right-click the locator and select Load Related Reference.  
The reference appears within the Maya scene.

You can also select Load Related Reference from the Reference Editor.

### **To unload a reference**

- 1 Select a loaded reference.
- 2 Right-click geometry or the locator of the reference and select Unload Related Reference.

The reference disappears from your Maya scene. If you added the reference with a locator, the locator continues to be visible.

You can also select Unload Related Reference from the Reference Editor.

## 2 | General

### > Preserve references

#### To reload a reference

- 1 Select a loaded reference.
- 2 Right-click the reference and select Reload Related Reference.

## Preserve references

You can now select Preserve Reference when importing and exporting a file.

**File > Import > , File > Export Selection > ,  
File > Export All >**

There is one new option in File > Import > , File > Export All > , and File > Export Selection > .

#### Preserve References

If Preserve References is turned on, the references within the imported or exported file are preserved. If it is turned off, all references are imported into or exported within the file; that is, they are no longer references, but are now objects in the scene. The default is off.

## Creating references vs. importing with preserved references

Importing with preserved references behaves differently than creating a reference. When creating a reference, the reference file is parented under the main scene file and the reference objects in the referenced file are children.

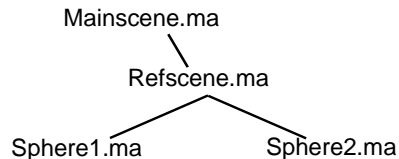

However, importing references forces the references in the imported file to be children of the main scene file; that is, there is no additional reference node created.

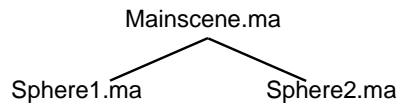

## Exporting references: all objects visible

Because Maya is storing a reference in the exported scene, all of the objects in the reference file will be visible in the exported file. That is, if you attempt to export a single object from a referenced file with two objects while preserving references, both of those objects will be visible when loading the exported file.

## Optimize scene size

The following improvements were made to the Optimize Scene Size menu item.

### Speed boost

The Optimize Scene Size menu item is faster by 2-10 times, depending on the scene. In addition, the new progress reporting and interruptability features make it feel more responsive than before.

## 2 | General

> Shows progress

### Shows progress

Maya now shows its progress as it optimizes. While Optimize Scene Size is running, the Command Line shows a progress bar for each optimization step.



### Interruptability

You can press Esc at any time to interrupt the Optimize Scene Size process. If you're interrupting a series of optimization steps, a dialog box appears asking you if you want to continue or abort.

(Restarting an interrupted optimization step produces the same result as if the step was run fully through the first time.)

### Reporting

In the Script Editor, you get a list of all operations performed during optimization, and a final summary of all optimizations. For example:

```
[...]  
Removing empty sets  
-----  
delete "__PrenotatoPerDuplicare_sine2Set8";  
delete "tankRoll";  
delete "tweakSet51";  
delete "tweakSet52";  
  
[...]  
  
Optimize Scene Size Summary:  
-----  
- Removed 0 invalid NURBS curves and surfaces  
- Removed 0 unused constraints  
- Removed 0 unused pairBlends
```

- Removed 119 unused deformers
- Removed 185 unused groupID nodes
- [...etc....]

## Individual optimizations

In the Optimize Scene Size options dialog box, you can click buttons to run different types of optimizations individually.

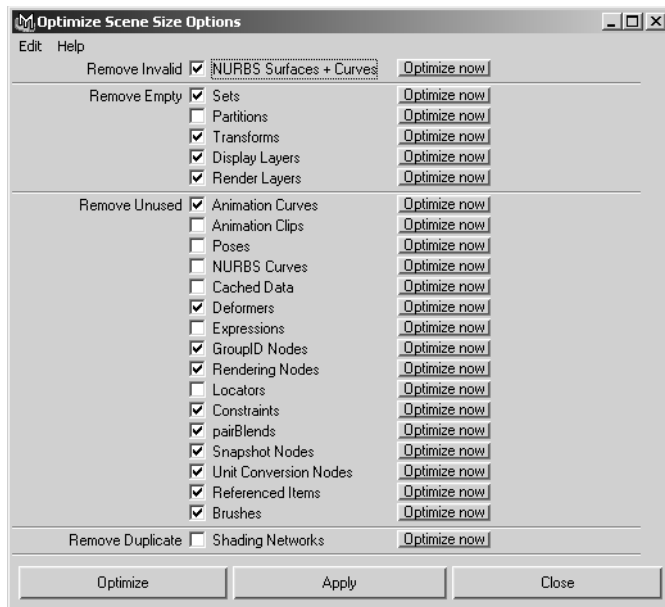

## Add custom optimizations

Customizing this dialog box is done through the use of several MEL procedures. For more information, see "Customizing Optimize Scene Size" on page 360.

## 2 | General

### > Default file loading

## Default file loading

We've added options to File > New Scene that allows a default file to be loaded when you select New Scene.

An example for using this is a default lighting rig. If you constantly create the same rig, the rig can be saved to a file and automatically loaded when you create a new scene.

### File > New >

There are two new options in File > New Scene > .

#### Enable Default Scene

Turning on this option allows you to choose a file to be loaded into the scene whenever a new scene is created.

#### Default scene

Click the folder (browse) icon and select a Maya file.

## Launching images and animations from Maya

There are two new menu items: File > View Image and File > View Sequence. These allow you to view an image or image sequence from within Maya.

When you select one of these menu items, a file browser appears and you can select the image or image sequence to view. The image or image sequence is then displayed in FCheck.



## Instance improvements

### Instance Leaf Nodes

We have added a new option that allows you to duplicate entire node hierarchies except for the leaf nodes, which are instanced to the original hierarchy.

#### **Edit > Duplicate > □**

##### Instance Leaf Nodes

Duplicate entire node hierarchies except for the leaf nodes, which are instanced to the original hierarchy. The new menu item is an improvement over the existing instance menu item, in that all dynamic attributes on the non-leaf nodes are properly duplicated into the new hierarchy.

### Freeze transform now works on hierarchies containing multiple instances

We have modified the Freeze Transformations menu item so that it functions on hierarchies that contain multiply-instanced shapes or transforms.

Previously, this function could not be run on hierarchies that contained multiple instances. Now, this menu item freezes as much of the hierarchy as is possible given the instancing structure. After this operation, all transforms in the selected hierarchy will be set to the identity except in branches of the hierarchy that are multiply-instanced. When such unfreezable branches are encountered, Maya warns you which nodes were not frozen.

## 2 | General

### > Script Editor changes

## Script Editor changes

We have made changes that let you filter the output of the Script Editor in a more finely-grained way than was previously possible. You can choose to not show command results, info messages, warning messages, or error messages. (You cannot choose to suppress the output of print or eval echo.)

We have added four commands to the Script menu of the Script Editor:

### Script > Suppress Command Results

When turned on, the Script Editor does not show the result of commands. Result messages start with `// Result:`.

### Script > Suppress Info Messages

When turned on, the Script Editor does not show informational messages. Informational messages are of many different types and do not have a set prefix (except for `//`).

### Script > Suppress Warning Messages

When turned on, the Script Editor does not show warning messages. Warning messages start with `// Warning:`.

### Script > Suppress Error Messages

When turned on, the Script Editor does not show error messages. Error messages start with `// Error:`.

The script editor menu items can also be controlled through the `scriptEditorInfo` command (`-sr/suppressResults`, `-si/suppressInfo`, `-sw/suppressWarnings`, `--se/suppressErrors`).

---

**Note** Suppressing Script Editor messages does not suppress messages from appearing in the Help Line.

---

## Other interface changes

### Hotkeys

New hotkeys allow you to change the user interface quickly:

- Ctrl+Space switches between the standard view and a full-screen view of the current panels (the Status Line, Shelf, Tool Box, Time Slider, Channel Box, Attribute Editor, etc. are hidden).
- Alt+B changes the background color of the perspective and orthographic panels: standard (light gray), dark gray, or black.

---

**Note** You may need to go to the Hotkey Editor (Window > Settings/Preferences > Hotkey) and reassign the hotkeys (Alt+B, Ctrl+Space) to their current values in order to use these hotkeys in your Maya setup.

To do so, use the following buttons: Query on the hotkey assignment, Find that assignment, and click Assign again.

---

### Node colors

You can change the color of nodes as they display in the Hypergraph.

## 2 | General

> Improvements to selection of overlapping objects

### To change a node color

- 1 In the Attribute Editor for that node, go to Drawing Overrides. You may have to expand Object Display to see this section.
- 2 Turn on Enable Overrides.
- 3 Set a color using the color slider.

You must have Node Display Override Color turned on in the Hypergraph to display color changes.

Changing the color of a layer overrides this node display setting.

The Drawing Override options allow you to change the display of the object in Maya: you can turn off the display of shading, texture, animation playback or whether that object is visible in the interface. As well, you can turn the object into a template or reference, and set the level of detail visible.

### Improvements to selection of overlapping objects

The pop-up menu that appears when you try to select overlapping objects has been improved.

**Note** You must turn on Pop-up Menu Selection in the Selection section of Window > Settings/Preferences > Preferences to see this pop-up menu.

- Your selection now is highlighted in the scene view as you select an item in this list.

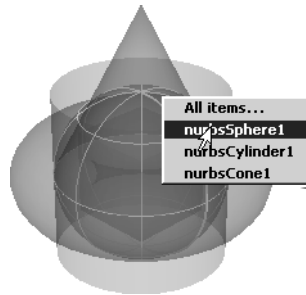

- Currently-selected items are marked with a box when the list appears.

**Note** You must hold down the left mouse key on Linux and IRIX to select an item in this list.

## Outliner improvements

You can now select User Defined from the Show > Attributes menu in the Outliner to show user-defined attributes.

## Layer Editor improvements

In the Layer Editor (which displays along with the Channel Box), there are now new options and commands:

- Layer > Create Layer now has options, which allow you to:
  - set the name and number of the layer you're creating.
  - make the created display layer current.
  - decide what to add to the layer you're creating (Nothing, Selected objects, or Selected objects and all their Children).

## 2 | General

### > FCheck improvements

- Layers > Delete Unused Layers immediately deletes layers with no content.
- Layer > Sort Layers Alphabetically allows you to sort layers by name.
- Layer > Sort Layers Chronologically allows you to sort layers by the time they were created.

## FCheck improvements

We have made the following improvements to FCheck on Windows.

### Control Bar

FCheck now has a Control Bar.



Use the Control Bar buttons for the following:



Go to first frame.



Go back one frame.



Play backwards. (Changes to Stop when playing backwards.)



Play forward. (Changes to Stop when playing forward.)



Go forward one frame.



Go to last frame.



Shows frames per second.



Show alpha channel.



Show all channels.



Show Z buffer.

You can turn the Control Bar on and off using the View > Control Bar menu item.

## New sound capabilities

FCheck can import sound files, associate them with an image sequence, and play them back in sync with your image sequence. To import a sound file, select File > Import Sound. To turn sound on or off, select File > Toggle Sound.

## New view capabilities

You can display your image at full screen size by choosing View > Full Screen.

## Launch FCheck from Maya

You can now launch FCheck from within Maya by selecting File > View Image, or File > View Sequence.

## 2 | General

> Improved help system

### Improved help system

FCheck has an improved help system available from the Help menu of FCheck.

### Maya Help improvements

Maya Help and the MEL/Nodes/API reference documentation have new layouts with improved navigation and search.

### Maya Help

#### Navigation

Maya Help now displays an improved navigation pane on the left with content appearing on the right.

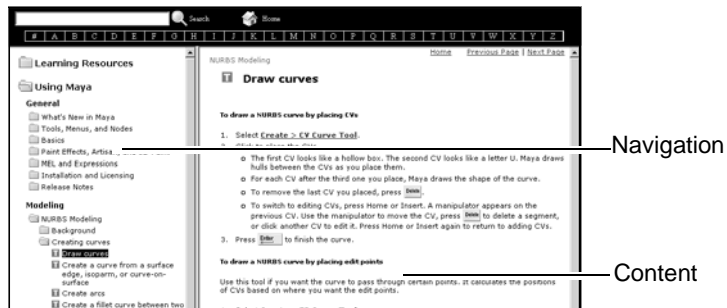

#### Search

The Maya Help search now supports intelligent matching and wild cards, provides improved search ranking, and displays Information and Tutorials separately, letting you more easily focus your search.



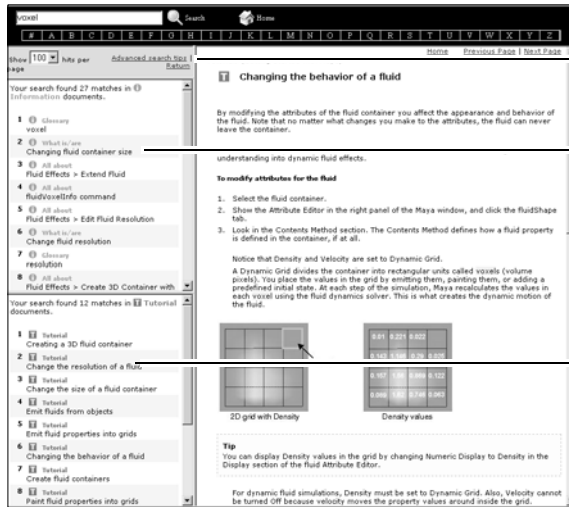

Search Tips

Information

Tutorials

## Index

Maya Help now includes an alphabetical list for easy access to the index.

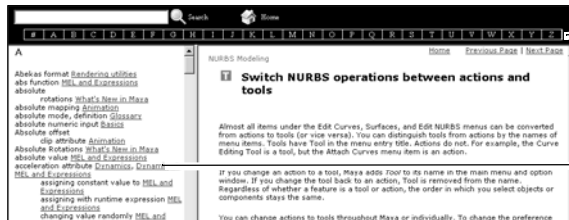

Clicking a letter...

...displays the index

## Information and Tutorials

Maya Help content is now classified as *Information* or *Tutorials*. An icon identifies each topic as either Information or Tutorial. These icons are used throughout the Maya Help, letting you more easily find what you're looking for.

## 2 | General

> MEL Commands, Nodes, and API reference documentation



Information topics include definitions of Maya terminology, overviews of 3D concepts and Maya features, detailed descriptions of Maya features, and new features and improvements in Maya.



Tutorial topics include step-by-step instructions or lessons.

### MEL Commands, Nodes, and API reference documentation

The technical reference documentation—MEL Commands, Nodes, and API—have improved navigation including:

- look and feel improvements
- two-frame navigation (top navigation, bottom content)
- four-column lists of MEL commands and nodes; two-column lists of API classes
- improved alphabetical navigation
- added Fn, It, and Px alphabetical categories for API
- improved categorization for Command documentation including a new Curves category
- substring search

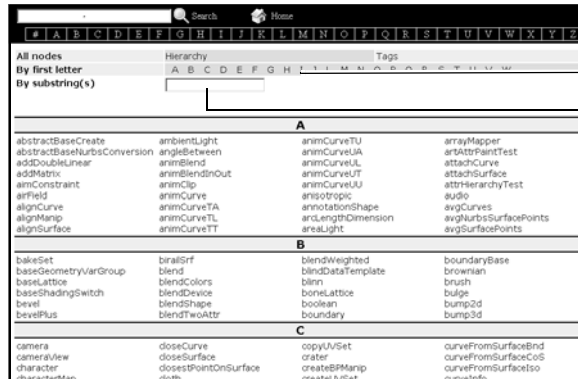

Alphabetical

Substring search

## Web browser in a panel

*This feature is supported on the Windows, Mac OS X, and Linux platforms.*

You can now use a Web browser within a Maya panel to browse through and view Web content, or issue MEL commands from an HTML page. This makes it possible to integrate Internet solutions into your Maya workflow.

This browser uses Gecko as a layout engine, employing Mozilla Open Source to properly display W3C compliant Web content. This means that you can add plugins to view Flash movies or do any of the other activities you're used to doing from a Web browser window, all from a panel within the Maya interface. Just like any other Maya panel, the Maya browser can be placed in the main Maya window beside other panels, or into a separate window.

The Maya browser does not provide all of the features supported by your current Web browser, and is not intended as a replacement. For example, it won't create multiple windows or popup windows, so links that create and open new windows will not work. As well, secure sites are not supported for this release.

## 2 | General

### > Examples of workflow

## Examples of workflow

The Maya browser makes it easier for you to view Web content while you work in Maya, without having to flip between browser windows and the Maya interface. Some examples of what you can view from within your Maya window include:

- Help and tutorials, with the Maya interface in front of you to use while you follow instructions or look for interface controls
- Flash content that you've exported from Maya
- 2D images from the Internet (or from your organization's intranet) that you can compare with models you are creating in Maya
- Project criteria on the Web that you're using to construct models, animations, and renderings

By issuing MEL commands from the Maya browser, you can:

- Design your own user interface for Maya using HTML and JavaScript
- Set up multiple controls (widgets) within HTML pages for easy reference, comparison, or tweaking of Maya characters
- Set up custom MEL tools to share over the Internet, or to interface with custom pipeline tools such as render farms

### **To access the Maya browser**

**1** Do one of the following:

- From any Maya panel, select **Panels > Panel > Web Browser**. The browser appears in the Maya panel.



- Right-click a Quick Layout button and select the Web Browser Panel menu item:

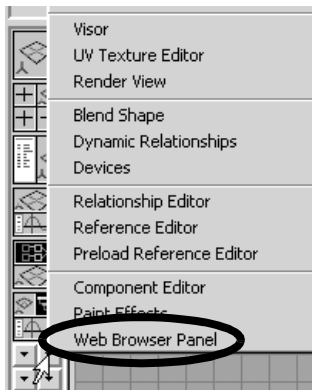

- 2 Type in a URL or MEL command in the entry field.

- Precede URLs with `http://`
- Precede MEL commands with `mel://`

## Maya browser controls

The following controls are available in the Maya browser:

## 2 | General

### > Configuring the Maya browser

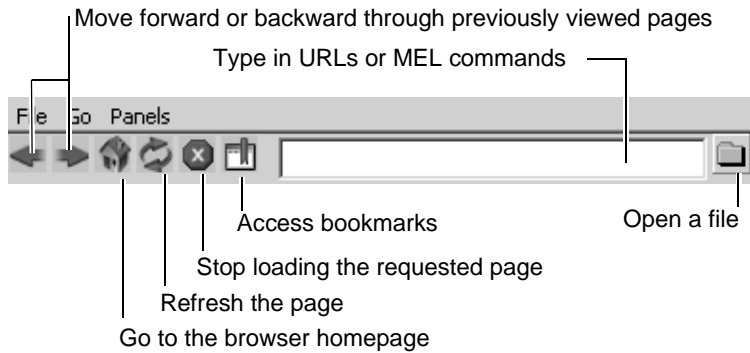

## Configuring the Maya browser

If you are on a LAN, you may need to set up one or more proxies to access external Internet servers. If you don't know the name or port number of your proxy server, check the settings of your current browser, or contact your LAN administrator.

### **To configure the Maya browser for use with a network proxy**

- 1** Select Window > Settings/Preferences > Preferences.  
The Preferences dialog box appears.
- 2** Under Settings, select Web Browser from the Categories list.
- 3** Type in the appropriate settings under Network Configuration. You can choose from Direct Connection, Manual Proxy (which you must specify), or Automatic Proxy.

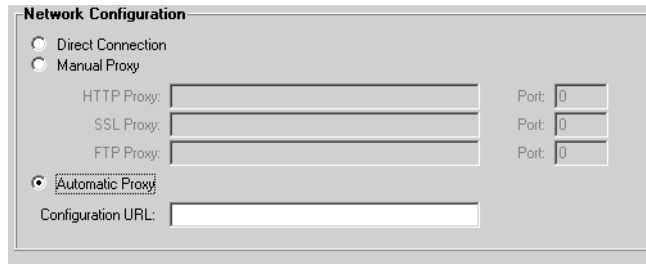

- 4 Click Save.

### **To set whether the Maya help opens in the Maya browser or an external browser**

- 1 Select Window > Settings/Preferences > Preferences.  
The Preferences dialog box appears.
- 2 Select Misc from the Categories list.
- 3 In the Help Browser section, select one of the following:
  - Open Help In Main Maya Window – select this to launch the Maya online help in a panel
  - Open Help Using External Browser – select this to launch the Maya online help in your default Web browser (default)
- 4 Click Save.

### **To set the home page**

- 1 Select Window > Settings/Preferences > Preferences.  
The Preferences dialog box appears.
- 2 Select Settings > Web Browser from the Categories list.
- 3 Type in the URL of the new home page, or click Use Current Page.

## 2 | General

### > Examples of MEL Commands in the browser

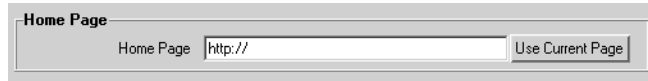

#### 4 Click Save.

## Examples of MEL Commands in the browser

You can communicate with Maya from its Web browser by using MEL commands, which you must precede by `mel://`

The following examples of Maya browser MEL code could be used in a Web page. They produce links that you click in the Maya browser to create and move a cube and a sphere.

```
<a href="mel://nurbsCube/">Create default cube</a><br>
<a href="mel://sphere -radius 3/">Create sphere with radius 3</a><br>
<a href="mel://select nurbsCube1/">Select cube</a><br>
<a href="mel://move -x 5/">Move cube 5 units along X axis</a><br>
<a href="mel://select nurbsSphere1">Select sphere</a><br>
<a href="mel://sphere -edit -radius 8 nurbsSphere1/">Change radius of
sphere to 8</a><br>
```

## Web browser menu items

### File > Open

Lets you load a particular file.

### File > Reload

Reloads a page with its latest version (to ensure that you're not viewing a cached page).

### File > Stop Loading

Stops the loading of a page.

### Go > Back

Goes to previous pages.



#### **Go > Forward**

When you are browsing through previous pages, goes to pages you had viewed subsequently.

#### **Go > Home**

Goes to the browser home page.

## **2 | General**

> Web browser menu items

# 3

# Modeling

## Soft Modification Tool and Deformer

The new Soft Modification Tool lets you push and pull geometry as a sculptor would push and pull on a piece of clay.

By default, the amount of deformation is greatest at the center of the push/pull, and gradually falls off further away from the center. However, you can control the falloff of the deformation to create various types of effects.

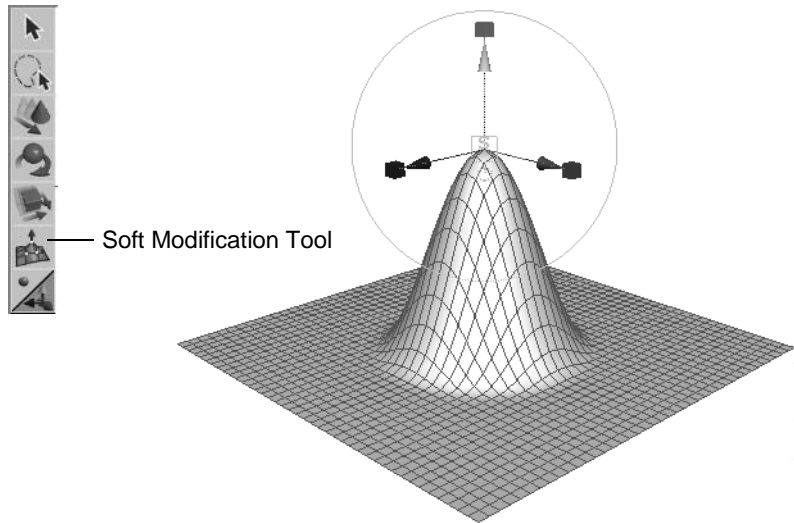

The Soft Modification Tool is located in the Tool Box. The corresponding action is Deform > Soft Modification.

You can use the Soft Modification Tool on NURBS surfaces, polygonal surfaces, subdivision surfaces, curves, particles or any object with components.

## 3 | Modeling

> Deform > Soft Modification > □

### Deform > Soft Modification > □

These are the options in the Soft Modification Options window.

#### Falloff Radius

The radius that the deformation falls off to zero.

#### Falloff Curve

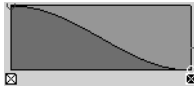

Controls the falloff of the modification.

#### Preserve History

When Preserve History is on, all nodes that the Soft Modification Tool creates are maintained. If you want to animate the effect of the soft modification deformer, you will need to turn on Preserve History to ensure the deformation history is maintained.

When Preserve History is off, the Soft Modification Tool attempts to remove the deformation history and all additional nodes that it creates. If you are using Soft Modification as a modeling tool, and do not want modeling history, you should turn off Preserve History. (In order to generate the correct result, the Soft Modification Tool can only delete deformation history when the underlying shape does not have existing history. If deformer history nodes are still created even when Preserve History is off, try deleting history on the target shape and then try deforming it again. See "Example 2: Modeling without history" on page 67.)

#### Mask Unselected

Controls whether all components are deformed (off) or only selected components are deformed (on).

### Falloff Around Selection

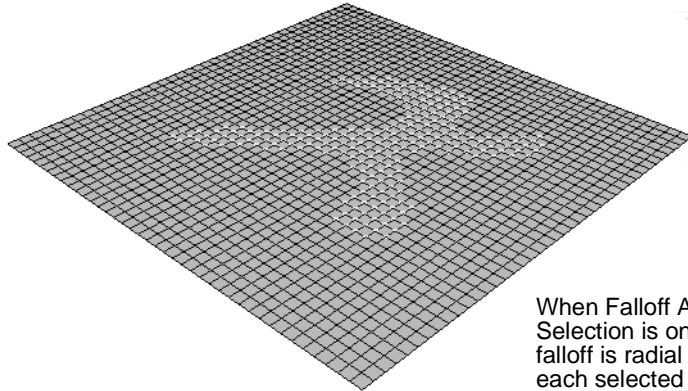

When Falloff Around Selection is on, the falloff is radial around each selected vertex, producing a more natural falloff.

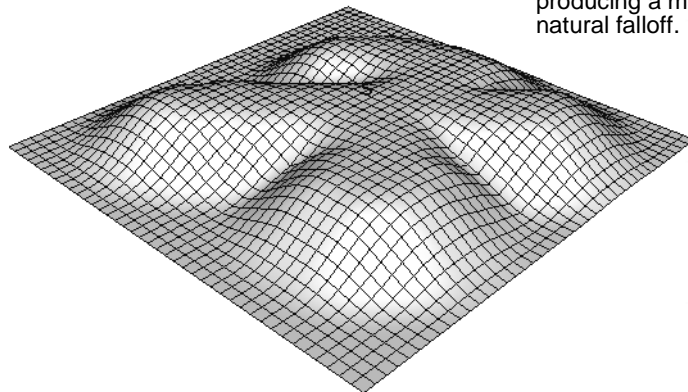

On

The falloff is radial around each selected vertex. This can produce more natural falloff, especially when the selected vertices form an unusual shape.

Off

The falloff is spherical around the center of the selection.

## 3 | Modeling

### > Notes

#### Falloff Based On

The direction(s) in which the deformation falloff curve is applied. By turning off falloff along one or more directions, you can create various effects (for example, ramps, edges).

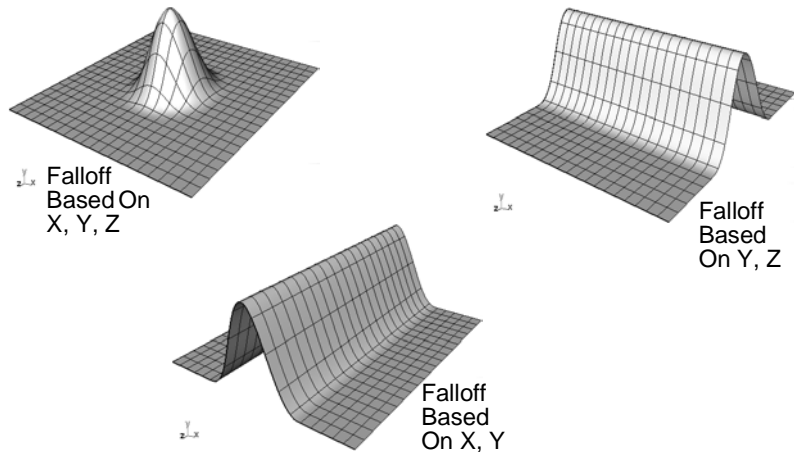

#### Notes

- Soft modification is like a deformer in that it works on clusters.
- You can control the effect of the soft modification by adjusting the Soft Modification Options, the soft modification manipulators, and the softMod node attributes.
- The Soft Modification Tool is similar to the Modify > Transformation Tools > Proportional Modification Tool. However, the Soft Modification Tool provides history and more control (for example, over falloff). The Proportional Modification Tool only works on components. The Soft Modification Tool works on components, objects or multiple objects. The Proportional Modification Tool only works on multiple NURBS surfaces. The Soft Modification Tool works

#### > Deforming objects or components with Soft Modification

on multiple surfaces of any surface type. The Soft Modification Tool can be used with the Deform > Edit Membership Tool.

## Deforming objects or components with Soft Modification

### To deform objects or components with Soft Modification

- 1 Select the objects or components you want to deform.
- 2 Select the Soft Modification Tool in the Tool Box or select Deform > Soft Modification.
- 3 Use the manipulator to create a deformation.
- 4 Adjust the softMod attributes to interactively modify the deformation.

### To deform an object with Soft Modification

- 1 Select the Soft Modification Tool in the Tool Box or select Deform > Soft Modification.
- 2 Click the part of the object you want to modify.
- 3 Use the manipulator to create a deformation.
- 4 Adjust the softMod attributes to interactively modify the deformation.

---

**Tip** When you turn on Window > Settings/Preferences > Preferences > Settings > Selection > Click Drag Select, you can simply choose the Soft Modification Tool, and click-drag on the object to modify it. This lets you quickly perform several modifications on an object. See "Example 2: Modeling without history" on page 67.

---

### 3 | Modeling

> Deforming objects or components with Soft Modification

#### Example 1: Modeling with history

This example shows you how to interactively deform an object using the Soft Modification Tool.

- 1 Select the Soft Modification Tool in the Tool Box.
- 2 Click the part of the surface you want to modify.

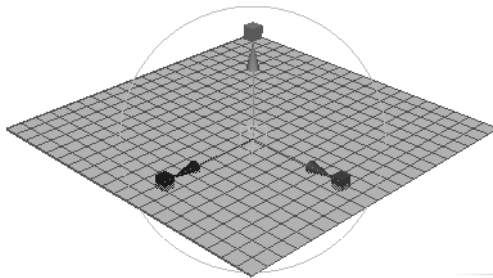

- 3 Move the manipulator to create a deformation.

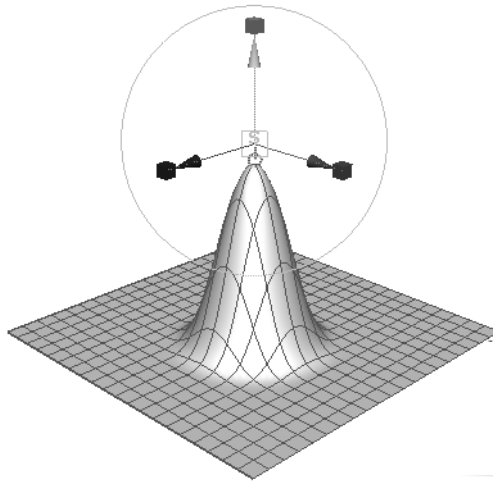

- 4 Click the cycling index to display the falloff manipulator.



### 3 | Modeling

> Deforming objects or components with Soft Modification

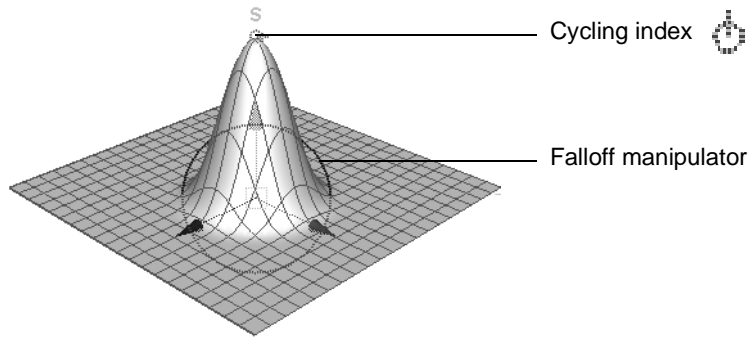

**5** Drag the falloff manipulator circle to adjust the falloff radius.

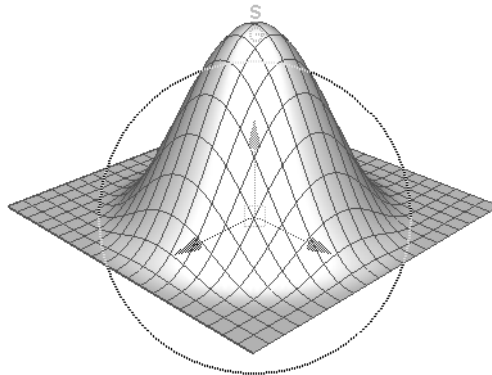

**6** Adjust the softMod node Falloff Curve to interactively adjust the falloff of the deformation.

### 3 | Modeling

> Deforming objects or components with Soft Modification

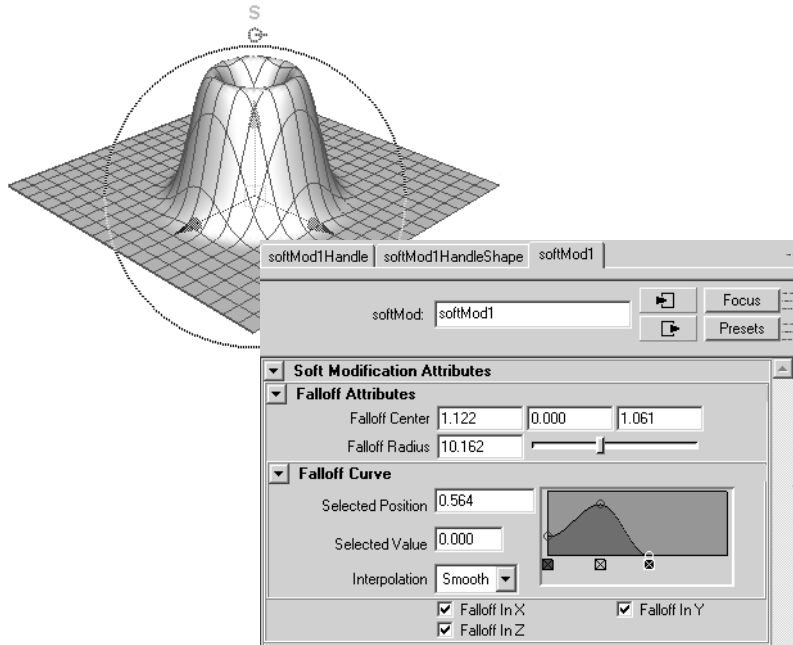

**7** Move the falloff manipulator to re-position the deformation.

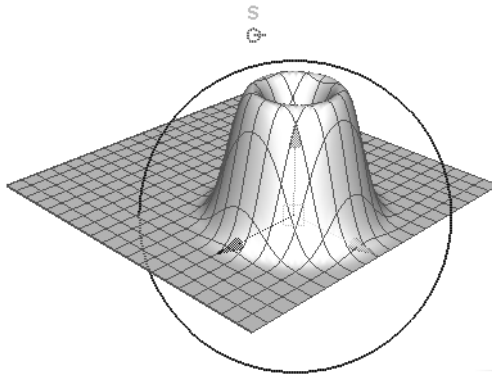

#### Example 2: Modeling without history

This example shows you how to quickly model an object using the Soft Modification Tool to push and pull the surface like a piece of clay without creating deformation history.

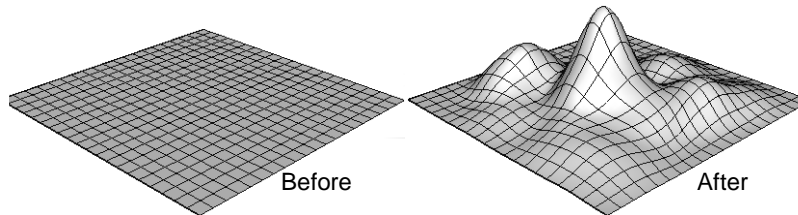

- 1** Select Window > Settings/Preferences > Preferences to open the Preferences window.
- 2** Select Selection, turn on Click Drag Select, and click Save to close the Preferences window.
- 3** Select the object you want to modify, and select Edit > Delete by Type > History to delete history on the object.

By deleting history on the object, and turning off the Preserve History option (see below), the Soft Modification Tool will attempt to remove the deformation history on the object.

- 4** Clear the selection (so the object is no longer selected).

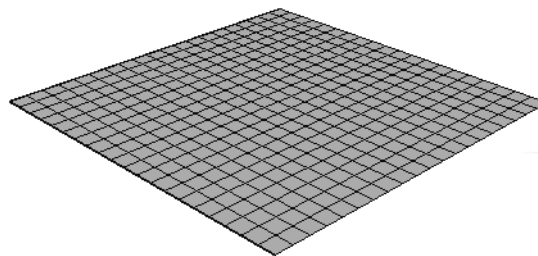

- 5** Select Deform > Soft Modification > , and set the following:
  - turn off Preserve History

### 3 | Modeling

> Deforming objects or components with Soft Modification

- turn off Mask Unselected
- turn off Falloff Around Selection

Then click Soft Modification.

- 6 Click and hold the left mouse button on the part of the object you want to modify, and without releasing the mouse button, drag in the direction you want to deform the object.

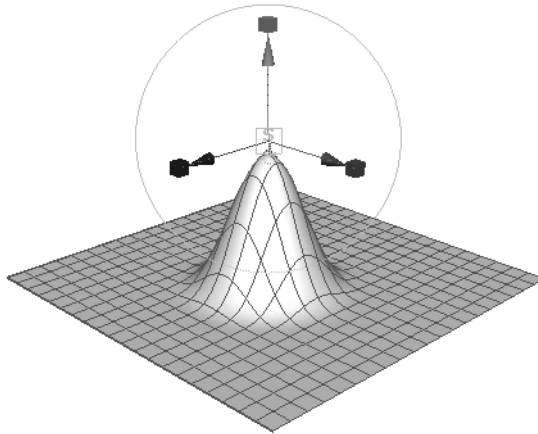

- 7 Continue dragging different parts of the object to create the desired shape.

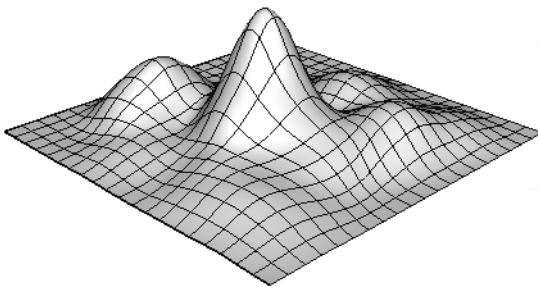

#### Example 3: Moving a character's ear

This example shows you how to move a character's ear so that the skin surrounding the ear adjusts to accommodate the new position of the ear.

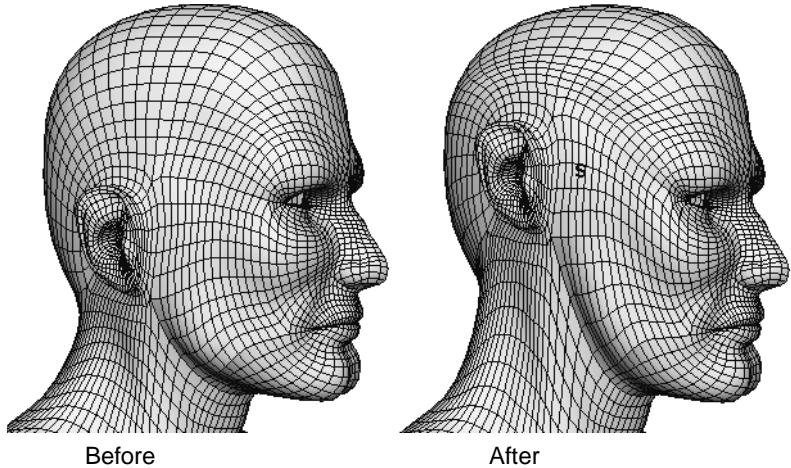

- 1 Select the vertices of the ear and surrounding skin that you want to move. Make sure you select the ear vertices on both sides of the head so the deformation will be symmetrical.  
(The region surrounding the selection will deform so the vertices you move blend naturally into the surrounding area.)

### 3 | Modeling

> Deforming objects or components with Soft Modification

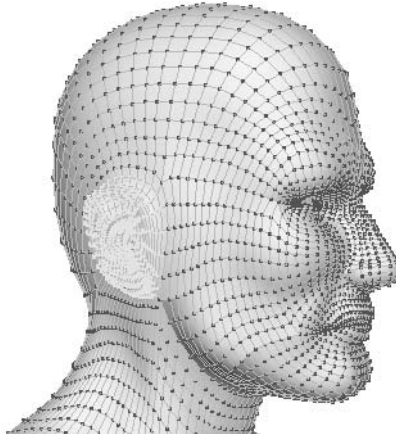

**2** Select Deform > Soft Modification > , and set the following:

- turn on Preserve History
- turn off Mask Unselected
- turn on Falloff Around Selection

Then click Soft Modification.

**3** Use the manipulator to move the ear (for example, up).

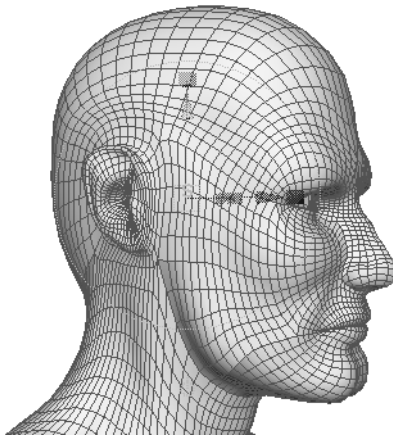

### 3 | Modeling

> Deforming objects or components with Soft Modification

- 4 Adjust the softMod attributes (for example, Falloff Radius, Falloff Curve) to interactively adjust how the new ear position blends into the surrounding skin.

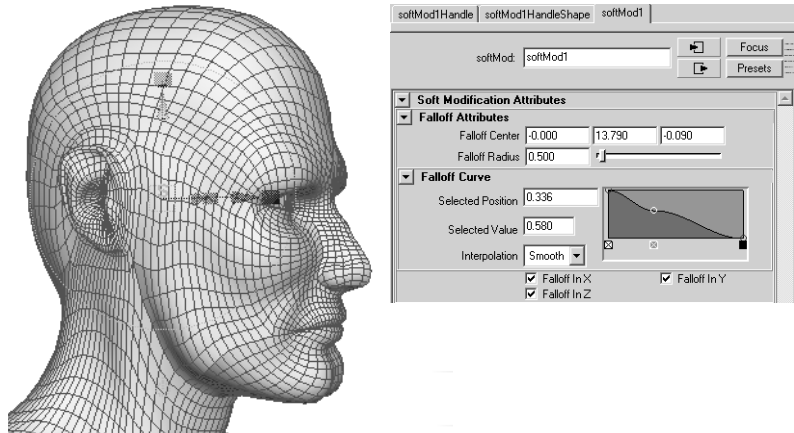

#### Example 4: Symmetrically deforming a character's nose

This example shows you how to symmetrically modify the nose on a character's face using the Soft Modification deformer.

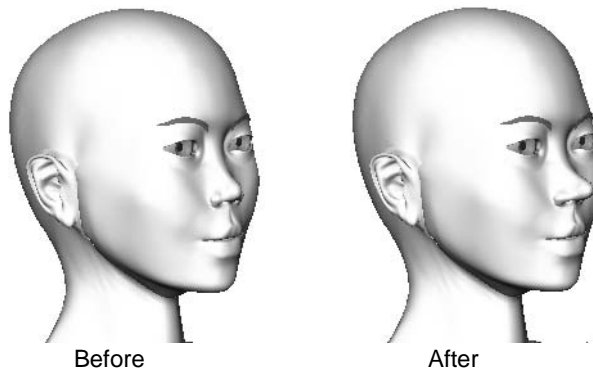

- 1 Select a single vertex in the center of the character's nose.

### 3 | Modeling

> Deforming objects or components with Soft Modification

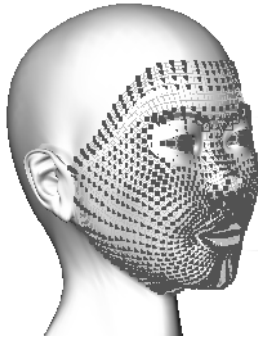

- 2** Select Deform > Soft Modification > , and set the following:
- turn on Preserve History
  - turn off Mask Unselected
  - turn on Falloff Around Selection
- Then click Soft Modification.

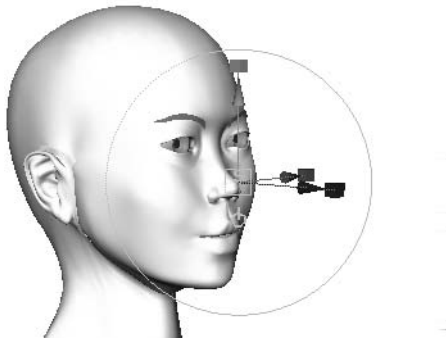

- 3** Use the manipulator to create a deformation.



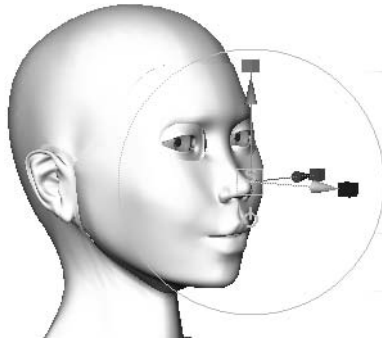

- 4 Adjust the softMod attributes (for example, Falloff Radius, Falloff Curve) to interactively adjust the effect of the deformation (for example, to make the new nose shape blend smoothly into the rest of the face).

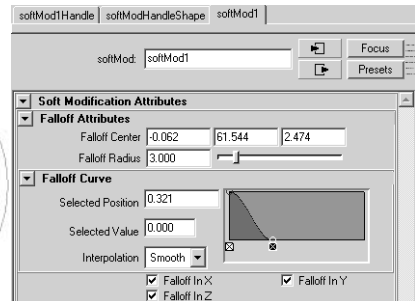
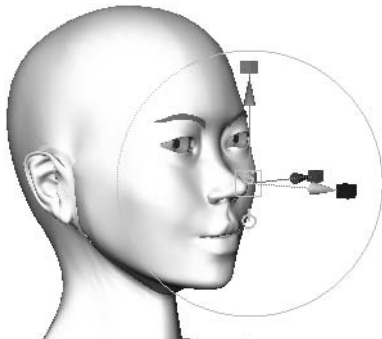

## Polygon Mirror Cut

The new Polygons > Mirror Cut creates a plane of symmetry that mirrors the selected object. You can position the symmetry plane using the manipulator. Changes that you make to the original object are then updated on the mirrored object. This can make

### 3 | Modeling

#### > Polygon Mirror Cut

symmetrical modeling of certain types of objects much easier (for example, creating an environment with streets, creating a skateboard park).

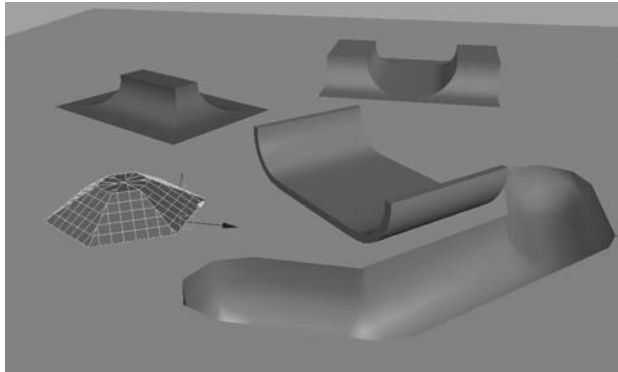

#### To model an object symmetrically with Mirror Cut

- 1 Select a mesh.
- 2 Select Polygons > Mirror Cut.

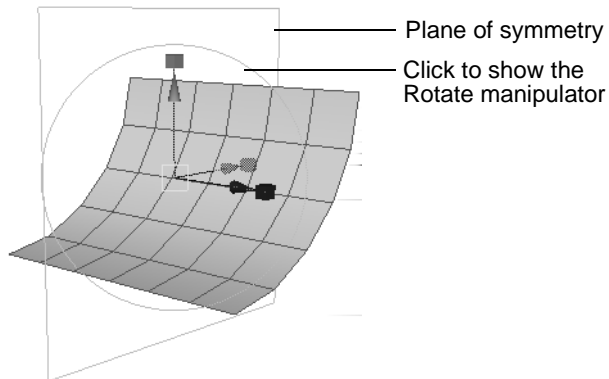

- 3 Use the manipulator to adjust the plane of symmetry.

- Notes
- If you position the plane of symmetry so it is beyond the positive edge of the original object, then both the original object and its mirror image will disappear (except for one face on each). If you want to mirror the object in the direction of its positive edge, then move the symmetry plane so it intersects the original object and rotate the symmetry plane 180 degrees.
  - When you delete history of an object on which you have applied Polygons > Mirror Cut, the plane of symmetry is not deleted. You must manually delete the plane of symmetry.

## Poly Mirror Cut Options

These are the options in the Poly Mirror Cut Options window.

### Cut Along

The pair of axes to mirror the object across: YZ, XZ, or XY.

### Combine Meshes

Combines the original object and the mirrored object into a single mesh. Changes that you then make to the original object are not updated on the mirrored object.

### Merge Vertex Tolerance

Vertices within this distance of each other will be merged. This option is only available when Combine Meshes is on.

## Smooth Proxy

The following improvements have been made to Polygons > Smooth Proxy:

- Performance improvement

## 3 | Modeling

### > Performance improvement

- Mirroring
- Share Transform Node
- Proxy Mesh Renderable
- Hotkeys
- Smooth UVs on non-manifold geometry.

## Performance improvement

Polygons > Smooth Proxy now performs much faster:

- When tweaking the base mesh vertices, Smooth Proxy is at least six times faster than in Maya 5.0. (When Subdivision Method is Linear and the object contains triangles or polygons with more than four edges, then the performance will be the same as in Maya 5.0.)
- For small models, interactive edits are at least 3 times faster than in Maya 5.0. The performance improvement increases with larger models. For example, for a large model with 40k faces, and using 1 level of subdivision, the performance improvement is 18 times faster than in Maya 5.0.
- Playback (when the base mesh vertices have been keyframed) is now faster.

## Mirroring

Polygons > Smooth Proxy has new options that let you create a symmetrical smooth proxy.

### Mirror Behavior

Controls how the smooth mesh and proxy mesh are mirrored and/or located relative to each other.

None	The smooth mesh is created within the proxy mesh.
------	---

Full

The smooth mesh is created within the proxy mesh, and both the proxy mesh and the smooth mesh are mirrored about the Mirror Direction.

Adjustments that you make to one half of the proxy mesh are automatically mirrored onto the other half, making symmetrical modeling much easier.

Half

The smooth mesh is created adjacent to the proxy mesh (based on the Mirror Direction). This allows you to modify the proxy mesh and clearly see the result on the smooth mesh.

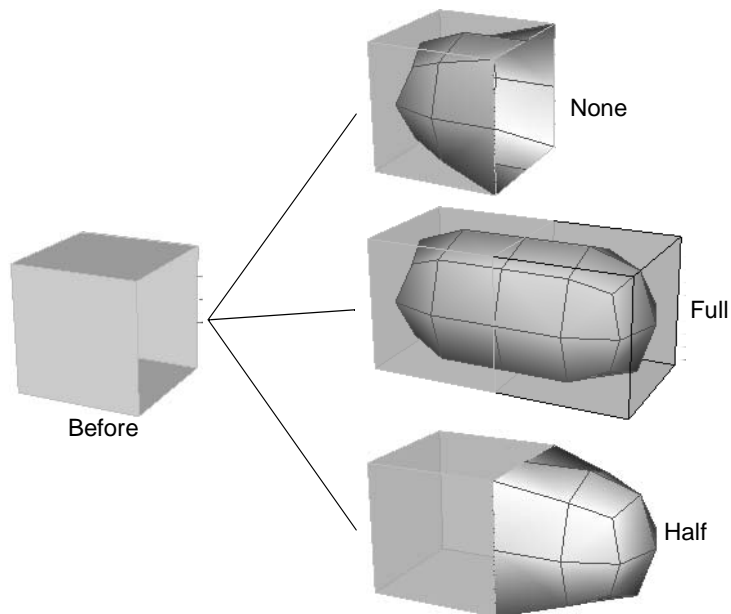

## 3 | Modeling

### > Mirroring

---

**Note** You would usually use mirroring for *modeling* an object, not animating it. Otherwise, the object's animation would be symmetrical.

After you have finished modeling an object with mirroring, use Polygons > Unmirror Smooth Proxy to remove the smooth mesh (see "Unmirror Smooth Proxy" on page 82). Then create a new smooth proxy (with Mirror Behavior set to None) for animating the object.

---

#### Mirror Direction

The direction that the selected mesh will be mirrored.

Smooth Proxy will mirror the proxy mesh at the extent of its bounding box in the Mirror Direction.

#### Merge Vertex Tolerance

When a vertex on the original mesh and its corresponding mirrored vertex are closer than the Merge Vertex Tolerance, then they will be merged into a single vertex.

---

**Note** If you modify the *mirrored* half of the smooth proxy in *object* space mode, dragging a manipulator in one direction will modify the proxy in the *opposite* direction.

If you modify the *mirrored* half of the smooth proxy in *world* space mode, dragging a manipulator in one direction will modify the proxy in the *same* direction.

If you modify the *original* half of the smooth proxy, in *object* space or *world* space mode, dragging a manipulator in one direction will modify the proxy in the *same* direction.

---

### Example

- 1 Select a mesh.

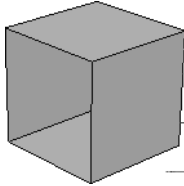

- 2 Select Polygons > Smooth Proxy > , set Mirror Behavior to Full, set the Mirror Direction, and click Smooth. The original mesh is mirrored along the Mirror Direction.

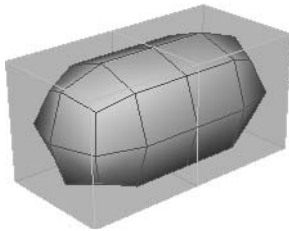

- 3 Modify one half of the smooth proxy (for example, using Edit Polygons > Extrude Face). The modification automatically updates on the opposite half of the smooth proxy.

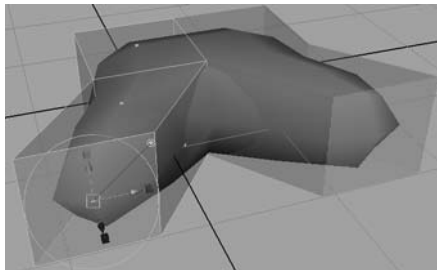

### 3 | Modeling

#### > Share Transform Node

## Share Transform Node

Polygons > Smooth Proxy has a new Share Transform Node option that controls whether the smooth mesh is transformed when you transform the proxy mesh.

For example, you may prefer to move the proxy mesh away from the smooth mesh in order to adjust the proxy mesh and clearly see the effect on the smooth mesh. In this case, turn off Share Transform Node.

Or you may prefer to keep the proxy mesh and smooth mesh together. In this case, turn on Share Transform Node.

### Share Transform Node

- |     |  |
|-----|--|
| On  | If you transform the proxy mesh, the smooth mesh will also be transformed. |
| Off | If you transform the proxy mesh, the smooth mesh will not be transformed.  |

**Tip** When working with Smooth Proxy, you can save the low-res mesh and use it for fast interactive playback. Use Polygons > Smooth Proxy with Share Transform Node turned off. Bind the proxy mesh to a skeleton, and hide the smooth mesh using the hotkey ` (left open quote beside the 1 key). The low-res mesh will provide fast interactive playback. To display the smooth mesh (for example, for rendering), press the ` hotkey again. (Or turn off the Proxy Mesh Renderable option so the proxy mesh is not rendered.)



## Proxy Mesh Renderable

Polygons > Smooth Proxy has a new option that lets you control whether the proxy mesh is rendered or not.

### Proxy Mesh Renderable

Controls whether the proxy mesh is rendered (on) or not (off).

## Hotkeys

Polygons > Smooth Proxy now uses the following hotkeys.

` (left single quote beside the 1 key)	Turns on/off the display of the proxy mesh or the smooth mesh.
Shift + `	Displays both the proxy mesh and the smooth mesh.
Ctrl + `	Polygons > Smooth Proxy
Ctrl + Shift + `	Polygons > Smooth Proxy > <input type="checkbox"/>
Page Up	Increases the denseness of the smooth mesh.
Page Down	Decreases the denseness of the smooth mesh.

Previously, the ` hotkey was used to set keyboard focus to the Command Line.

## 3 | Modeling

### > Unmirror Smooth Proxy

## Unmirror Smooth Proxy

The new Polygons > Unmirror Smooth Proxy removes the smooth mesh created by Polygons > Smooth Proxy (with Mirror Behavior set to Full) and combines the two halves of the proxy mesh (the original mesh and the mirrored mesh) into a single mesh (similar to using Polygons > Mirror Geometry on the original mesh).

Adjustments that you make to one half of the mesh will no longer be automatically mirrored onto the other half.

After you have created a symmetrical model using Polygons > Smooth Proxy (with Mirror Behavior set to Full), use Polygons > Unmirror Smooth Proxy to remove the smooth mesh. Then use Polygons > Smooth Proxy (with Mirror Behavior set to None) to create a smooth mesh that you can animate non-symmetrically.

### Unmirror Direction

The direction that the original proxy mesh will be mirrored. (Set Unmirror Direction to the same setting you used for Mirror Direction with Polygons > Smooth Proxy.)

## Smooth UVs on non-manifold geometry

Polygons > Smooth Proxy can now smooth UVs on non-manifold geometry. Previously, the Polygons > Smooth Proxy operation would fail on non-manifold geometry unless Smooth UVs was turned off.

## Vertex Normal Edit Tool

The new Edit Polygons > Normals > Vertex Normal Edit Tool lets you adjust the user-defined normal of a vertex (or several selected vertices) using a manipulator, for example, in order to make sharp corners appear smoother or to adjust the lighting on a polygonal object. (Previously you had to adjust normals using Edit Polygons > Normals > Set Vertex Normal and entering values numerically.)

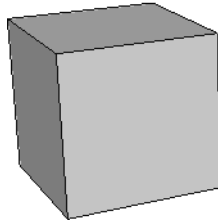

A cube with default vertex normals.

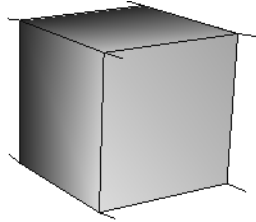

A cube with vertex normals modified to simulate lighting.

## Vertex Normal Manip Settings

These are the options in the Vertex Normal Manip Settings window.

### Rotate Mode

Local	Rotates the vertex normal about the object space axes.
Global	Rotates the vertex normal about the world space XYZ axes.

### Deformable

Allows user-defined vertex normals to be affected by skinning.

On	Vertex normals will be modified by the same weight skinning as the vertex.
Off	Vertex normals will remain in the original object space.

## 3 | Modeling

### > Modify Curve Tools

## Modify Curve Tools

Several new curve modification tools have been added to the Edit Curves > Modify Curves menu. These tools are especially useful for modifying curves that have many CVs. These tools work on selected curves or selected CVs.

**Tip** Because Straighten, Smooth, Bend, and Scale Curvature are actions that you apply to curves, you cannot interactively adjust their effect as you would with a tool. However, you can set the scaling of the tool very low (for example, set Straightness to 0.1) and repeatedly apply the action until the curve has the desired shape.

**Note** These tools are also included in the Hair > Edit Curves menu in Maya Unlimited. For more information on hair, see "Long hair and dynamic curves for Maya Unlimited" on page 21.

## Lock Length

When you select Edit Curves > Modify Curves > Lock Length, the selected curve (or selected CVs) will maintain a constant hull length. If you then modify the curve, for example, by moving a CV, the shape of the curve will adjust so that it maintains a constant hull length (that is, CVs other than the one you move will also move).

When you select Edit Curves > Modify Curves > Lock Length, a Lock Length attribute is added to the curveShape node.

## Notes

- You can use the l (lower-case L) key as a momentary hotkey. Press and hold down the l key to lock the length of the selected curve. Release the l key to unlock the length of the curve.
- Lock Length is useful for modeling purposes. Because modifying a curve with Lock Length turned on behaves similar to a dynamic simulation, animating a curve in this way (with keyframes) may produce unexpected results.
- If you turn on Lock Length, move a CV and then select Undo, only the CV you moved will return to its original position.
- If you turn on Lock Length and modify the curve, the curve's first CV will not move (unless you explicitly move the first CV). For example, if you move the curve's first CV, the curve will respond differently than if you move the curve's last CV.

## Unlock Length

When you select Edit Curves > Modify Curves > Unlock Length, the selected curve (or selected CVs) will no longer maintain a constant hull length. If you then modify the curve, for example, by moving a CV, the curve's hull length will not remain constant (and only the CV you move will actually move).

When you select Edit Curves > Modify Curves > Unlock Length, the curveShape's Lock Length attribute is turned off.

## Straighten

Makes the selected curves (or selected CVs) straighter (in the direction of the curve's first segment). The curve's first CV will maintain its original position.

## Straighten Curves Options

These are the options in the Straighten Curves Options window.

### 3 | Modeling

#### > Straighten

#### Straightness

Determines how much each segment of the selected curves will be straightened. The higher the Straightness, the greater the effect. The effect will be greater on a curve with many CVs than on a curve with few CVs because the Straightness affects each segment.

When Straightness is 0, selected curves will not be straightened at all. When Straightness is 1, selected curves will become entirely straight. When Straightness is 2, selected curves will be flipped so they have the opposite curvature.

#### Preserve Length

The selected curve will remain the same length after straightening. The curve's first CV will maintain its original position, but its last CV will change position. (If you are applying Straighten to selected CVs with Preserve Length on, then some non-selected CVs may also be affected.)

If preserve Length is off, the curve's first and last CVs will both maintain their original positions.

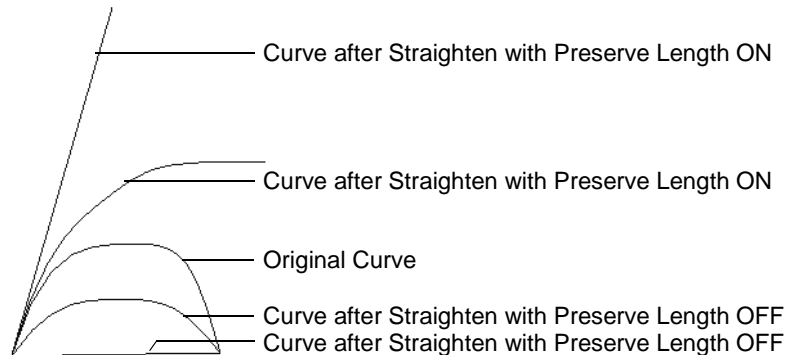

## Smooth

Makes the selected curves (or selected CVs) smoother. The curve's first and last CVs will maintain their original positions.

### Smooth Curves Options

This is the option in the Smooth Curves Options window.

#### Smooth Factor

Determines how much each segment of the selected curves will be smoothed. The higher the Smooth Factor, the greater the effect. The effect will be greater on a curve with many CVs, than on a curve with few CVs, because the Smooth Factor affects each segment.

## Curl

Makes the selected curves (or selected CVs) curly so they resemble a helix. The curve's first CV will maintain its original position.

**Tip** Do not apply Curl to a curve twice. The second Curl will produce poor results because it is trying to curl a curve that is already curly.

### Curl Curves Options

These are the options in the Curl Curves Options window.

#### Curl Amount

Determines how much each segment of the selected curves will be curled. The higher the Curl Amount, the greater the effect. The effect will be greater on a curve with many CVs than on a curve with few CVs because the Curl Amount affects each segment.

## 3 | Modeling

### > Bend

#### Curl Frequency

Determines how many curls the selected curves will be curled into.

#### Bend

Makes the selected curves (or selected CVs) bend in one direction. The curve's first CV will maintain its original position.

#### Bend Curves Options

These are the options in the Bend Curves Options window.

##### Bend Amount

Determines how much each segment of the selected curves will be bent. The higher the Bend Amount, the more the curve will be bent. A curve with many CVs will be bent more than a curve with few CVs because the Bend Amount affects each segment.

##### Twist

Controls the direction in which the selected curves will be bent.

#### Scale Curvature

Makes the selected curves (or selected CVs) straighter or exaggerates their existing curvature, depending upon the Scale Factor and Max Curvature values.

#### Scale Curvature Options

These are the options in the Scale Curvature Options window.

##### Scale Factor

Determines how much each segment of the selected curves will be straightened or have their existing curvature exaggerated. The higher the Scale Factor, the greater the



effect. The effect will be greater on a curve with many CVs than on a curve with few CVs because the Scale Factor affects each segment.

If Scale Factor is less than 1, the selected curves will become straighter.

If Scale Factor is greater than 1, the selected curves will have their existing curvature exaggerated (by exaggerating the curvature of each segment in the same direction as its existing curvature).

### Max Curvature

Controls the maximum angle allowed between adjacent segments.

If Max Curvature is 1, then the maximum angle allowed between adjacent segments is 180 degrees. If Max Curvature is 0.5, then the maximum angle allowed between adjacent segments is 90 degrees.

**Note** If the selected curve already has adjacent segments with an angle greater than that allowed by the Max Curvature value, and you apply Scale Curvature with a Scale Factor greater than 1 (that is, to exaggerate the curvature of the curve), the curve may actually become straighter. This is because the Max Curvature value is reducing the angle between adjacent segments.

## Polygon Smooth

Polygons > Smooth can now smooth UVs on non-manifold geometry. Previously, the Polygons > Smooth operation would fail on non-manifold geometry unless Smooth UVs was turned off.

### 3 | Modeling

#### > Subdivision Surface Polygon Proxy Mode

## Subdivision Surface Polygon Proxy Mode

The performance of Subdiv Surfaces > Polygon Proxy Mode has improved. When editing native subdiv surfaces by pulling CVs on the proxy cage, performance has been significantly improved. (This performance improvement does not apply when making topology changes to the poly cage.)

The performance is typically 8 times faster (than in Maya 5.0) when moving a small number of vertices, and 2.5 times faster when moving all vertices.

**Tip** If you find it difficult to work with Subdiv Surfaces > Polygon Proxy Mode because the subdivision surface and the polygon proxy are the same color (for example, light blue), set your preferences so subdivision surfaces and polygon surfaces are displayed in different colors. Select Window > Settings/Preferences > Colors and set the Active/Inactive colors for Polygon Surfaces and Subdivision Surfaces.

## Polygon Bevel

Edit Polygons > Bevel has improved.

- Previously, you could potentially create inside-out bevels or bad geometry. This is now much less likely.
- Previously, Polygon Bevel may have inserted extra unwanted edges. This has now been fixed.
- Roundness can now be negative to create inward bevels.
- Polygon Bevel now works in worldspace by default.
- Polygon Bevel now preserves UVs on unbeveled faces.

- Polygon Bevel no longer triangulates faces with holes before beveling.
- When Segments is greater than 1, the profile of the bevel is now circular (previously it was not exactly circular) and the faces are now equally spaced.
- The Polygon Bevel Options window and the polyBevel node contain new options (see below).

**Tip** You can use Edit Polygons > Bevel on a smooth proxy object to control the shape of the smooth proxy at a corner.

## Polygon Bevel Options

These are the options in the Polygon Bevel Options window.

### Offset Type

Fractional	The bevel will not be greater than the shortest edge (to prevent inside-out bevels).
Absolute	Polygon Bevel behaves the same as it did in Maya 5.0.

### Offset Space

Determines whether a bevel applied to a scaled object will also be scaled.

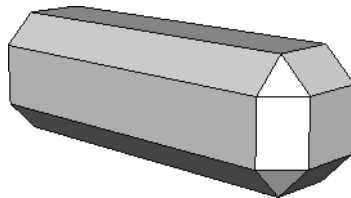

World

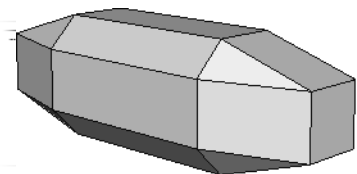

Local

### 3 | Modeling

#### > Polygon Bevel Options

World	If you bevel a scaled object, the offset will ignore the scaling. This is now the default setting.
Local	Polygon Bevel behaves the same as it did in Maya 5.0. If you bevel a scaled object, the offset is also scaled.

#### Offset Distance

Controls the distance between the original edge and the center of the offset face.

When Offset Type is Absolute, Offset Distance is the distance between the original edge and the offset face measured in the scene's linear unit. This is like the radius of the bevel. A large Offset Distance can produce inside-out bevels.

When Offset Type is Fractional, Offset Distance is a value from 0 to 1 that controls the distance between the original edge and the center of the offset face. When Offset Distance is 1, the distance will be the maximum possible that will not produce an inside-out bevel. An Offset Distance greater than 1 will produce inside-out bevels.

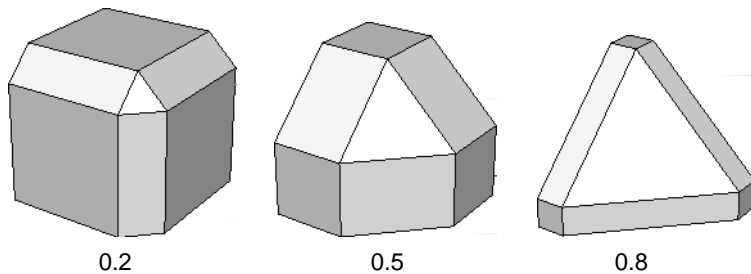

## polyBevel node

### Angle Tolerance

Polygon Bevel uses this angle to decide whether it needs to insert extra edges. If your model still has unwanted edges, try increasing this value to remove them.

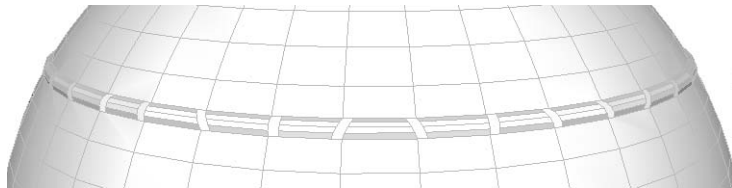

If your model has unwanted edges...

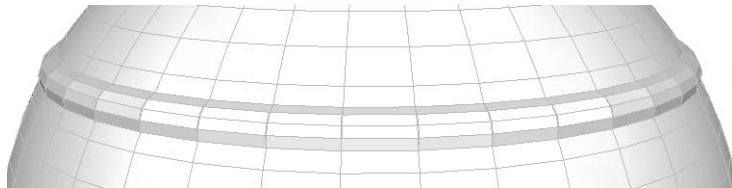

...try increasing Angle Tolerance

## Create Meshes Single Sided

The new menu item Polygons > Tool Options > Create Meshes Single Sided controls whether new polygonal meshes are created single-sided or double-sided.

When this is turned on, new polygonal meshes (for example, created by the polygon primitive tools or by polygonal operations) automatically have their Render Stats > Double Sided attribute turned off.

## 3 | Modeling

### > UV Texture Editor

## UV Texture Editor

Several improvements have been made to the UV Texture Editor.

### Pixel snap to center of pixel

Image > Pixel Snap now lets you snap to the corner or center of a pixel. Previously, it would only let you snap to pixel corners.

To control whether snapping is to pixel corners or centers, display the Move Tool options, (make sure focus is on the UV Texture Editor) and set Placement to Snap Corner or Snap Center.

### Display improvements

The alternative display option added to the UV Texture Editor in Maya 5.0.1 has been improved to provide more control over the resolution of baked textures. Several display problems have also been fixed.

Whenever possible, baked textures make use of repeating regions to make best use of texture resolution.

Image > Editor Image > Display has been renamed to Image > UV Texture Editor Baking. The Editor Image button has been renamed to Bake editor texture on/off.

Image > Editor Image > Bake has been removed. The Bake button has been renamed to Force editor texture rebake. Now, when you select Image > UV Texture Editor Baking, the texture is automatically baked and stored in memory. (Previously you had to manually bake the texture, which was then saved to disk, in some cases taking several minutes.) You can control image quality by selecting Image > UV Texture Editor Baking .

### File format support

Maya now supports the following file formats:

- Adobe Photoshop (see “Adobe Photoshop file support” on page 219)
- PNG (see “Image file support” on page 365)
- DDS (see “Image file support” on page 365).

## Split Polygon Tool

When using the Edit Polygons > Split Polygon Tool, you can now click the right mouse button to finish the split. This lets you very quickly split successive polygons. Previously, you had to press y to finish the split.

## Convert Polygons to Subdiv, NURBS to Subdiv

Modify > Convert > Polygons to Subdiv and Modify > Convert > NURBS to Subdiv now use the following hotkeys.

<p>` (left single quote beside the 1 key)</p>	<p>Turns on/off the display of the original surface or the converted subdiv surface.</p>
<p>Shift + `</p>	<p>Displays both the original surface and the converted subdiv surface.</p>
<p>Alt + `</p>	<p>If a NURBS surface is selected: Modify &gt; Convert &gt; NURBS to Subdiv                      If a polygonal surface is selected: Modify &gt; Convert &gt; Polygons to Subdiv</p>
<p>Alt + Shift + `</p>	<p>If a NURBS surface is selected: Modify &gt; Convert &gt; NURBS to Subdiv &gt; <input type="checkbox"/>                      If a polygonal surface is selected: Modify &gt; Convert &gt; Polygons to Subdiv &gt; <input type="checkbox"/></p>

### 3 | Modeling

#### > Heads Up Display

Page Up	Increases the Display Level of the subdiv surface (when in subdivision surface standard mode).
Page Down	Decreases the Display Level of the subdiv surface (when in subdivision surface standard mode).

## Heads Up Display

Display > Heads Up Display > Poly Count now displays the number of triangles.

<b>Verts:</b>	3542	3542	0
<b>Edges:</b>	7140	7140	0
<b>Faces:</b>	3600	3600	0
<b>Tris:</b>	7080	7080	0
<b>UVs:</b>	3604	3604	0

Number of triangles

## Curve/CV Selection

Several new actions let you easily adjust the selection of CVs for the active curve:

- Edit Curves > Selection > Select Curve CVs
- Edit Curves > Selection > Select First CV on Curve
- Edit Curves > Selection > Select Last CV on Curve
- Edit Curves > Selection > Cluster Curve (creates a cluster for each CV on the curve, for example, when building a character's back with spline IK)

You can also access these actions for the active curve from the marking menu Ctrl + the right mouse button.



## Convert NURBS to Polygons as Single Mesh

Modify > Convert > NURBS to Polygons now has an Attach Multiple Output Meshes option that produces a single mesh (even if the original NURBS object consists of separate surfaces). (The new Merge Tolerance option controls how close vertices must be in order to be merged into a single mesh.)

For example, if you convert a NURBS cube (which consists of six separate faces), the resulting polygon cube will consist of a single mesh. Previously, the polygon cube would consist of six separate meshes.

This tool also works on trimmed surfaces.

## Scale/Rotate Components About Object Pivot Point

The Scale Tool and Rotate Tool now have a Component Use Object Pivot option that lets you scale and rotate object components about the object's pivot point.

Component Use Object Pivot is also included in the marking menus for the Scale Tool (r + the left mouse button) and the *Rotate tool* (e + the left mouse button).

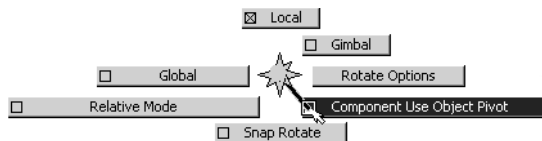

## Merge Vertices

Edit Polygons > Merge Vertices is now faster in most cases.

## 3 | Modeling

### > Rebuild Curve

## Rebuild Curve

Edit Curves > Rebuild Curve now lets you set Number of Spans greater than 100.

## Rebuild Surfaces

Edit NURBS > Rebuild Surfaces now has an enhanced version of the Rebuild Type named Match Knots that lets you set the new Rebuild Method option to Classic or Match.

Setting Rebuild Method to Match can produce better quality surfaces, especially if the rebuild or reference surface is periodic or if either surface does not have multiple knots at the ends.

Set Rebuild Method to Classic to maintain compatibility with Maya 5.0 files.

## Sculpt Surfaces/Polygons Tools

The following tools now use the new Artisan architecture, providing a common, streamlined options interface:

- Edit Polygons > Sculpt Polygons Tool
- Edit NURBS > Sculpt Surfaces Tool (This tool also now respects Global Stitch.)

## Freeze Transformations (makeIdentity)

Modify > Freeze Transformations has two new options (Normals, Only for non-rigid deformations) and the `makeIdentity` command has a new flag (-normal). These let you use Modify > Freeze Transformations on an object without modifying the object's vertex normals as follows:

- Vertex normals that have been modified by Edit Polygons > Normals > Set Vertex Normal (or the `polyNormalPerVertex` command) will now remain correct after using Modify > Freeze Transformations (or performing the `makeIdentity` command). Previously, using Freeze Transformations or `makeIdentity` would cause modified vertex normals to retain their object space values, which would be incorrect for the new transform and object space positions of the components.
- Vertex normals that have been modified as a result of a non-proportional scale will now remain correct after using Modify > Freeze Transformations (or performing the `makeIdentity` command).

### -normal

The `makeIdentity` command now has a `-normal (-n)` flag. If this flag is set to 1, the normals on polygonal objects will be frozen. This flag is valid only when the `-apply` flag is on. If this flag is set to 2, the normals on polygonal objects will be frozen only if it's a non-rigid transformation matrix (that is, a transformation that does not contain shear, skew or non-proportional scaling). The default behavior is not to freeze normals.

## Freeze Transformation Options

Modify > Freeze Transformations has two new options.

### Normals

The normals on polygonal objects will be frozen.

## 3 | Modeling

### > Persistence of Backface Culling and Color Per Vertex Display Settings

**Note** You only need to turn on Normals if you are applying Modify > Freeze Transformation to an object that has been sheared, skewed or non-proportionally scaled. Turning on Normals will bake the normals so they will not update if you make subsequent tweaks to the object's shape.

#### Only for non-rigid deformations

The normals on polygonal objects will be frozen only if it's a non-rigid transformation matrix (that is, a transformation that does not contain shear, skew or non-proportional scaling).

This option is only available when Normals is on.

## Persistence of Backface Culling and Color Per Vertex Display Settings

Backface culling and color per vertex display settings for each mesh are now maintained when a scene is saved. Previously, these settings were not saved with the scene.

### polyNormalPerVertex

The following improvements have been made to the `polyNormalPerVertex` command:

- The `polyNormalPerVertex` command now has an `-allLocked` (`-al`) flag that queries if all normals on the selected vertices are locked (frozen) or not. See "Freeze Transformations (makeIdentity)" on page 98.
- The `polyNormalPerVertex` command now has a `-deformable` (`-def`) flag that allows user-defined vertex normals to be affected by skinning and other deformers.

- Previously, using the `polyNormalPerVertex` command with the `-q` and `-fn` flags would not return a result. This now queries if the normals on the selected vertices are locked or not.

## Annotation Node

The `annotationShape` node now contains a `Display Arrow` attribute that lets you display or hide the annotation line and arrow.

### **3 | Modeling**

> Annotation Node

# 4 Animation

## Redesigned Trax Editor

### Improved Trax Editor

In Maya 6, the Trax Editor and non-linear animation workflow have been redesigned to address many issues.

When working with non-linear animation in Trax, you no longer have to manipulate clip values from the Channel Box, select characters from the Current Character Set drop-down list, or navigate your track hierarchy using the Trax Outliner.

You can now select and control characters and their clips, and navigate their hierarchies, all in the track view area of Trax. Also, you can now drag-and-drop animation clips between mapped characters. See "Character > Character Mapper" on page 138 and "How do I map one character to another?" on page 134.

The following is a list of some of the new features in Trax:

- Organize and control all clips for each character in one step
- Lock, mute, and solo tracks
- Cycle, hold, trim, and scale clips using new clip interaction functionality
- Key into clips
- Create clips from animations that have expressions or constraints
- More intuitive display of animation blends
- Import and playback multiple audio clips

## 4 | Animation

> Related topics

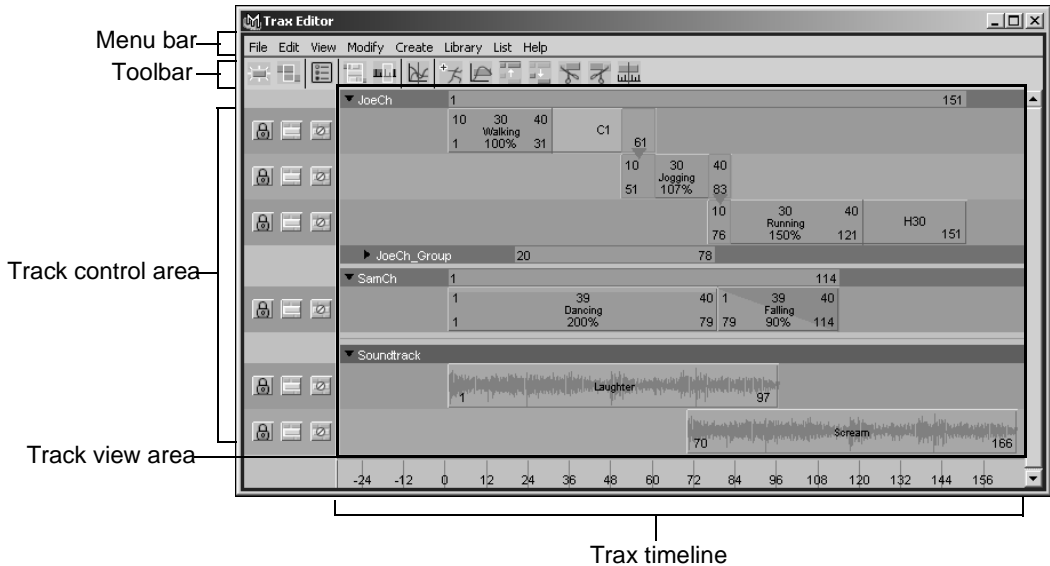

### Related topics

- ❖ “New Trax Editor menu bar items” on page 110
- ❖ “New Trax Editor toolbar buttons” on page 114
- ❖ “New Trax Editor track control area” on page 116
- ❖ “Revised Trax Editor track view area” on page 118

### How do I use the new Trax Editor?

#### To load characters into Trax

- 1 Select the character you want to load from the scene view or from the Current Character Set drop-down list beside the Time Slider.
- 2 Do one of the following:



## 4 | Animation

> How do I use the new Trax Editor?

- In the Trax toolbar, click the Load/Add Character button.
- In the Trax menu bar, select List > Load Selected Characters. See "Load Selected Characters" on page 114.

The character appears in the track view area.

**Note** When List > Auto Load Selected Characters is *on*, all selected characters are automatically loaded into Trax. See "Autoload Selected Characters" on page 114.

### To highlight a character, group, or subcharacter in Trax

Select any clip that is under the character, group, or subcharacter you want to select.

**Note** When a character is highlighted in Trax, its summary is outlined in orange.

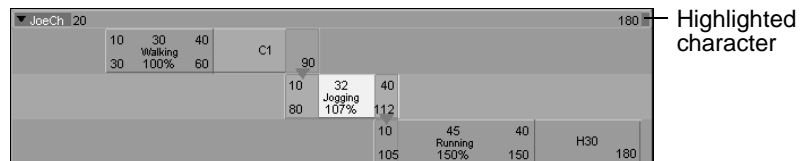

### To add a track to a character, group, or subcharacter

- 1 Select a clip in your character, subcharacter, or group.
- 2 Do one of the following:
  - Drag the clip upwards or downwards.

## 4 | Animation

> How do I use the new Trax Editor?

A black line appears above or below the selected clip's track. This line indicates that Maya will insert a single track above or below the selected clip's track when you release the mouse button.

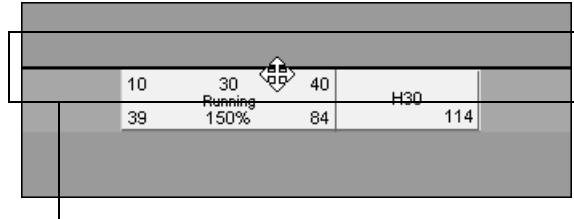

Black line indicates where Maya will insert the track

- Right-click a track, and from the menu that appears select one of the following options: Insert Track Above or Insert Track Below. See "Context-sensitive menus" on page 130. These options insert a track above or below the selected clip's track.

### To remove a track from a character, group, or subcharacter

- Right-click the track you want to remove, and select *Remove Track* from the menu that appears. The track you clicked and all its clips are deleted from its character, group, or subcharacter.

### To remove all the empty tracks from a character

- 1 Highlight the character from which you want to remove all its empty tracks. See "To highlight a character, group, or subcharacter in Trax" on page 105.
- 2 In the Trax menu bar, select *Modify > Remove Empty Tracks*.

All the empty tracks are deleted from the highlighted character.

### **To remove all the empty tracks from all the characters in Trax**

- 1 Make sure that there are no characters highlighted in Trax.
- 2 In the Trax Editor, select **Modify > Remove Empty Tracks**.  
All the empty tracks are deleted from all the characters in Trax.

### **To create a clip**

- 1 Select a character from the scene view or from the Current Character Set drop-down list beside the Time Slider.
- 2 In the Trax toolbar, click the Create Clip  button.  
A clip is created for the current character's animation.

### **To create a constraint or expression clip**

- 1 Select a character from the scene view or from the Current Character Set drop-down list that is constrained or is animated by an expression.
- 2 In the Trax menu bar, select either **Create > Constraint Clip** or **Create > Expression Clip**.  
If the character has any constraint channels, then a constraint clip is created for those channels.  
If the character has any expression channels, then an expression clip is created for those channels.

### **To copy and paste a clip within a character or between characters**

- 1 Select the clip you want to copy.
- 2 Do one of the following:
  - In the Trax menu bar, select **Edit > Copy**.

## 4 | Animation

> How do I use the new Trax Editor?

- Right-click the selected clip and select Copy Clip from the context-sensitive menu that appears.
- Press Ctrl+c.

The selected clip is copied to your system's virtual clipboard.

**3** Right-click the track where you want to paste the copied clip.

**4** Select Paste Clip from the menu that appears.

The copied clip is pasted to the specified character and track.

---

Note Only copy and paste clips between characters if they have been mapped. See "What is character mapping?" on page 134.

---

### To create a group

**1** Select a clip and Shift-click to select additional clips.

**2** Do one of the following:

- In the Trax toolbar, click the Group button.
- In the Trax menu bar, select Edit > Group.

A new group containing the clips you selected appears under their respective character.

### To create an audio clip

For more information, see "Soundtrack" on page 120.

Do one of the following:

- In the Trax Editor, select File > Import Audio.

The Import File browser window appears.

- Browse for the .wav or .aiff file you want to place in Trax.
- Select the desired audio file and click Import.

The selected audio file appears as an audio clip in the Soundtrack.

- Import (Maya main menu bar > File > Import) or drag the desired audio file from your desktop to the Time Slider.

The audio file automatically appears as a waveform in the Time Slider and as an audio clip under the Soundtrack in Trax.

#### **To hear audio clips present in Trax**

- 1 Right-click the Time Slider.

A pop-up menu appears.

- 2 Select Sounds > Use Trax Sounds.

The audio clips in Trax now play during animation playback.

#### **To scale or move groups of clips**

- 1 Select a clip and Shift-click to select additional clips.

The clip manipulator appears.

- 2 Do one of the following:

- Drag the clip manipulator's scale handles (arrows) to scale all the clips in your selection.
- Drag the clip manipulator's translate handle (circle) to move all the clips in your selection.

---

**Note** You can only move clips horizontally (side to side) using the manipulator's translate handle.

---

For more information, see "Scale and move multiple clips at a time" on page 127.

## 4 | Animation

> New Trax Editor menu bar items

### To view clips in the Outliner

- 1 Select Window > Outliner.
- 2 In the Outliner, turn off Display > DAG Objects Only.
- 3 Turn on Show > Objects > Clips.

All the source and regular clips in your scene are now listed in the Outliner.

**Tip** You can create instances of clips by dragging them from the Outliner onto a character in the track view area of the Trax Editor.

### To set the Time Slider's playback range to the range of the clips in Trax

- 1 In the Trax toolbar, click the Frame All  button.  
All the animation and audio clips in Trax are now visible in the track view area.
- 2 Right-click the Time Slider.  
A pop-up menu appears.
- 3 Select Set Range to > Enable Clips.  
The Time Slider's playback range is now the same as the range of clips in Trax.

## New Trax Editor menu bar items

For information on all the Trax menu bar menus and options, see Trax menu bar in the Nonlinear Animation chapter of the Animation guide.

**File >****Character Mapper**

Launches the new Character Mapper window. See "Character > Character Mapper" on page 138.

**Edit >****Trim Before**

See "Trim clip before current time" on page 116.

**Trim After**

See "Trim clip after current time" on page 116.

**Duplicate**

In Maya 6, Instance and Duplicate have been combined under the same Trax menu item. When you duplicate a clip, a new track is generated and the copy of the clip is added to this track.

**Duplicate****Input****Connections**

When on, creates a copy of the selected clip whose duplicate animation is independent of the original clip's source animation. This means you can edit the animation on this new clip and it won't affect the animation on your original clip—it will only affect the duplicate. This acts like Edit > Duplicate in Maya 5.0.

When off, creates a copy of the selected clip whose duplicate animation is dependent on the original clip's source animation. This means any modifications made to the

## 4 | Animation

> Edit >

original clip's animation are propagated to the duplicate clip. This acts like Edit > Instance in Maya 5.0.

Duplicate Input Connections is off by default.

Put Copy in  
Visor Only

Places the duplicate clip in the Visor only.

Put Copy in Visor Only is available only when Duplicate Input Connections is on.

---

**Note** When you place clips in the Visor, you can then view and access them from the Outliner. See "To view clips in the Outliner" on page 110.

---

Put Copy in  
Trax Editor  
and Visor

Places the duplicate clip in both the Trax Editor and the Visor.

Put Copy in Trax Editor and Visor is available only when Duplicate Input Connections is on.

Duplicate  
Time Warp  
Curve

When on, an independent copy of the selected clip's time warp curve is created for the duplicate clip. This is useful, for example, when you want a group of characters to all have the same run cycle animations, but you want each of the characters to run at different speeds.



### Instance Time Warp Curve

When on, a dependent copy of the selected clip's time warp curve is created for the duplicate clip. Any changes you make to the original clip's time warp curve are propagated to the duplicate time warp curve.

Instance Time Warp Curve is on by default.

### No Time Warp Curve

When on, the selected clip's time warp curve is not copied to the duplicate clip.

### Group

See "Group" on page 115.

### Ungroup

See "Ungroup" on page 113.

## View >

### Frame Playback Range

Frames the current playback range in the Trax view area.

### Center Current Time

Centers the Trax view area on the current time.

---

**Note** These new View menu items are also available in the Graph Editor and Dope Sheet.

---

## 4 | Animation

> List >

### List >

#### Autoload Selected Characters

When on, any characters you select in either the scene view or the Time Slider's Current Character drop-down list are automatically loaded into Trax. When you cancel your selection, all characters are automatically removed from Trax.

#### Load Selected Characters

Loads all selected characters into Trax. If you use Load Selected Characters, canceling your selection does not remove the characters from Trax.

Only available when Autoload Selected Characters is off.

#### Add Selected Characters

Loads the selected characters into Trax. Use this to add characters to Trax when you have already loaded a number of characters using Load Selected Characters.

Only available when Autoload Selected Characters is off.

## New Trax Editor toolbar buttons

The new toolbar buttons in Trax let you easily access the most commonly used functions.



**Create Clip**

Creates a clip with the keyframe animation of the current character.



**Create Blend**

Creates a blend between two, selected clips. See "Blends" on page 128.

## 4 | Animation

### > New Trax Editor toolbar buttons



#### Get Clips

Launches the Visor. For more information, see *Visor* in the Basics guide.



#### Frame All

Makes all clips in Trax visible in the track view area. This button can also be found in the Graph Editor and Dope Sheet toolbars.



#### Frame Playback Range

Frames all the track view area contents within the Time Slider's current playback range. This button can also be found in the Graph Editor and Dope Sheet toolbars.



#### Graph Anim Curves

Displays the current clip's animation curves in the Graph Editor. See *Graph Editor graph view* in the Animation guide.



#### Load Selected Characters

Loads the character selected in the scene view into Trax.



#### Graph Weight Curves

Displays the selected clip's weight curve in the Graph Editor.



#### Group

Creates a group of clips under the current character and places the selected clips in tracks under that group. See "Groups" on page 119.



#### Ungroup

Removes the selected group from its character and places the group's tracks directly under its character or parent group.

## 4 | Animation

### > New Trax Editor track control area



**Trim clip before current time**

Removes the segment of the selected clip that comes *before* the Trax current time indicator's position.



**Trim clip after current time**

Removes the segment of the selected clip that comes *after* the Trax current time indicator's position.



**Key into clip**

Sets a key on all the curves in the selected clip at the current position of the Trax current time indicator. See "Key into clips" on page 133.

## New Trax Editor track control area

The new track control area lets you lock, solo, or mute all the animation clips in a track.



**Lock**

The Lock button freezes the current animation track. When a track is locked, you can not edit its clips, but its animation is present during playback.

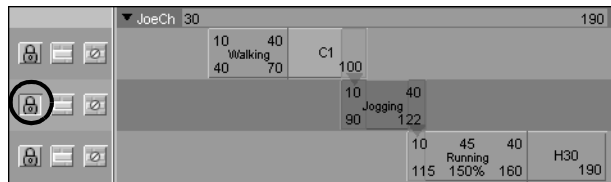

## 4 | Animation

### > New Trax Editor track control area



**Solo** The Solo button isolates the clips on the current track so that they are the only animation sequences that are played during playback for the character. Soloing is useful when you want to isolate and review a specific animation sequence for a character. You can solo single or multiple tracks at a time.

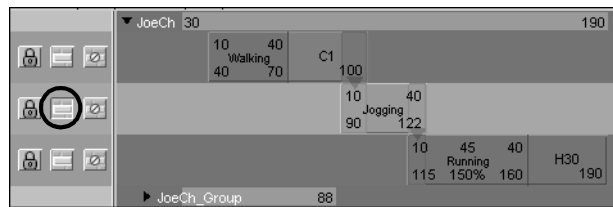

**Mute** The Mute button mutes all the clips on the current track. Muting suppresses or hides the animation on a track without removing it from the Trax Editor. Muting is useful when you want to suppress a specific animation sequence for a character during playback. See *“Muting animation”* in the Animation guide.

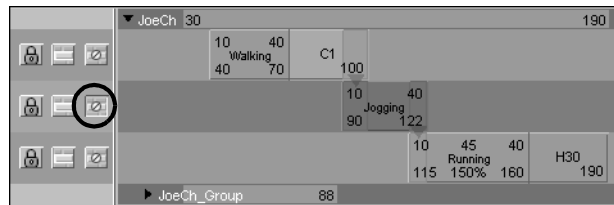

## 4 | Animation

### > Revised Trax Editor track view area

**Note** In addition to tracks, you can also enable and disable a single clip. To enable or disable a clip, right-click the clip and select **Modify > Enable/Disable** from the menu that appears. See "Context-sensitive menus" on page 130.

## Revised Trax Editor track view area

- ❖ "New track hierarchy" on page 118
- ❖ "New information displayed on clips" on page 121

### New track hierarchy

Since the Trax Outliner has been removed for Maya 6, the way in which tracks appear has changed. We have enhanced groups to help you organize your scene and to create a hierarchy of clips in Trax. Also, the hierarchical relationships between tracks are now shown by their positions in the track view area.

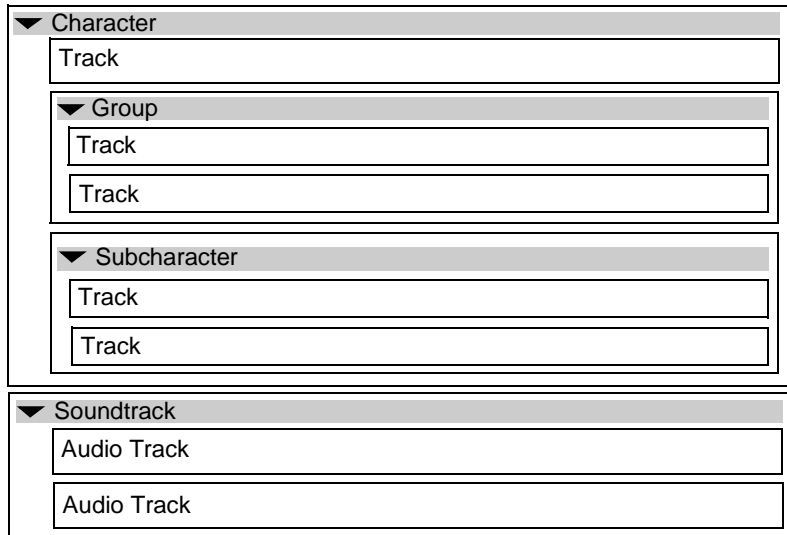

## Characters

The top-most level of each track hierarchy is always the character. A character in Trax can contain multiple tracks, groups, or subcharacters. See "To load characters into Trax" on page 104.

## Groups

Groups contain arbitrary collections of clips for a single character. You can collapse and expand groups just like you would a character. See "To create a group" on page 108.

## Subcharacters

When you add or display a character in Trax, all of its subcharacters are automatically placed under your character. Subcharacters and Groups exist on the same level under the character, and can be controlled in a similar manner. You do not need to have subcharacters to be able to work with a character's animation in Trax.

## 4 | Animation

### > New track hierarchy

#### Summaries

Each level in the Trax hierarchy has a summary. A summary gives you a high level of control over the collection of clips under a character, group, or subcharacter.

You can collapse and expand summaries for characters, subcharacters, or groups by clicking the arrow that is beside each of their names in their respective summaries.

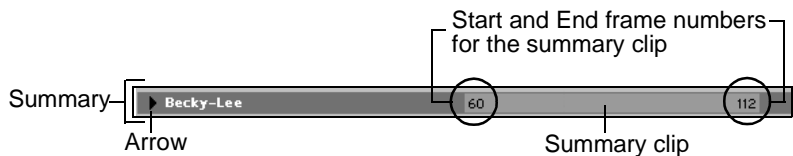

Collapsed set of tracks for a character

The summary clip represents all the clips under your character, group, or subcharacter. The length of a summary clip is determined by the cumulative range of all the clips under its character, group, or subcharacter.

You can drag the summary clip to move all the clips in all the tracks under a character, group, or subcharacter.

You can also scale a summary clip by Shift-dragging its beginning and end or by editing its Start and End frame numbers. When you scale a summary clip, all the clips under its character, subcharacter, or group are also scaled.

#### Soundtrack

You can now display and play multiple audio waveforms in Trax. The new Soundtrack lets you import .wav or .aiff audio files as clips. Once you import an audio file into Trax, you can then move and rename its audio clip.



## 4 | Animation

### > New information displayed on clips

The play priority of audio clips goes from the top-most clip to the bottom-most clip. Also, you can play only one audio clip at a time and any new audio clips that you add to your scene appear at the bottom of the stack of audio tracks in the Soundtrack.

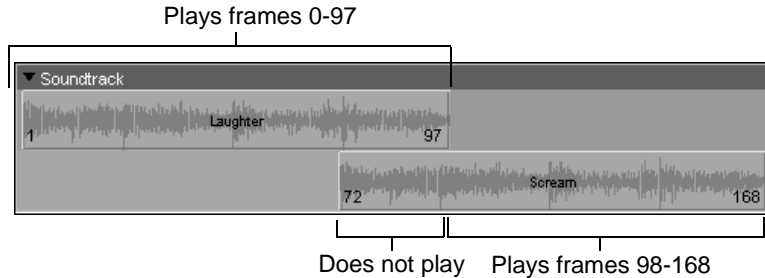

For example, if you have multiple audio tracks and clips that overlap in time, then the audio clip in the top-most track will always play instead of other audio clips on other tracks that are at the same position on the Trax timeline.

If you want to hear the audio clips that are present in your Soundtrack, see "To hear audio clips present in Trax" on page 109.

### New information displayed on clips

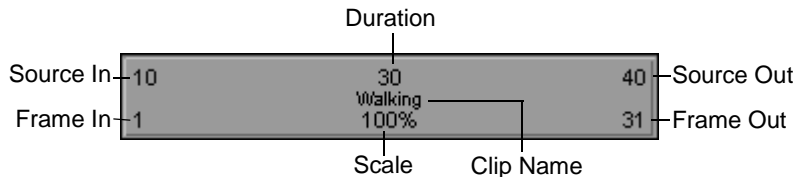

#### Source In/Out

Start and end frame numbers for the range of frames from the source clip contained in this animation clip.

## 4 | Animation

### > New information displayed on clips

When you create an animation clip, a source clip is automatically generated in addition to the clip that is created in the track view area. The source clip is placed in the Visor, and can only be modified from that location. This protects the source clip from being accidentally modified. Any modifications you make to a source clip are reflected in all the clips that originate from that source clip. Source clips are useful if you want to access or revert back to the original animation for a character. For more information on source clips, see *“Nonlinear animation components in Trax”* in the Animation guide.

When you trim a clip in Trax, you are excluding sections of animation from the beginning or end of a clip. This changes a clip’s Source In and Source Out times, but does not affect the source clip itself.

#### Frame In/Out

Current start and end frame numbers for a clip. These numbers control when a clip takes effect.

#### Duration

Number of frames over which the current clip’s source clip takes place. This value is affected by any modifications to the source clip’s Source Start or Source End attributes. Duration is read-only.

For more information on source clips, see *“Nonlinear animation components in Trax”* in the Animation guide.

#### Scale

The scale percentage for the current clip. The scale percentage is the multiplier on the length of the original animation clip. See *“Scale”* on page 125.

#### Editable Clip attributes

You can now change any attributes (for example, name, duration, scale and so on) displayed on clips by double-clicking the attributes and entering a new value.

#### Time warp curve indicator

When you create a time warp for a clip, a new visual cue appears on the respective clip to indicate that it is influenced by a time warp curve.

This visual cue appears as a green colored bar at the top of the clip.

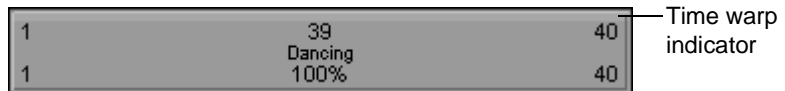

#### Weight curves on clips

When you animate the weight of a clip, a new visual representation of the Weight attribute's curve appears on the clip.

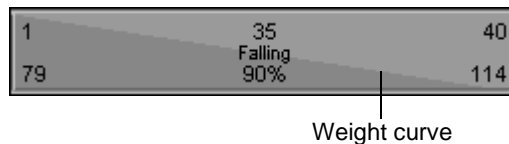

#### Disabled clips

In the new Trax Editor, disabled clips appear dark blue in color. When a clip is disabled, its animation is suppressed during playback. Enabling and disabling a clip is just like muting or unmuting a track.

To enable/disable a clip, right-click the clip and select Enable Clip from the menu that appears. See "Context-sensitive menus" on page 130.

## 4 | Animation

### > Additional clip functionality

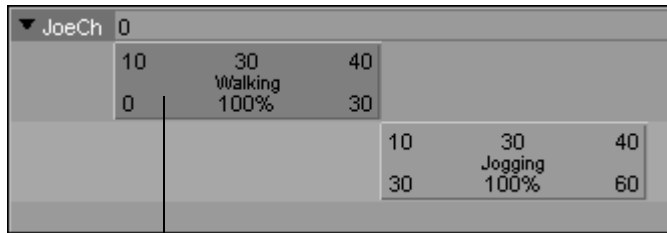

Disabled clip

## Additional clip functionality

### Expression and constraint clips

You can now create clips for animations with expressions or constraints. In the Trax Editor, you can access and edit your expression and constraint clips just like regular animation clips. Expression or constraint clips can contain only expression or constraint channels.

For example, if your animated character has both keyframe animation channels and expression channels, then you have to create a regular clip for the keyframe channels and a separate expression clip for the character's expression channels. See "To create a constraint or expression clip" on page 107.

By separating expressions and constraints from regular animation clips, Maya gives you more control over when expressions and constraints contribute to a character's overall animation sequence.

### Clip interaction controls

Clips now have hotspots which you can drag to produce various effects. For example, if you drag the top-right corner of a clip, you Trim a clip. See "Trim" on page 125, "Scale" on page 125, "Hold" on page 126, and "Cycle" on page 126.

## 4 | Animation

### > Additional clip functionality

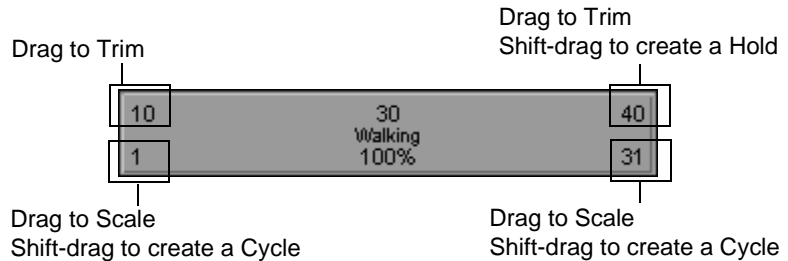

When you move your mouse pointer over a clip, white outlines appear around its hotspots when the pointer passes over them.



#### Trim

Drag the top corner clip hotspots to trim clips.

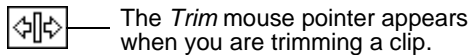

You can omit segments from the beginnings and ends of animation clips by trimming clips. This changes a clip's Source In and Source Out times, but does not affect the clip's source clip itself. See "Source In/Out" on page 121. The segments that you omit from a clip using Trim are not deleted, and can be reinstated if the clip's original length is restored.

#### Scale

Drag the lower corner clip hotspots to scale clips.

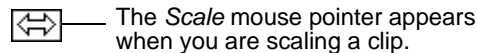

## 4 | Animation

### > Additional clip functionality

When you reduce (<100% of the original clip length) or scale down a clip, you are actually compressing the animation on the clip, so that the resulting animation appears faster or sped up.

When you scale up a clip (>100% original clip length), you are actually extending the animation on the clip, so that the resulting animation appears to be slower.

#### Hold

Shift-drag the upper corner of clips to create holds after the original clip.

 The *Hold* mouse pointer appears when you are creating a hold for a clip.

You can create holds for your animation clips. A hold is a part or an extension of a clip where the last pose is held for a specified period of time. Holds are represented by the letter H.

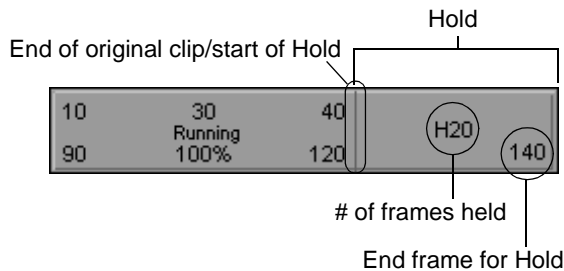

#### Cycle

Shift-drag the lower corners of clips to create cycles before (pre-cycle) or after (post-cycle) the original clip.

 The *Cycle* mouse pointer appears when you are creating a cycle for a clip.

## 4 | Animation

### > Additional clip functionality

You can repeat an animation contained in a clip by extending the clip with duplicate animation sequences called cycles. You can create whole or partial cycles. The end of the original clip, and the beginning of the first cycle, is marked by a small vertical line. The end of each cycle sequence for a clip is marked by a small cycle tick or marker.

Cycles are represented by the letter C and appear a lighter blue than the rest of the clip.

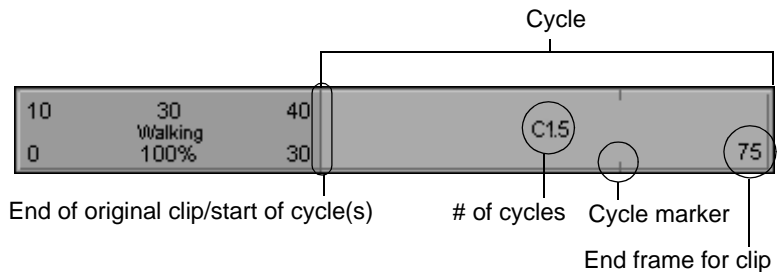

### Scale and move multiple clips at a time

You can now select multiple clips (Shift-click) in one or more characters and move or scale them all at once using the new clip manipulator.

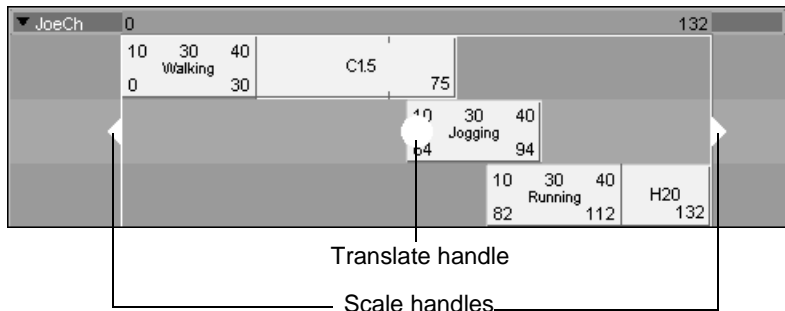

## 4 | Animation

### > Additional clip functionality

For information on how to use the clip manipulator, see “To scale or move groups of clips” on page 109.

### Blends

When you apply a blend to clips, a new visual cue appears on (if clips are overlapping) or between (if there is a gap in time between the clips) the blended clips. Also, the parts of clips that overlap in blends are now colored differently than the rest of the clips.

Blends between animation clips are indicated by green arrows and the regions of overlap between blended clips appear green.

If clips that participate in a blend do not overlap in time, then only a green arrow appears connecting the blended clips. The green arrow is drawn from the end of the first clip in the blend to the beginning of the second clip in the blend.



## 4 | Animation

### > Additional clip functionality

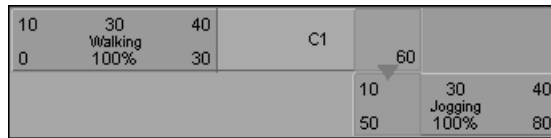

Overlapping clips on different tracks with a blend

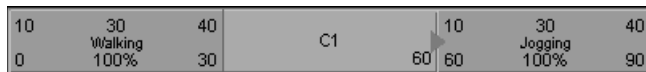
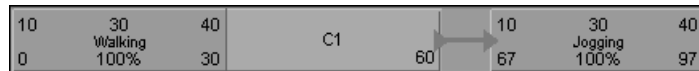

Non-overlapping clips on the same track with a blend

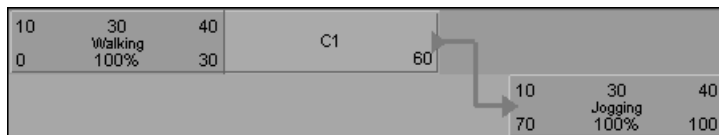

Non-overlapping clips on different tracks with a blend

### To select a blend region

Select the blend's green arrow.

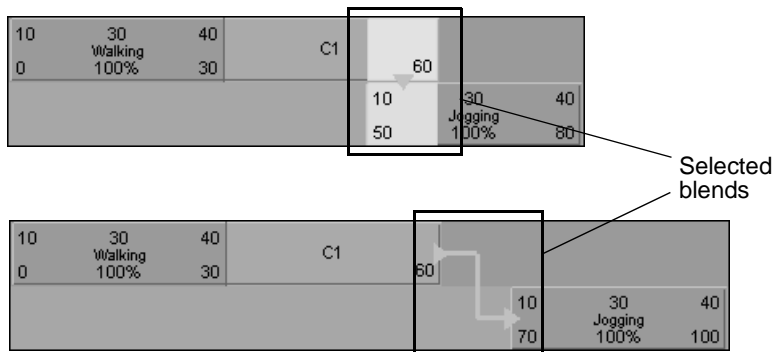

## 4 | Animation

> Additional clip functionality

### To delete a blend

- 1 Select the blend that you want to remove.
- 2 Press Delete.

### To edit a blend's values

- 1 Select the blend that you want to edit.
- 2 Open the Attribute Editor (press Ctrl+n).
- 3 Set the blend's Weight attribute and select a rotation interpolation type from the Rotation Blend drop-down list.

For more information, search the online help for Rotation Type.

### To graph a blend's weight curve

- 1 Select the blend whose curve you want to edit in the Graph Editor.
- 2 Do one of the following:

- In the Trax toolbar, click the Graph Anim Curves  button.
- In the Trax menu bar, select View > Graph Anim Curves.

The Graph Editor appears with the weight curve for the selected animation blend framed in its graph view.

### Context-sensitive menus

Now when you right-click anywhere in the track view area, a context-sensitive menu appears depending on where you click.

This section contains a selection of the available context-sensitive menu items, since most of the options in the context-sensitive menus can be found in the Trax menu bar. See "New Trax Editor menu bar items" on page 110.

For detailed descriptions of all the options that appear in the Trax context-sensitive menus, see *Context-sensitive menu* in the Nonlinear chapter of the Animation guide.

#### Summaries

When you right-click on a summary or a track, the following items are present in the context-sensitive menu that appears:

- **Paste Clip**  
Places the clip copy present in your system's clipboard at the current time in the track, group, or character you are clicking on.
- **Import Clip to Character**  
Lets you import a clip from your disk to the character or group you are clicking on. Opens the Import file browser window.

#### Tracks

- **Paste Clip**  
See above section.
- **Import Clip to Character**  
See above section.
- **Insert Track Above**  
Creates a single, empty track above the track you are clicking on.
- **Insert Track Below**  
Creates a single, empty track below the track you are clicking on.
- **Remove Track**  
Deletes the track—including all the clips it contains—you are clicking on.

## 4 | Animation

### > Additional clip functionality

#### Clips

When you right-click on a single clip, the following items are present in the context-sensitive menu that appears:

- **Enable Clip**  
Lets you enable or disable the clip you are clicking on. When a clip is disabled, the animation on the clip does not play during playback. See "Disabled clips" on page 123.
- **Relative Clip**  
Relative Clip lets you set the offset type for the clip you are clicking on. When on, the selected clip's offset is set to relative. When off, the selected clip's offset is set to absolute.
- **Activate Keys**  
Activate Keys lets you key into a clip from outside of the Trax Editor. When Activate Keys is on for a clip, manipulating and keying the objects whose curves are in that clip from the scene view automatically places all those keys in the clip. Also, when Activate Keys is on for a clip, all that clip's keys appear in the Time Slider. See "Key into clips" on page 133.
- **Select Character Set Members**  
Selects all the objects in the clip's character set in the scene view.
- **Select Source Clip**  
Selects the source clip for the clip you are clicking on.

**Note** In addition to the above items, Blend appears as an option in the context-sensitive menu when two clips are selected.

### Absolute Rotations

With the new Absolute Rotations attribute for clips, you can now specify whether the animation contained in the clip has relative or absolute rotations. This is useful when you want to create a sequence of cycled animation.

For example, if you want to create a walk cycle, the animation clip should have a relative offset (translation) so that your character doesn't jump back to its initial position at the end of each cycle and you want the cycle to have absolute rotations.

### Key into clips

In Maya 6, there are two ways you can key into clips:

- Key into clips from the Trax Editor
- Key into clips from the scene view

### To key into a clip from the Trax Editor

- 1 In the scene view, select and transform an object whose animation curves are in a clip.
- 2 In the Trax Editor, select the clip that contains the animation curves for the object you transformed in step 1.
- 3 Click the Key into Clip icon in the Trax toolbar.

Keys are placed at the current time on all the animation curves in the selected clip. If you key into a clip (original) that has duplicates (dependent copies), those keys are also inserted into the duplicate clips.

### To key into a clip from outside of the Trax Editor

- 1 Select the clip in which you want to place keys.
- 2 Right-click the clip.  
The Trax context-sensitive menu appears.
- 3 Select Activate Keys to turn it on in the menu.

## 4 | Animation

### > What is character mapping?

The clip is now active. The clip turns purple to indicate that when you now set keys for the objects whose animation curves are in the active clip, all those keys are automatically placed in the clip. Also, all the active clip's keys now appear in the Time Slider.

10	30	40
	Walking	
11	100%	41

- 4 In the scene view, transform and key (press s) the objects whose animation curves are in the active clip in Trax.

All keys automatically appear on the animation curves in the active clip in Trax.

## New Character Mapper window

### What is character mapping?

Use the Character Mapper to create a correspondence between a source and target character's nodes or attributes so that you can import and export or copy and paste animation clips between the mapped characters in the Trax Editor.

Mapping or linking one character's nodes and attributes to that of another character creates a characterMap node. This node stores the array of connections between the mapped nodes and attributes. The information stored on this node can only be accessed by Maya.

### How do I map one character to another?

For more information on mapping character animation, see "Character > Character Mapper" on page 138.

## 4 | Animation

> How do I map one character to another?

### To map animation from one character to another

- 1 Select Character > Character Mapper.

The Character Mapper window appears.

- 2 Select the root joint of your source character.

- 3 In the Character Mapper window, click Load Source.

The source character's name appears in the From: field and all the names of its nodes or attributes appear in the left Unmapped column.

- 4 Select the root joint of your target character.

- 5 Click Load Target.

The target character's name appears in the To: field and all the names of its nodes or attributes appear in the right Unmapped column.

- 6 Select one node or attribute from the left unmapped column, and select its corresponding node or attribute in the right column. For example, if the left ankle joint for your source character is *lfoot* and the left ankle joint of your target character is named *joint29*, then your selection would resemble the following:

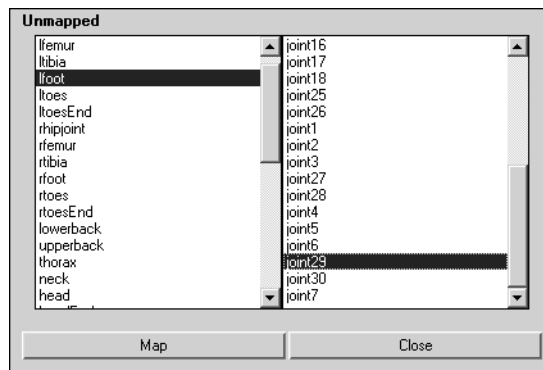

- 7 Click Map.

## 4 | Animation

> How do I map one character to another?

The nodes or attributes that you selected in the Unmapped columns now appear as a pair of nodes or attributes in the Mapped column.

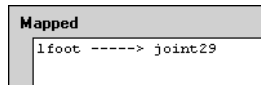

- 8 Repeat steps 6 and 7 until you have mapped all the nodes or attributes from the source and target characters.

Now you can copy and paste animation clips between the mapped characters in the Trax Editor.

### To map animation from one character to another based on hierarchy

- 1 Select the root joint of your source character.
- 2 Shift-click to select the root joint of your target character.
- 3 Select Character > Character Mapper.

The Character Mapper window appears with the source and target characters already loaded.

The name of the first character you selected appears in the From field and all its nodes or attributes appear in the lefthand Unmapped column. The name of the second character you selected appears in the To field and all its nodes or attributes appear in the righthand Unmapped column.

- 4 Do one of the following:
    - In the Character Mapper, select Edit > Map based on hierarchy.
- The character mapper searches for the source and target character's root joints, maps the roots, and then continues down the hierarchy mapping each of the character's nodes or attributes.



- Select a node or attribute from both the Source and Target character.
  - In the Character Mapper, select Edit > Map based on hierarchy.

The character mapper finds the selected nodes or attributes in the Source and Target character's hierarchies, maps those nodes or attributes, and from there continues down the hierarchy mapping each node or attribute. For example, if the you selected the Source and Target character's *left\_hip* joints, then the character mapper would automatically map those nodes and then would continue down the hierarchy (*left\_knee*, *left\_ankle*, and so on) mapping each node.

### Workflow for mapping characters

- Open the Character Mapper window.
- Select the character from which you want to copy clips.

This character is the source character.
- In the Character Mapper, click Load Source.

All the nodes or attributes for the source character appear in the lefthand Unmapped column.

The state of the menu items *Display Node Names* and *Display Channel Names* determines whether node or attribute names appear in the Unmapped and Mapped columns. See "Display Node Names" on page 140 and "Display Channel Names" on page 140.
- Select the character to which you want to paste clips.

This character is the target character.
- In the Character Mapper, click Load Target.

All the nodes and attributes for the target character appears in the righthand Unmapped column.

## 4 | Animation

### > Workflow for mapping characters

- Select pairs of corresponding nodes or attributes from the left and righthand Unmapped columns, and click *Map*.

The mapped pairs of nodes or attributes appear in the Mapped column.

Creating these pairs of mapped nodes or attributes generates a *character map* between the source and target characters. See *characterMap*.

## Character > Character Mapper

The new Character Mapper window lets you map animation from one character (source) to another (target) character. Use the Character Mapper to establish a relationship between a source and target character's nodes or attributes so that you can import and export or copy and paste animation clips between the mapped characters in the Trax Editor.

There are four different ways you can view a character's mapped and unmapped nodes or attributes in the Character Mapper: Hierarchical, Alphabetical, Node, and Channel views. See "Show menu" on page 139. These views can help you better navigate long node or attribute lists (hierarchical or alphabetical) and isolate specific nodes (Node view) or animation channels (Channel view).

The Character Mapper is most useful when you want to map animation from one similar character to another. For example, mapping the animation from the translateX channel of one biped character to the translateZ channel of another biped character.

## 4 | Animation

> Show menu

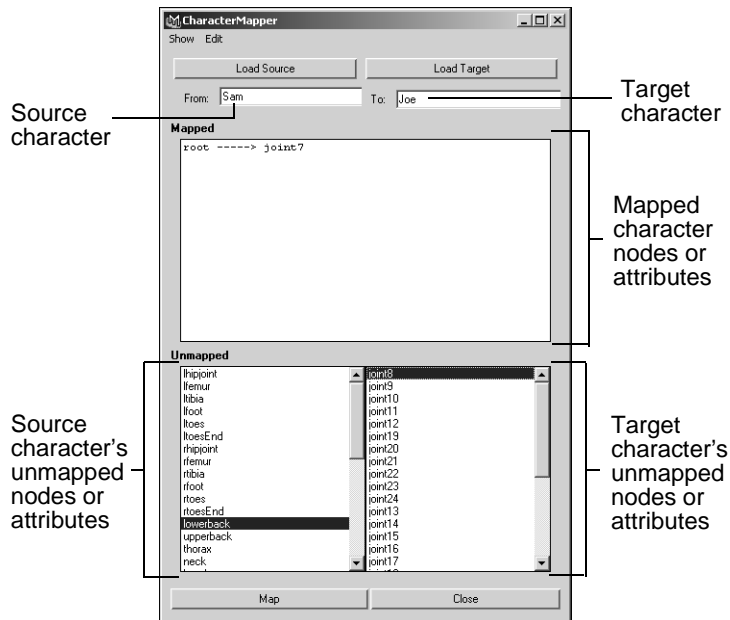

### Show menu

#### Alphabetical

Lists the nodes or attributes in the Mapped and Unmapped columns alphabetically, starting with A.

#### Hierarchical

Lists the nodes or attributes in the Mapped and Unmapped columns by their hierarchical relationships. This means that the nodes or attributes are displayed in parent-child order starting from the root. This option is on by default.

## 4 | Animation

### > Edit menu

#### Display Node Names

Displays all the character set's nodes in the Mapped and Unmapped columns. This option lets you map animation from source to target character nodes. The node view format is as follows:

```
SourceJoint -----> TargetJoint
```

#### Display Channel Names

Displays all the character set's keyable channels in the Mapped and Unmapped columns. Use this option if you need to map animation from certain source character channels to specific target character channels. For example, use this option if you want to map the animation on the X rotation channel for the source character's left shoulder to the Z rotation channel of the target character's left shoulder. The channel view format is as follows:

```
SourceNode.SourceChannel -----> TargetNode.TargetChannel
```

### Edit menu

#### Unmap

Breaks the link between the node or attribute pair selected in the Mapped column.

#### Unmap All

Breaks all the links between the nodes or attributes of the source and target characters that are currently loaded in the Character Mapper. These links or relationships between the nodes or attributes of the source and target characters are displayed in the Mapped column.

#### Clear All

Clears the current contents of the Unmapped and Mapped columns.

## Refresh

Refreshes the Mapped and Unmapped columns to display the most recent (current) version of their contents.

## Map based on node names

Maps the source and target characters by their node or attribute names. Select this menu item when both your source and target character's node or attribute names are the same. For example:

```
lshoulder -----> lshoulder  
lelbow -----> lelbow  
lhand -----> lhand
```

## Map based on hierarchy

Maps the source and target characters by their hierarchical structures. Select this menu item when you want to automatically map the various node hierarchies in your character.

There are two ways you can map your animation based on the hierarchies of the Source and Target characters:

- You can automatically map all the nodes and attributes of the source and target characters. If no nodes or attributes are selected in the Unmapped columns, the Character Mapper will search for the root of the Source and Target characters and will then traverse and map their hierarchies accordingly.
- You can automatically map the nodes or attributes of a specified segment of the character's hierarchy (for example, limb to limb). You specify which segment you want to map by selecting a single Source and a single Target node or attribute at the top of the segment's

## 4 | Animation

### > Fields

hierarchy. The Character Mapper will then map down the segment of each character's hierarchy based on the nodes or attributes you selected.

For example, if you selected the *left\_shoulder* joint of each character, then the Character Mapper will map the Source and Target *left\_shoulder* nodes, and will continue down the hierarchy mapping the *left\_elbow* nodes, the *left\_forearm* nodes, and so on.

See "To map animation from one character to another based on hierarchy" on page 136.

#### Map based on order

Maps the source and target characters by the order (descending) in which their nodes and attributes were added to their character sets. You can view the order of a character's nodes and attributes by expanding their respective character nodes in the Outliner. Select this menu item when both your source and target character's nodes and attributes have the same basic hierarchy. For example:

```
joint3 -----> 3joint  
joint2 -----> 2joint  
joint1 -----> 1joint
```

## Fields

### From:

Displays the name of the source character. The source character set contains the animation data that is remapped to the target character set's skeleton.

### To:

Displays the name of the target character. The target character set's skeleton receives the remapped animation data from the source character set.

## Buttons

### Load Left

Loads all the node or attribute names from the selected character into the Left (source) column.

### Load Right

Loads all the node or attribute names from the selected character into the Right (target) column.

### Map

Creates a correspondence between the animation from the selected source node or attribute (left Unmapped column) to the target node or attribute (right Unmapped column). For example, if you want to map node1 from the source character to node2 of the target character, the node pair or relationship would appear in the Mapped column as the following:

```
node1 -----> node2
```

### Close

Closes the Character Mapper window.

## Columns

### Mapped

Displays all the node or attribute relationships between the source and target character sets. Once you link nodes or attributes by clicking them in the source (left) and target (right) Unmapped columns, the linked pairs appear in the Mapped column.

### Unmapped

The left unmapped column lists all the nodes or attributes from the source character set's skeleton, and the right unmapped column lists all the nodes or attributes from the

## 4 | Animation

### > What is motion redirection?

target character set's skeleton. To link pairs of nodes or attributes, see "To map animation from one character to another" on page 135.

## Redirecting motion

### What is motion redirection?

You can now redirect the motion of character animation more easily than before. Redirecting motion is the process by which you can modify a character's path or orientation at anytime during its animation. For example, by redirecting a character's motion, you can change where a character lands, as well as the direction the character is facing, at the end of a character's jump animation.

You can use the new redirection controls to move and rotate a character, and key these new positions and orientations, at any point during its animation.

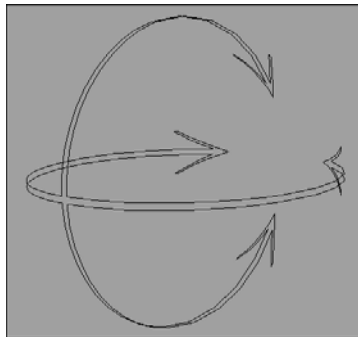

Rotation redirection control

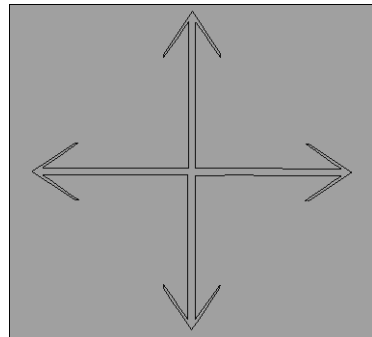

Translation redirection control



---

**Note** You can use the redirection controls to redirect any type of motion in Maya (keyframe or motion capture animation, expressions, dynamics, and so on).

---

## Workflow for redirecting animation

- 1** Step forward in your animation to where you want your character's redirection to occur.
- 2** Select the character (if you are redirecting an entire character, this would be its root joint) or the part of a character (if you are redirecting the motion of a character's back, this would be one of its spine joints) you want to redirect.
- 3** Create the desired (translation, rotation, or translation and rotation) redirection controls. See "To redirect an object's animation" on page 147.
- 4** Reposition your redirection controls.
  - For the rotation redirection control, move it to the point around which you want your character to rotate. For example, if you want to use the rotation redirection control to make a character go around a corner during its walk cycle, you would move the rotation redirection control to the ball of the foot the character pivots on when rounding the corner.
  - For the translation redirect control, move it to where you want the character or the part of a character to move to.
- 5** Step backward in your character's animation to where you want the character's redirection to begin.
- 6** Key the appropriate channels for your controls.

You have to first key your controls at their base values. Base values are the values of the control's Rotate and Translate channels at the time of the control's creation.

## 4 | Animation

> Related topics

- 7 Step forward in your character's animation to where in the Trax timeline you inserted the redirection controls.
- 8 Manipulate your redirection controls.
  - Rotate your rotation redirection control.
  - Translate your translation redirection control.
- 9 Key the Rotate or Translate channels for your redirection controls once again.

This forms the redirection animation that redirects the character's original animation.

### Related topics

- ❖ "Animation redirection example" on page 148
- ❖ "To map animation from one character to another" on page 135
- ❖ "To map animation from one character to another based on hierarchy" on page 136

## How do I redirect the motion of an animated character?

### To redirect a character set's animation

- 1 Step forward in your animation to where you want your character's redirection to occur.
- 2 Select the character set whose animation you want to redirect.
- 3 Select Character > Create Character Set > .  
The Create Character Set Options window appears. See Character > Create Character Set in the Character Setup guide.
- 4 Set the options in the Character and Attributes sections as desired.

## 4 | Animation

> How do I redirect the motion of an animated character?

- 5** In the Redirection section, turn on Redirect Character.
- 6** Do the following:
  - If you want to redirect the rotation of your character, turn on Rotation Only.
  - If you want to redirect the translation of your character, turn on Translation Only.
  - If you want to redirect the rotation and translation of your character, turn on Rotation and Translation.
- 7** Click Apply.

Rotation and/or translation redirection controls appear at the root of the current character set. The Create Character Set Options window remains open.
- 8** Do the following:
  - Move the rotation redirection control to change the position around which your character pivots.
  - Move the translation redirection control to change the current character's position relative to the position around which your character pivots.
- 9** Do steps 5 to 9 in the redirection workflow. See "Workflow for redirecting animation" on page 145.

### To redirect an object's animation

- 1** Step forward in your animation to where you want your object's redirection to occur.
- 2** Select the root of the object whose motion you want to redirect.
- 3** Select Character > Redirect > .

The Character Redirection Options window appears.
- 4** In the Redirection Type section, do the following:

## 4 | Animation

### > Animation redirection example

- If you want to redirect only the rotation of your character, turn on Rotation Only.
  - If you want to redirect only the translation of your character, turn on Translation Only.
  - If you want to redirect both the rotation and translation of your character, turn on Rotation and Translation.
- 5** Do one of the following:
- Click Redirect. The rotation and/or translation redirection controls appear at the root of the object and the Character Redirection Options window closes.
  - Click Apply. The rotation and/or translation redirection controls appear at the root of the object and the Character Redirection Options window remains open.
- 6** Do the following:
- Move the rotation redirection control to change the position around which your character pivots.
  - Move the translation redirection control to change the current character's position relative to the position around which your character pivots.
- 7** Do steps 5 to 9 in the redirection workflow. See "Workflow for redirecting animation" on page 145.

## Animation redirection example

### *Scenario*

You want to modify the walk cycle animation of a biped character so that during its walk cycle the character turns a corner and then walks down a ramp.

### To make a biped character turn a corner during its walk cycle

- 1 Step forward in the character's animation until you locate the point at which you want the character to turn around the corner, then stop the animation at a place in the walk cycle where the left foot of the biped character is on the ground.

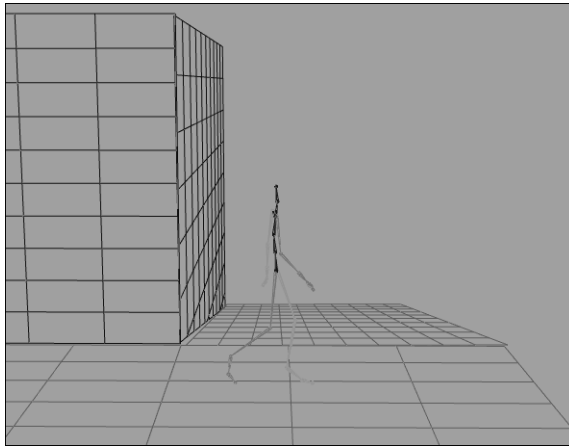

- 2 Select the root joint of the character's skeleton.  
When redirecting the motion of a character, you want to create redirection controls for the parts of the character whose translation or rotation you want to change during its animation. In this scenario, the root joint is selected because we want to modify the orientation of the character's entire body during its walk cycle.
- 3 In the Animation menu set, select Character > Redirect > .  
The Redirection Options window appears. See "Character > Redirect" on page 160.
- 4 Turn on Rotation Only and click Redirect.

## 4 | Animation

### > Animation redirection example

The rotation redirection control appears at the root joint of the character.

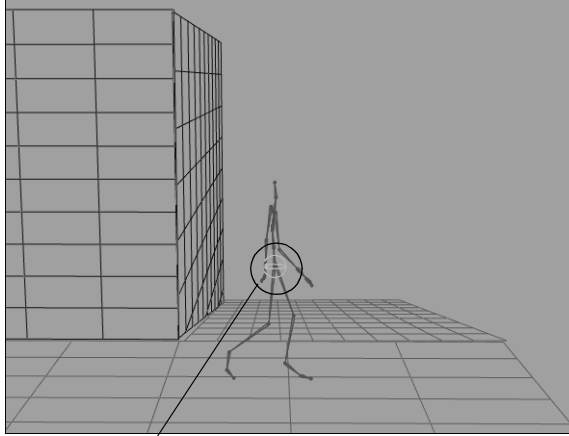

Rotation redirection control

- 5** Select the rotation redirection control and using the Translate Tool, move the control to the tip of your character's left foot.

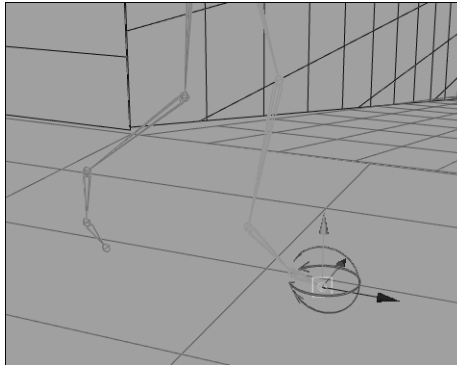

## 4 | Animation

### > Animation redirection example

Moving the rotation redirection control lets you reposition the point around which the biped character pivots. In this scenario, you want the character to pivot on the ball of its left foot when it turns the corner.

- 6** In the Channel Box, key the Rotate X, Y, and Z channels for the left foot's rotation redirection control.
- 7** Step forward in the animation until the right foot is on the ground and the left foot's heel is raised.

This is where the character will begin its turn.

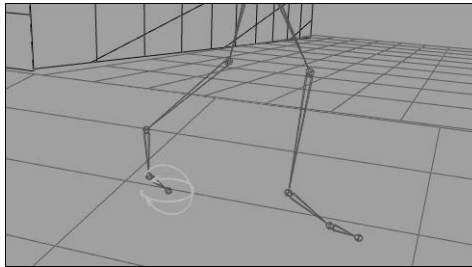

- 8** Select the left foot rotation redirection control, rotate it 45 degrees, and key its Rotate X, Y, and Z channels.

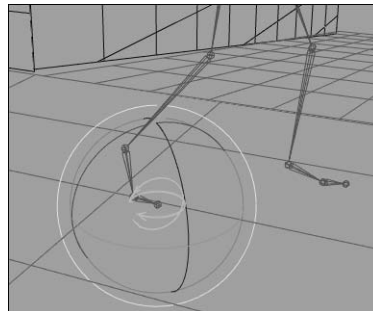

- 9** Select the character's root joint and select Character > Redirect.

A rotation redirection control appears at the character's root.

## 4 | Animation

### > Animation redirection example

- 10 Select the rotation redirection control and using the Translate Tool, move the control to the tip of your biped's right foot.

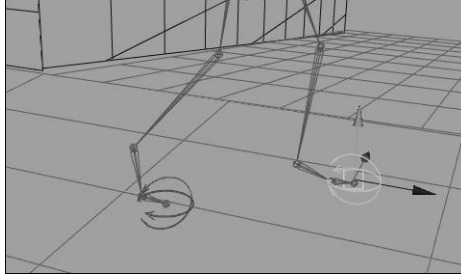

- 11 In the Channel Box, key the Rotate X, Y, and Z channels for the right foot's rotation redirection control.
- 12 Step forward in the animation until the left foot is once again on the ground and the right foot's heel is raised. This is the point where the character will begin its descent down the ramp.

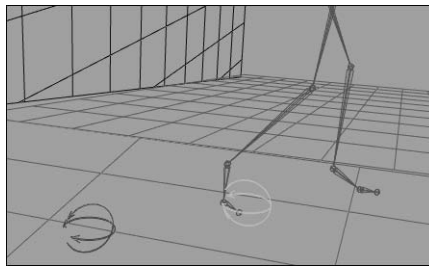

- 13 Select the right foot's rotation redirection control, rotate it 45 degrees, and key its Rotate X, Y, and Z channels.



## 4 | Animation

### > Animation redirection example

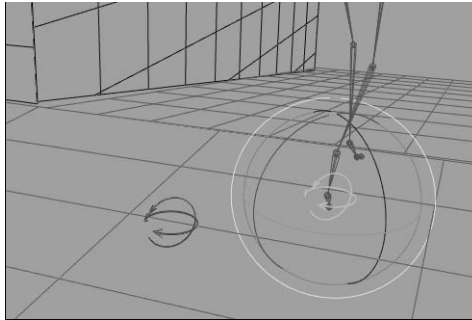

**14** Go to the beginning of the animation's playback range and play the animation.

The character now walks and turns left around the corner.

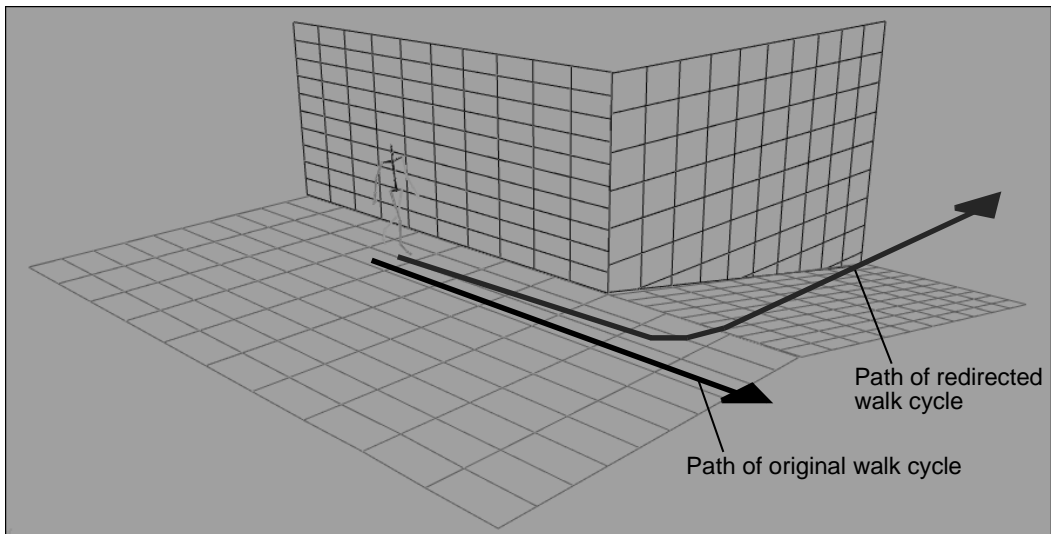

## 4 | Animation

> Animation redirection example

### To make a biped character walk down a ramp during its walk cycle

- 1 Step forward in the animation until you reach the frame where the character is just about to walk down the ramp.

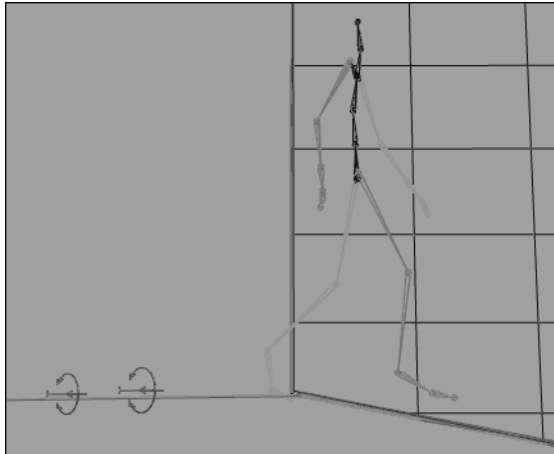

- 2 Select the root joint of the character.
- 3 In the Animation menu set, select Character > Redirect > . The Redirection Options window appears. See "Character > Redirect" on page 160.
- 4 Turn on Rotation and Translation and click Redirect. The rotation and translation redirection controls appear at the root joint of the character.

## 4 | Animation

### > Animation redirection example

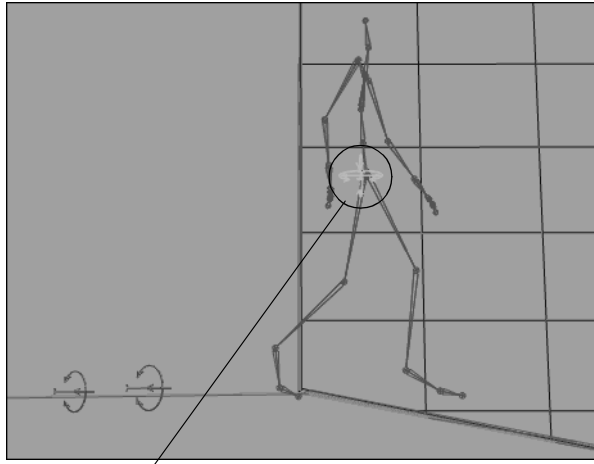

Rotation redirection control

- 5** Select the rotation and translation redirection controls and using the Translate Tool, move the controls to the tip of your biped's right foot.

## 4 | Animation

> Animation redirection example

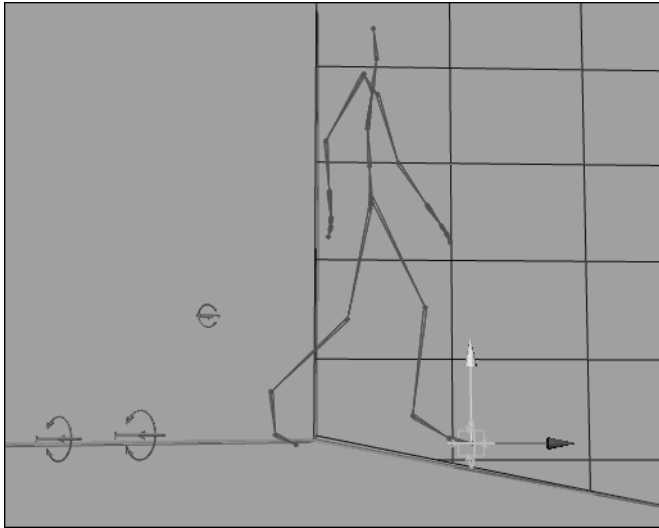

- 6 Step back a few frames until the character appears to be standing on the edge of the ramp with both feet side-by-side.

## 4 | Animation

### > Animation redirection example

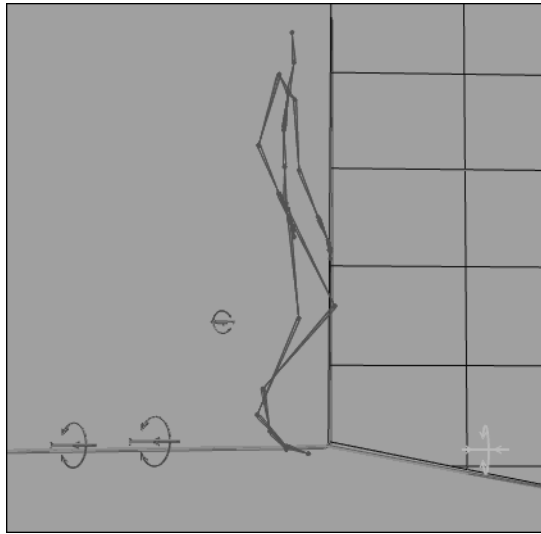

- 7** Do the following:
  - For the rotation redirection control, key all its Rotate X, Y, and Z channels.
  - For the translation redirection control, key all its Translate X, Y, and Z channels.
- 8** Step forward in the animation to the point where you inserted the redirection controls.
- 9** Select the rotation redirection control and using the Rotate Tool, rotate the control until the character's feet are parallel to the ramp.

## 4 | Animation

### > Animation redirection example

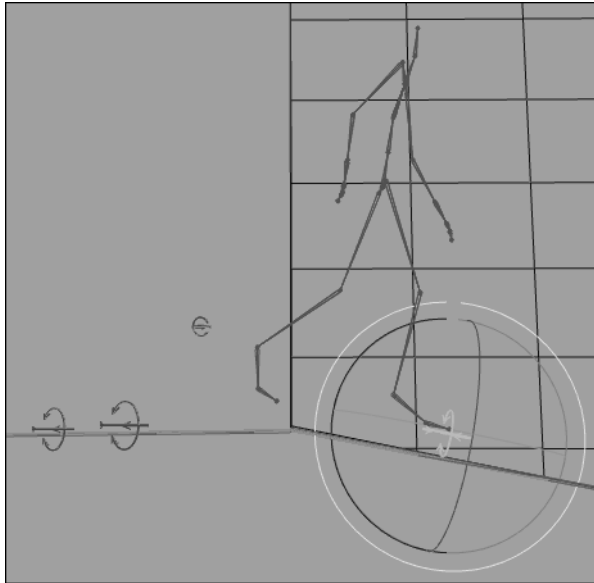

Note that there is a gap between your character's feet and the floor/ramp.

- 10** In the Channel Box, key the rotation redirection control's Rotate X, Y, and Z channels.
- 11** Select the translation redirection control and using the Move Tool, translate your character downward until the right foot touches the ramp and the left foot touches the floor.

## 4 | Animation

### > Animation redirection example

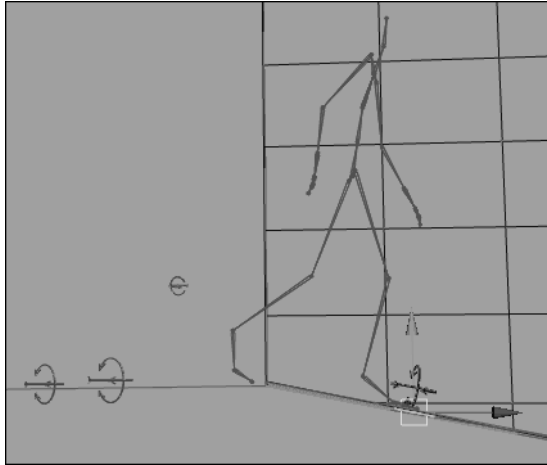

**12** In the Channel Box, key the translation redirection control's Translate X, Y, and Z channels.

**13** Go to the start of the animation's playback range and play your animation.

After the character turns the corner, it now walks down the ramp.

## 4 | Animation

> Character > Redirect > □

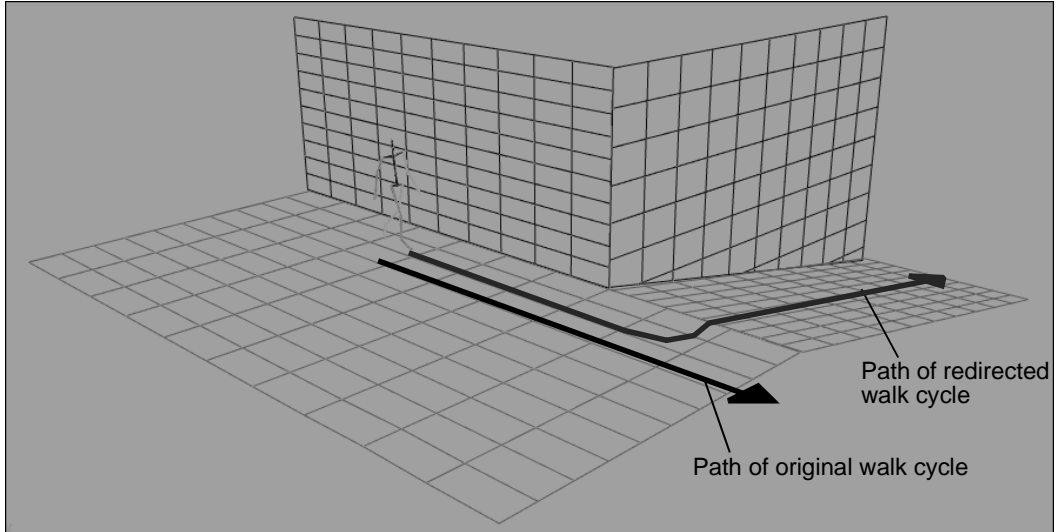

### Character > Redirect

Adds translation and/or rotation redirection controls to the current character. The controls appear at the origin of the character.

When a character is redirectable, you can change the translation and orientation of its already established (for example, motion capture) animation.

### Character > Redirect > □

When you select this menu item, the Character Redirection Options window appears.



#### Redirection Type

##### Rotation and Translation

Creates a rotation and translation control for the current object.

##### Rotation Only

Creates a rotation redirection control for the current character. The rotation redirection control appears at the origin of the current object.

The rotation redirection control is useful if you want to change the orientation of the point around which your object pivots. For example, you can manipulate a rotation redirection control to get a character to turn 90 degrees (around a corner perhaps) halfway through its walk cycle.

##### Translation Only

Creates a translation redirection control for the current character set. The translation redirection control appears at the origin of the current object.

The translation redirection control is useful if you want to change the translation of the point around which your object pivots. For example, you can manipulate the translation redirect controls to change the place at which a character lands from a jump.

## Redirection in the Character Set Options window

The following options are located in Character > Create Character Set > .

## 4 | Animation

### > Redirection in the Character Set Options window

#### Redirect Character

Makes the current character set redirectable. When a character set is redirectable, this means that you can now change the translation and orientation of already established (for example, motion capture) animation.

#### Rotation and Translation

Creates a rotation and translation control for the current character set.

#### Rotation Only

Creates a rotation redirection control for the current character set. The rotation redirection control appears at the origin of the current character.

The rotation redirection control is useful if you want to change the orientation of your character set's pivot. For example, you can manipulate a rotation redirection control to get a character to turn 90 degrees (around a corner perhaps) halfway through its walk cycle.

#### Translation Only

Creates a translation redirection control for the current character set. The rotation redirection control appears at the origin of the current character.

The translation redirection control is useful if you want to change the translation of the point around which your object pivots. For example, you can manipulate the translation redirection control to change the place at which a character lands from a jump.

## Miscellaneous improvements

### Exposed muting in the Dope Sheet and Graph Editor

When you mute an animated object's keys or channels, a Mute channel is generated for each animation channel. You can view, manipulate, and add keys to this Mute channel or curve in the Dope Sheet or Graph Editor. This is useful when you want to isolate and review specific parts of your animation.

When you edit a Mute channel or curve, its corresponding animation curve automatically updates in the Dope Sheet and Graph Editor view areas.

### How do I mute or unmute a channel in the Dope Sheet or Graph Editor?

- 1 Open the Dope Sheet or Graph Editor.
- 2 In the Dope Sheet or Graph Editor's outliner, select the channel you want to mute.
- 3 Do one of the following:
  - If the current animation curve is not muted, select Curves > Mute Channel.

In the Graph Editor or Dope Sheet, Mute appears under the current animation channel's name in the outliner and a Mute curve or channel appears in the view area.

The muted animation curve now appears as a dotted line in the graph view.

## 4 | Animation

> How do I mute keys in the Dope Sheet or Graph Editor?

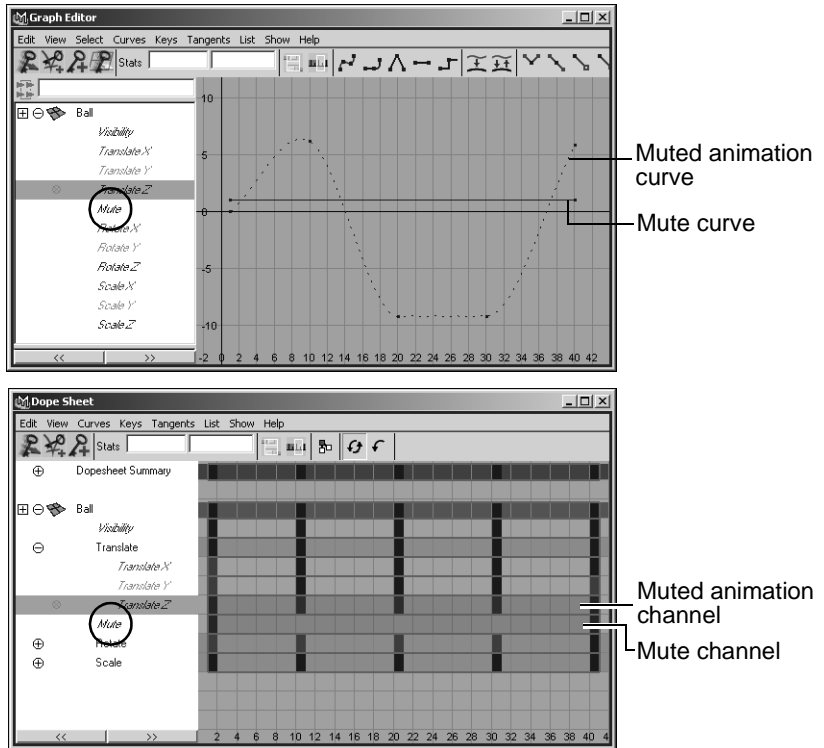

- If the current animation curve is muted, select Curves > Unmute Channel.

The current animation curve's Mute node is deleted, and all occurrences of Mute are removed from the Graph Editor's and Dope Sheet's outliners and views.

## How do I mute keys in the Dope Sheet or Graph Editor?

- 1 Open the Dope Sheet or Graph Editor.

## 4 | Animation

> How do I mute keys in the Dope Sheet or Graph Editor?

- 2 In the outliner, select the animation channel that has the key you want to mute.
- 3 In the view, select the key you want to mute.
- 4 Do one of the following:
  - If the current key is not muted, select Keys > Mute Key On.

The current key now no longer contributes to the animation on its channel. In the Graph Editor or Dope Sheet, Mute appears under the current animation channel's name in the outliner and a Mute curve with keys appears in the view area.

## 4 | Animation

> How do I mute keys in the Dope Sheet or Graph Editor?

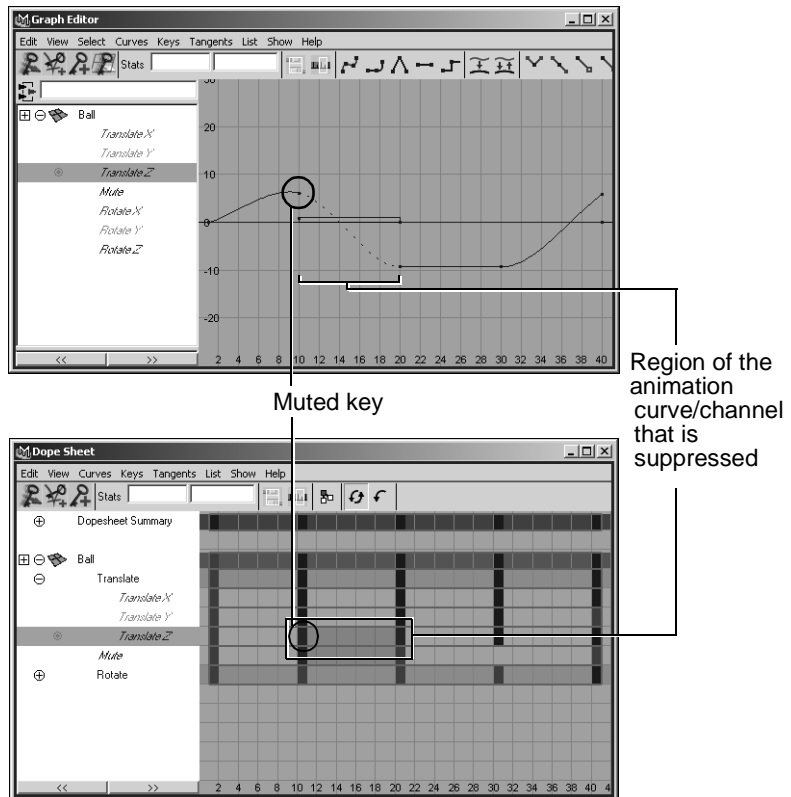

The Mute curve has the same number of keys and they are positioned the same as those on its animation channel.

- If the current key is muted, select **Keys > Mute Key Off**.

The current key now contributes to the animation on its channel. Unmuting a key does not remove the Mute curve. To remove the Mute curve from the current animation channel, see "How do I mute or unmute a channel in the Dope Sheet or Graph Editor?" on page 163.

> New ways to manipulate keys and curves in the Graph Editor

## New ways to manipulate keys and curves in the Graph Editor

### Manipulate groups of keyframes

You can now manipulate groups of keys proportionally or in relation to a selected key using the new Move Function options. The Move Keys Tool and the Move Function options can be accessed through the Graph Editor's menu bar by selecting Edit > Transformation Tools > Move Keys Tool > .

## 4 | Animation

> Manipulate groups of keyframes

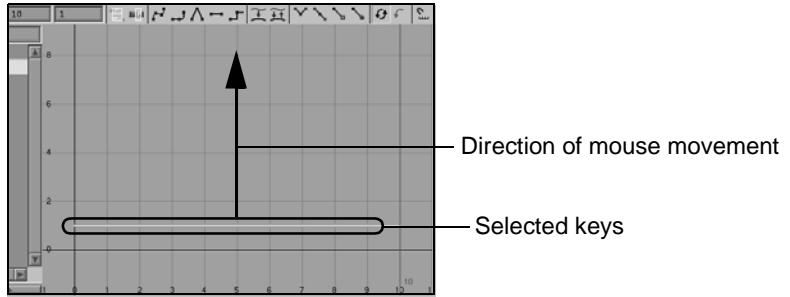

Before move

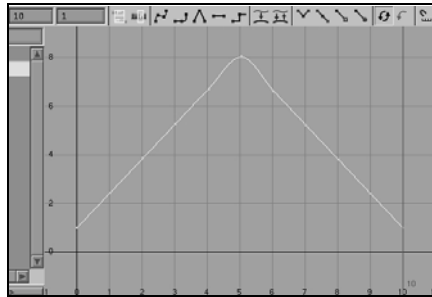

Result with Linear falloff

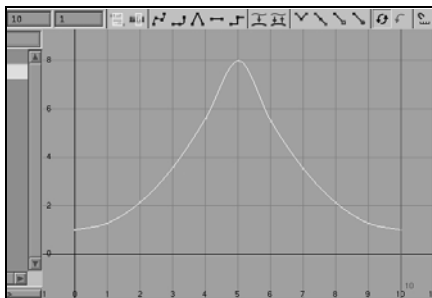

Result with Exponential falloff



### > Manipulate curves with the lattice manipulator

#### Move Falloff

Constant	Moves all keys the same amount in the direction of the mouse movement.
Linear	Moves all keys based on the distance they are from the mouse down location. The amount a key moves decreases linearly as its distance from the mouse down location increases.
Exponential	Moves all keys based on the distance-squared they are from the mouse down location. The amount a key moves decreases exponentially as its distance from the mouse down location increases.

## Manipulate curves with the lattice manipulator

You can now manipulate curves in the Graph Editor with the new Lattice Deform Keys Tool.



Lattice Deform Keys Tool

The Lattice Deform Keys Tool lets you draw a lattice deformer around groups of keys, so that you can deform many keys at once. This tool gives you a high-level of control over your animation curves.

Once you draw a lattice around a group of keys, you can then move the control points of the lattice to deform the affected animation curves or scale the lattice points around a selected control point to transform the affected curves.

You can also use the Lattice Deform Keys Tool to deform keys that lie along a single (horizontal or vertical) graph view axis.

## 4 | Animation

### > Manipulate curves with the lattice manipulator

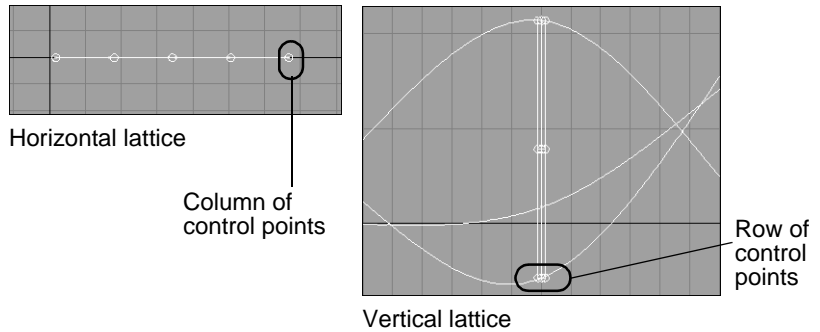

**Note** When using the Lattice Deform Keys Tool to deform keys that lie on a single axis, selecting one lattice point in a row (vertical) or column (horizontal) selects all the points in that row or column.

For example, if you select a lattice control point on a horizontal lattice, all of the lattice points in the selected point's column are also activated. Depending on your current dolly-view scale in the Graph Editor, not all the selected lattice points may be visible. The visibility of the selected lattice points does not affect the functioning of this tool.

### Lattice Settings

#### Columns

Specifies the number of columns for the current lattice manipulator. The minimum number of columns is 2 and maximum number is 20.

#### Rows

Specifies the number of rows for the current lattice manipulator. The minimum number of rows is 2 and the maximum number is 20.

#### Falloff

Specifies the lattice manipulator's level of influence or falloff value.

#### Middle Button Scales

When on, you can scale the active control points around the current lattice point.

#### How do I use the Lattice Deform Keys Tool?

#### **To deform animation curves with the lattice manipulator**

- 1** Select the Lattice Deform Keys Tool from the Graph Editor's toolbar.
- 2** Set the Lattice Deform Keys Tool options from the Tool Settings window.  
See "Lattice Settings" on page 170.
- 3** Select keys on the curves you want to deform to define the target curve region.  
The lattice appears in the graph view. The lattice forms a bounding box around the selected keys.

## 4 | Animation

> Manipulate curves with the lattice manipulator

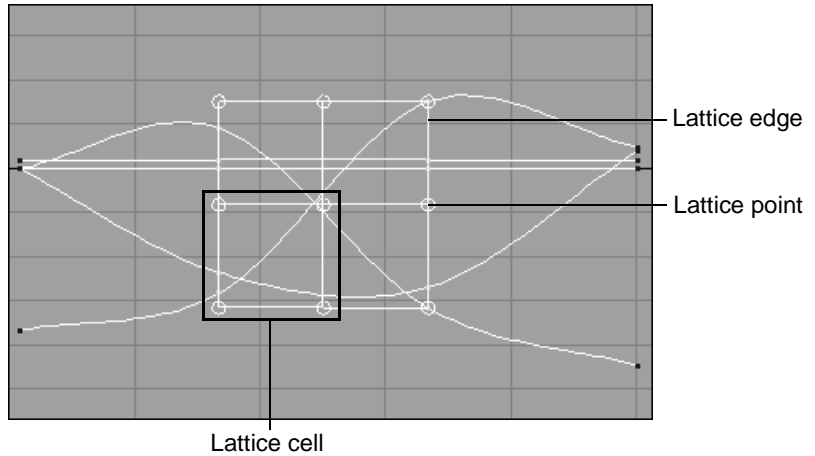

- 4** Select the lattice points, lattice edge, or lattice cell you want to manipulate by clicking them with the left mouse button.  
Shift-click lattice points to include them in or remove them from your selection. You cannot select more than one lattice edge or cell at a time.
- 5** Do one of the following:
  - For lattice edges, cells, or single points, drag to deform the target curve region.

## 4 | Animation

> Manipulate curves with the lattice manipulator

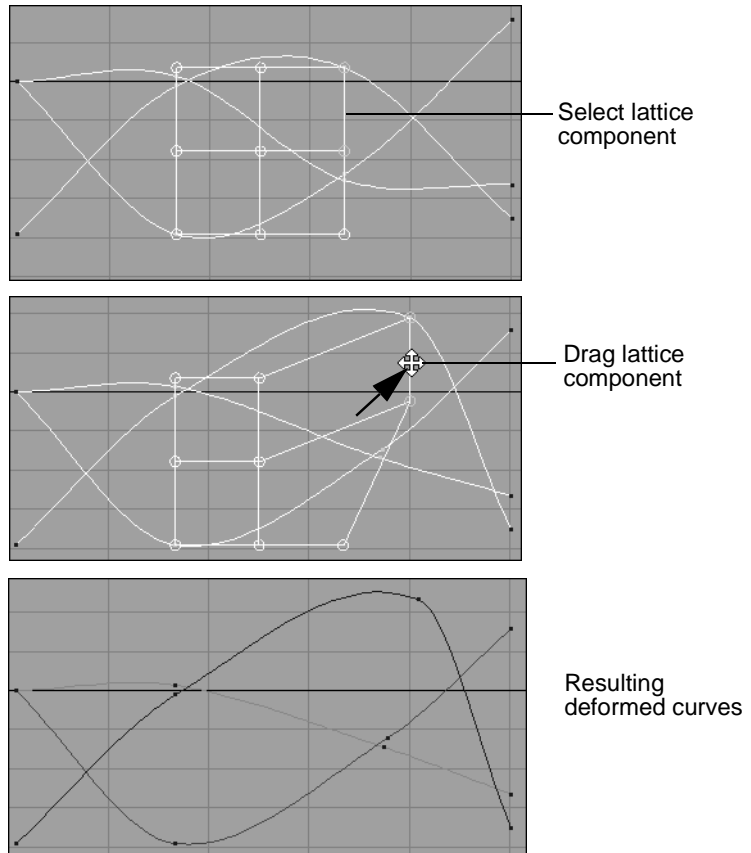

- For groups of lattice points, middle-drag to deform the target curve region.

## 4 | Animation

> Manipulate curves with the lattice manipulator

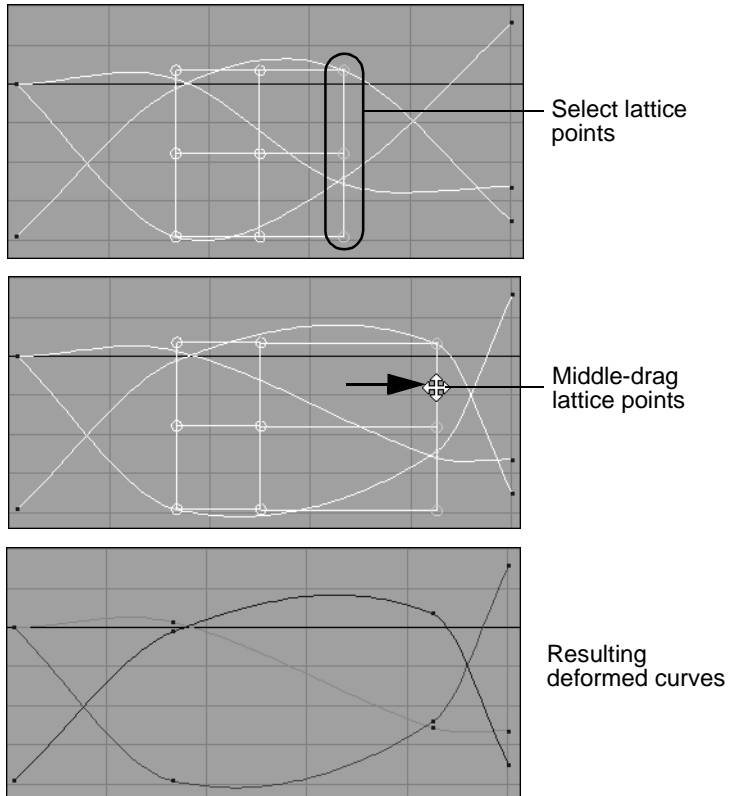

- If you want to scale a region of the lattice, turn on the Middle Button Scales option in the Lattice Deform Keys Tool and then middle-drag to scale the selected lattice region. Scaling the lattice deforms the affected curves.

## 4 | Animation

### > Customize animation curve colors

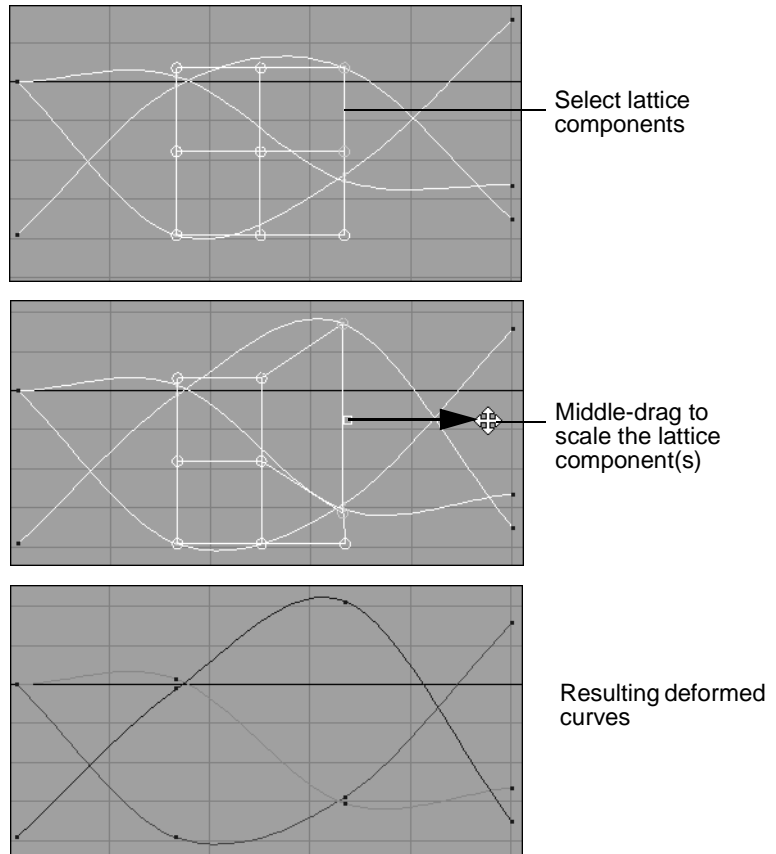

## Customize animation curve colors

You can now specify custom colors for the animation curves that appear in the Graph Editor. With the new Use Curve Color and Curve Color attributes you can set the colors for individual curves or use more global operations such as coloring a curve based on which characters they drive to color groups of curves at a time.

## 4 | Animation

### > Customize animation curve colors

This type of global operation can be achieved through MEL scripts. For a sample MEL script, see “Example MEL procedure for customizing the color of multiple animation curves” on page 184.

All user-defined color settings for animation curves appear in both the Graph Editor’s Outliner and graph view. The Use Curve Color checkbox and Curve Color swatch are located in the Anim Curve Attributes section of each animation curve node (for example, *animCurven*).

To switch between your custom colors and the default curve colors, turn Use Curve Color on or off.

**Note** The maximum number of custom colored curves that can be displayed at any one time is 20. When this number is exceeded, curves are displayed using their default colors.

#### **To set custom animation curve colors**

- 1** Select the animated object.
- 2** Open the Graph Editor.
- 3** In the graph view, select the animation curve.
- 4** Select Curves > Spreadsheet.  
The Attribute Editor opens.
- 5** In the Anim Curve Attributes section of the *animCurven* tab, turn on Use Curve Color.
- 6** Double-click the color swatch to launch the Color Chooser.
- 7** In the Color Chooser, select a custom color for the curve and click Accept.



The color you selected with the Color Chooser appears in the Curve Color swatch. In the Graph Editor's graph view, the animation curve is now the color of the Curve Color swatch.

## Additional time working units available

The following time working units have been added for animation playback in Maya 6:

2, 3, 4, 5, 6, 8, 10, 12, 16, 20, 40, 75, 80, 100, 120, 125, 150, 200, 240, 250, 300, 375, 400, 500, 600, 750, 1000, 1200, 1500, 2000, 3000, and 6000 fps (frames per second).

You can set the playback rate from the Time drop-down list in Window > Settings/Preferences > Preferences > Settings > Working Units.

## Control what parts of characters are ghosted

With the new Object Type options, you can specify which parts of a character are ghosted. The Object Type options are located in Animate > Ghost Selected > . For more information on ghosting, see *"Previewing animation"* in the Animation guide.

For hierarchical characters, turn on Hierarchy in the Ghost Selected Options window if you want to limit which parts of a character's children are ghosted.

### Object Type

Geometry	Only the geometry of the current object is ghosted.
Locator	Only the locators for the current object are ghosted.
Joint	Only the joints and bones for the current object are ghosted.

## 4 | Animation

### > Playblast specified frames

All Other  
Types

Only the parts of the current object that are not geometry, locators, or joints are ghosted.

## Playblast specified frames

You can now output single frames of your animation to Playblast using the new `-frame` flag for the `playblast` MEL command. For example:

```
playblast -frame 1 -frame 4 -frame 7
```

outputs frames 1, 4, and 7 of your current animation to Playblast. For more information, see [Help > MEL Command Reference](#).

**Note** The `-frame` flag overrides any `-startFrame`/`-endframe` flags.

## Off-screen Playblast (IRIX and Linux only)

You can now run Playblast when Maya is minimized on your screen using the new `-os/offScreen` flag for the `playblast` MEL command. For more information, see [Help > MEL Command Reference](#).

## Advanced additions to animation

### Bake referenced animation

You can now bake referenced animation data using the `bakeResults` and `bakeSimulation` MEL commands. See [Help > MEL command reference](#). You can also bake referenced simulation data using [Edit > Keys > Bake Simulation](#).

## New MEL flags for importing and exporting animation

You can now import and export all or selected main scene animation as well as referenced animation with the new `-ean/exportAnim`, `-eas/exportSelectedAnim`, `-ear/exportAnimFromReference`, and `-esa/exportSelectedAnimFromReference` flags for the `file` MEL command.

For information on using MEL, see the MEL guide. For information on specific MEL commands like `file`, see `Help > MEL command reference`.

### Main scene animation data

#### `-ean/exportAnim`

This flag lets you export all the animation nodes and connections in your scene.

#### `-eas/exportSelectedAnim`

This flag lets you export all the animation nodes and connections for the selected objects in your scene.

### Referenced animation data

#### `-ear/exportAnimFromReference`

This flag lets you export the animation nodes and connections for all referenced objects in a scene. This flag can be used in conjunction with `-rfn/referenceNode` to constrain what is exported to only animation for referenced objects in a specific reference file. You can export the animation nodes and connections as `mayaAscii` or `mayaBinary`. For example:

```
file -type "mayaAscii" -exportAnimFromReference "C:\animExport.ma";  
file -type "mayaBinary" -exportAnimFromReference -rfn "geomRN"  
"C:\animExportRN.ma";
```

## 4 | Animation

### > Referenced animation data

#### **-esa/exportSelectedAnimFromReference**

This flag lets you export the animation nodes and connections for selected referenced objects in a scene. This flag can be used in conjunction with `-rfn/referenceNode` to constrain what is exported to only animation for referenced objects in a specific reference file. You can export the animation nodes and connections as `mayaAscii` or `mayaBinary`. For example:

```
file -type "mayaAscii" -exportSelectedAnimFromReference  
"C:\animExportSelected.ma";  
file -type "mayaBinary" -exportSelectedAnimFromReference -rfn "geomRN"  
"C:\animExportSelRN.ma";
```

#### **-sns/swapNamespace**

This flag lets you replace a given namespace with a different namespace when importing or referencing a file. This flag has two parameters that must be specified. The first parameter is the namespace to be replaced (`fromNamespace`) and the second is the new namespace (`toNamespace`). The `toNamespace` parameter must already exist in the scene prior to calling `swapNamespace`. `swapNamespace` can be used multiple times in a single file command call to swap multiple namespaces when importing or referencing a file.

---

**Note** The `swapNamespace` flag is saved out as both `mayaAscii` and `mayaBinary` formats for file references whose namespaces were swapped on reference.

---

For example:

```
file -reference -swapNamespace "fromName" "toName" "C:\animExport.ma";  
file -import -swapNamespace "name1" "name2" -swapNamespace "name3"  
"name4" "C:\anim.ma";
```

### > Limitations to the new import and export animation flags

The namespace parameters operate on the current namespace. Thus when referencing a file, a new namespace is created for the file reference that is equivalent to the name of the file being referenced. If the namespace that you are swapping to is outside that namespace domain, a full namespace path must be specified. For example:

```
file -reference -swapNamespace "fromName" ":toName" "C:\animExport.ma";
```

The colon in front of the `toNamespace` parameter specifies a namespace path starting from the root namespace.

### Limitations to the new import and export animation flags

- The new `file` command flags work only with the Maya namespace capability, not prefixes.
- The files (Animation Data Files) created using these new flags will contain only animation curve nodes, their connections, and the associated animation nodes that are required for type conversion.
- You must retain the namespace information used during the creation of the animation reference file since both the original and new model namespaces are required at the time of animation import. Otherwise, you will not be able to reuse the exported animation.
- When building a scene that reuses animation using the new `file` command flags, the models must be referenced in first and then the Animation Data File can be referenced. Otherwise, Maya will not be able to resolve the connections defined in the Animation Data File.
- The new `file` command flags are intended to work with single level file references. Multi-level referencing, where references are contained within references, is not supported.

## 4 | Animation

> How do I use these new file command flags?

### How do I use these new *file* command flags?

#### Example workflow:

*Importing animation as a reference from a low resolution model in one file (reference scene) to a high resolution model (main scene).*

Before you begin, you must ensure that the components of the each model (the one in the reference scene and the one in the main scene) use the same naming scheme. For example, if you are trying to reference the animation from `low_ResModel` `left_leg` to `high_ResModel`, `high_ResModel` must also have a component named `left_leg`. If you do not have consistent naming across your reference and main files, then a load error will occur when you try to import the animation as a reference.

- 1 Create a new scene.
- 2 Load the low resolution model using file referencing. For example:

```
file -reference -namespace lowResModel "/data/models/low_res_model.ma";
```

Maya automatically assigns a unique reference node, such as `lowResModelRN`, to the model you open using file referencing.

- 3 Animate the model and save the scene.  
This saved scene file is useful if you need to revise the animation at a later time.
- 4 Export the animation for the referenced model in your scene as a Maya ASCII or binary file using the `-exportAnimFromReference` flag with the `file` command.  
For example:

```
file -exportAnimFromReference -referenceNode lowResModelRN "/data/animation/model_animation.ma";
```

The animation on your low resolution model is saved to an animation reference file that is separate from the model's scene file.

- 5 Save your scene, and then create a new scene.

## 4 | Animation

> How do I use these new file command flags?

- 6 Load the high resolution model using file referencing. For example:

```
file -reference -namespace highResModel "/data/models/high_res_model.ma";
```

- 7 Import the animation using file referencing from the low resolution model and swap namespaces as needed. For example:

```
file -reference -swapnamespace lowResModel :highResModel "/data/animation/model_animation.ma";
```

The file command substitutes the namespace prefix `lowResModel:` with `:highResModel:`. For more information on swapping namespaces, see “-sns/swapNamespace” on page 180.

- Note
- A colon (:) is required to specify the full namespace path in the model’s file. If a full namespace path is not specified, the namespace is interpreted relative to the current namespace. See `:highResModel` in the above example.
  - You can specify only one `-namespace` flag per file command. This ensures a one-to-one mapping between the model and animation.

For this example, the animation reference file may contain the following:

```
createNode animCurveTA -name "leftArm_rotateZ";  
setAttr -size 3 ".ktv[0:2]" 1 -100.5 120 45.4 217 99.8;  
connectAttr "leftArm_rotateZ.o" "lowResModel:leftArm.rz";
```

## **4 | Animation**

> Example MEL procedure for customizing the color of multiple animation curves

### **Example MEL procedure for customizing the color of multiple animation curves**

See the Animation chapter of the online What's New in Maya 6 guide in Maya Help. See also "Customize animation curve colors" on page 175.



# 5

# Character Setup

## Retargeting animation

### What is animation retargeting?

In Maya 6 you can now retarget animation data from the joints of one skeleton (source) to the joints of another skeleton (target). The source skeleton is the skeleton *from* which you want to retarget its animation data, and the target skeleton is the skeleton *to* which you want to retarget the source's animation.

Retargeting is useful when you want to transfer animation between skeletons that have the same or different proportions.

### Retargeting workflow

- Set a neutral pose for your source and target skeletons.  
See "How do I set my skeleton's neutral pose?" on page 186.
- Label the joints of your source and target skeletons.  
See "How do I label my skeleton's joints?" on page 187.
- Set the retargeting solver options.  
See "Retargeting > Retarget Skeleton" on page 195.
- Perform the retarget.  
See "How do I retarget animation from one skeleton to another?" on page 192.

---

**Note** If you encounter an error, see "Retargeting error messages" in the Skeletons chapter of the Character Setup guide.

---

## 5 | Character Setup

> How do I set my skeleton's neutral pose?

### How do I set my skeleton's neutral pose?

#### To set a neutral pose

- 1 Position your character into the pose you want as its neutral pose.

The neutral pose maintains the distinct characteristics of your source and target skeletons. Since the neutral pose lets you differentiate your skeletons when retargeting animation, the pose you set for your character must be distinct.

- 2 Select the root of your skeleton.
- 3 Select Skeleton > Set Neutral Pose.

Your character's current pose is set as its neutral pose and the `retargetPose` tab appears on the root joint's node. See "Retargeting > Set Neutral Pose" on page 193.

## 5 | Character Setup

> How do I label my skeleton's joints?

### How do I label my skeleton's joints?

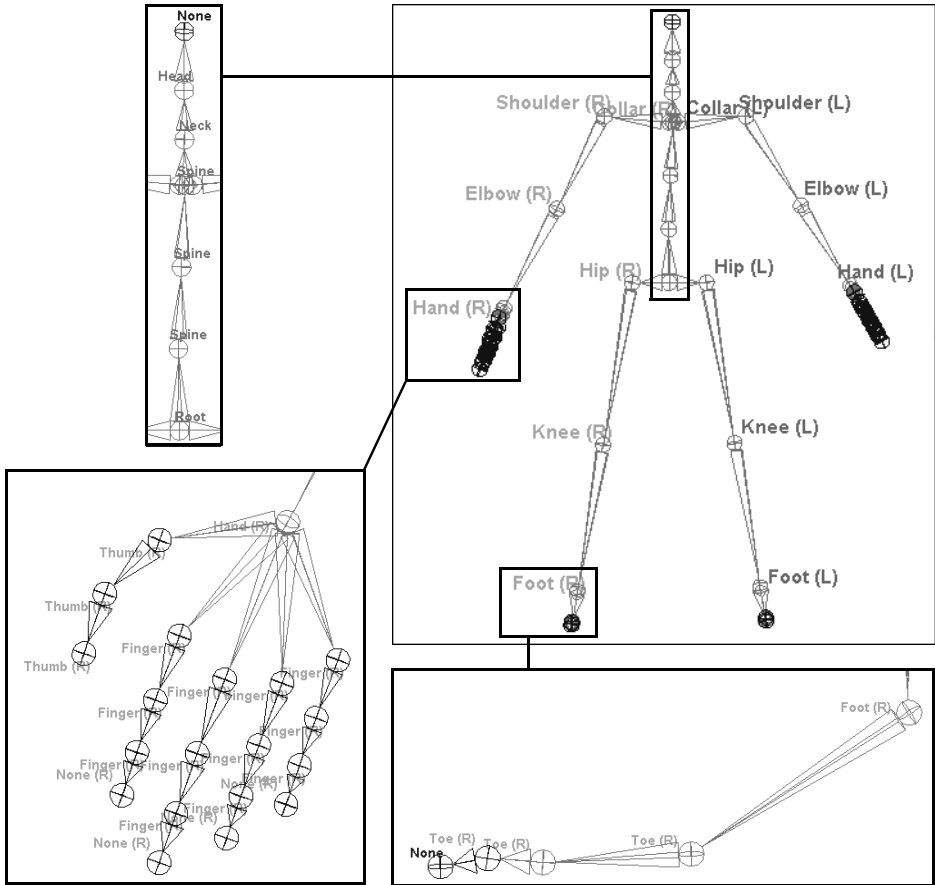

There are three ways in which you can label the joints of your skeleton:

## 5 | Character Setup

> How do I label my skeleton's joints?

- Use the Skeleton > Retargeting > Joint Labelling menu to automatically label each joint in a selected joint chain. See "To automatically label the joints of your skeleton's limbs" on page 188.
- Use the Skeleton > Retargeting > Joint Labelling menu to label each individual joint in your skeleton. See "To label your character's joints using the Joint Labelling menu" on page 189.
- Select a joint and edit its label from the Attribute Editor. See "To set or adjust individual joint labels from the Attribute Editor" on page 190.

**Note**

- If you want to retarget an arm or a leg, then you must label the three primary joints for those limbs on both the Source and the Target skeletons. For the arm, the three primary joints are: shoulder, elbow, and hand. For the leg, the three primary joints are: hip, knee, and foot.
- As you label your joints, each label appears beside their respective joints in the scene view. If you do not see the joint labels in the scene view, see "How do I turn the visibility of my joint labels on and off?" on page 191.

### To automatically label the joints of your skeleton's limbs

For the limbs of your source and target skeletons, do the following:

- 1** Select Skeleton > Retargeting > Show All Labels.  
Joints labels will now appear in the scene view. See "Retargeting > Show All Labels" on page 194.
- 2** Select Skeleton > Retargeting > Joint Labelling.

## 5 | Character Setup

> How do I label my skeleton's joints?

The Joint Labelling menu appears. See "Retargeting > Joint Labelling" on page 193.

- 3 Tear-off the Joint Labelling menu.
- 4 In the scene view, select the parent or top joint of each limb (joint chain) in your skeleton and do the following:
  - Click a side label (Center, Left, Right) in the Joint Labelling menu.
  - Click a type label (Arm or Leg) in the Joint Labelling menu.

Each joint, from the selected parent down its joint chain's hierarchy, is automatically labeled according to their positions in their respective joint chain.

For example, if you select the left shoulder joint of a skeleton and click Left and then Arm in the Joint Labelling menu, then that joint will be labelled as Shoulder(L), the next joint in the chain will be automatically labeled as Elbow(L), and the next joint will be labeled as Hand(L) and so on.

---

**Note** For arms, the forearm joint is labelled as an elbow joint.  
For legs, the ankle joint is labelled as a foot joint.

---

- 5 If you want to adjust or change the labels of your joints, see "To label your character's joints using the Joint Labelling menu" on page 189 or "To set or adjust individual joint labels from the Attribute Editor" on page 190.

### **To label your character's joints using the Joint Labelling menu**

For your source and target skeletons, do the following:

- 1 Select Skeleton > Retargeting > Show All Labels.

## 5 | Character Setup

> How do I label my skeleton's joints?

Joints labels will now appear in the scene view. See "Retargeting > Show All Labels" on page 194.

**2** Select Skeleton > Retargeting > Joint Labelling.

The Joint Labelling menu appears. See "Retargeting > Joint Labelling" on page 193.

**3** Tear-off the Joint Labelling menu.

**4** In the scene view, select a joint and do the following:

- Click a side label (Center, Left, Right) in the Joint Labelling menu. Joint types such as Head or Spine do not require a type label.
- Click a type label (Shoulder, Hip, Head, Spine and so on) in the Joint Labelling menu.

The side and type labels appear beside the current joint. For example, if you selected Right as the side label and Knee as the type label, then the label Knee(R) will appear beside the joint in the scene view.

**5** Repeat step 4 for the rest of the joints you want to label.

### **To set or adjust individual joint labels from the Attribute Editor**

**1** Select the joint in your source or target skeleton whose labeling you want to change and open the Attribute Editor.

**2** In the Joint section of your joint node's tab, expand Joint Mapping.

The Side and Type drop-down menus appear.

**3** Set or change the joint's Side and Type labels as desired.

> How do I turn the visibility of my joint labels on and off?

### How do I turn the visibility of my joint labels on and off?

There are three ways in which you can turn the visibility of joint labels in the scene view on and off:

- Use the Display > Component Display > Joint Labels or Skeleton > Retargeting > Toggle Selected Labels to turn the visibility of joint labels on and off in the scene view for selected joints.
- Use Skeleton > Retargeting > Show All Labels and Skeleton > Retargeting > Hide All Labels to turn the visibility of all joint labels on or off in your scene view.
- Set the visibility of a single joint's label from the Attribute Editor. To turn the display of a single joint's label on or off in the scene view, select the joint, open the Attribute Editor, and turn Draw Label in the Joint Labelling section on or off.

### How do I remove the labels from my joints?

- 1** Select the joint you want to unlabel.
- 2** Select Skeleton > Retargeting > Joint Labelling.  
The Joint Labelling menu appears.
- 3** Select None.  
The current joint's label is removed and is replaced with None.

## 5 | Character Setup

> How do I retarget animation from one skeleton to another?

# How do I retarget animation from one skeleton to another?

**Note** When your skeletons have an IK, FK, and an IK/FK skeleton, then choose just one of the types of skeletons on which to perform the retarget. For example, *source* FK skeleton > *target* FK skeleton.

### To retarget animation from one skeleton to another

- 1** Set the neutral poses for your source and target skeletons.  
See "How do I set my skeleton's neutral pose?" on page 186.
- 2** Make sure that all your source and target skeleton's joints are labeled properly.  
See "How do I label my skeleton's joints?" on page 187.
- 3** Select the root of the source character, and then Shift-click the root of the target character to include it in your selection.  
The first root you select is considered the source, and the second root you select is considered the target.
- 4** Select Skeleton > Retargeting > Retarget Skeleton > .  
The Retarget Skeleton Options window appears. See "Retargeting > Retarget Skeleton" on page 195.
- 5** Set the Neutral Pose, Lower Body, Upper Body, and Time options as desired.
- 6** Click Retarget.

The animation on the source skeleton is retargeted to the target skeleton.



> How do I retarget animation from one skeleton to another?

### **Skeleton >**

#### **Retargeting > Set Neutral Pose**

Sets the current skeleton's pose as its neutral pose. The neutral pose is the common pose you want both the source and target skeletons to be in when retargeting animation data.

The neutral pose maintains the distinct characteristics of your source and target skeletons. This lets you differentiate your skeletons when retargeting animation. For example, if you are retargeting animation from an android to a hunchbacked character, the neutral pose prevents the android character's stiff back from overriding the hunchback's slouch.

See "How do I set my skeleton's neutral pose?" on page 186.

#### **Retargeting > Go to Neutral Pose**

Makes the current skeleton assume its predefined neutral pose. If the skeleton you want to perform this operation on does not have a neutral pose, then an error message appears.

**Note** Skeletons that have neutral poses have a `retargetPose` tab on their root joint's node in the Attribute Editor.

#### **Retargeting > Joint Labelling**

The new Joint Labelling menu lets you assign standard, consistent labels to the joints of your source and target skeletons.

Assigning consistent labels to your source and target skeletons is required to properly retarget animation from one skeleton to another.

## 5 | Character Setup

> Related topics

### Related topics

- ❖ "How do I label my skeleton's joints?" on page 187
- ❖ "How do I turn the visibility of my joint labels on and off?" on page 191
- ❖ "How do I retarget animation from one skeleton to another?" on page 192

### Retargeting > Toggle Selected Labels

Shows or hides the joint labels in the scene view for the selected joints.

### Retargeting > Show All Labels

Shows all joint labels in the scene view.

### Retargeting > Hide All Labels

Hides all joint labels in the scene view.

### Retargeting > Rename Joints From Labels

Changes the current joint's name to its joint label. For example, if a joint is named *joint2* and its label is *Shoulder(L)*, then the joint's name would change to *LeftShoulder*.

### Retargeting > Label Based On Joint Names

Changes the current joint's label to its joint name. For example, if a joint is labeled as *Shoulder(L)* and its joint name is *Right\_Hip*, then the joint's label would change to *Hip(R)*.

## Retargeting > Retarget Skeleton

### Retargeting > Retarget Skeleton > □

The Retarget Options window lets you set the retargeting solver's options.

The retargeting solver is what looks at the animation on the source skeleton's joints and retargets them to the corresponding, labelled joints of the target skeleton.

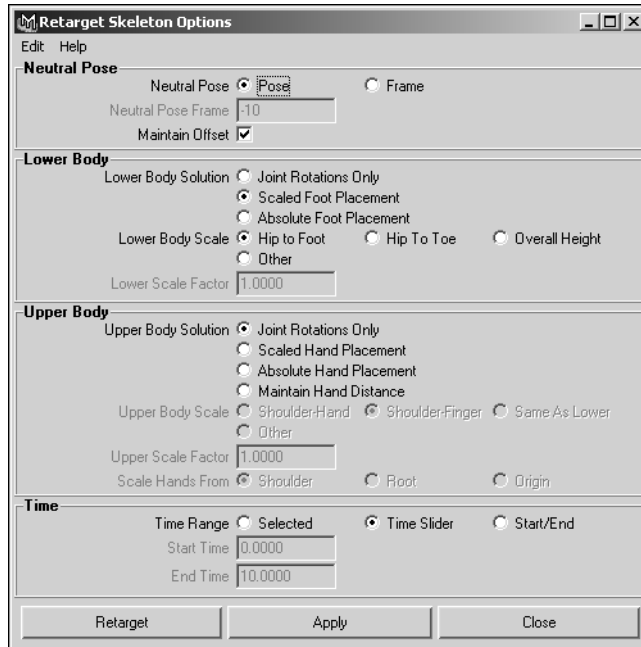

## 5 | Character Setup

### > Neutral Pose

## Neutral Pose

Specifies whether a defined neutral pose (the pose set with Skeleton > Set Neutral Pose) will be used to relate the source and target skeletons during the retarget or whether it will be a pose at a specified frame. See "Skeleton >" on page 193.

### Neutral Pose

Pose	Sets the neutral pose as the pose you set with Skeleton > Set Neutral Pose. If you have already set a neutral pose for each skeleton using Set Neutral Pose, use this option. Pose is on by default.
Frame	Sets the poses of the source and target skeletons at the specified frame as their neutral poses. Use this option if you have not previously set the neutral poses for your skeletons using Skeleton > Set Neutral Pose.

### Neutral Pose Frame

Specifies the frame to use to set the neutral poses of the source and target skeletons.

### Maintain Offset

Maintains the source and target skeleton's global positions so that the target skeleton does not move to the position of the source skeleton when you retarget.

## Lower Body

### Lower Body Solution

Lets you choose how the lower body animation of the source skeleton is retargeted to the lower part of the target skeleton.

### Joint Rotation Only

When on, only joint rotations are retargeted. Use this option if you are mapping animation between rigs that have the same bone lengths. For example, if you are retargeting animation from a low resolution rig to a high resolution rig of the same skeleton.

### Scaled Foot Placement

When on, all animation data is retargeted. Use this option if you are retargeting motion from one skeleton to a completely different skeleton. For example, retargeting animation from a giant to a dwarf.

This option takes into account the position and orientation of the source's feet, and solves the retarget by translating/orienting the target's feet like the source's feet. This ensures that the target skeleton's foot placement looks natural and that its feet move in relation to its proportions-not those of the source skeleton. This option is on by default.

### Absolute Foot Placement

When on, ensures that the target skeleton's feet land at the same points as those of the source. Use this option when you need the target skeleton's feet to land at very specific locations. For example, you would use this if you are retargeting a fight sequence or dance routine.

## 5 | Character Setup

### > Upper Body

#### Lower Body Scale

Specifies how the animation on the hip, knee, ankle, foot, and toe joints of the source skeleton is retargeted to the corresponding leg joints of the target skeleton.

For example, if you are retargeting animation from a giant to a dwarf, you should select the Hip to Foot option because it best handles the retargeting of animation between skeletons whose legs have different bone lengths.

Only available when Scaled Foot Placement is on.

Hip to Foot	Calculates the lower body scale for target using the source's hip to foot scale.
Hip to Toe	Calculates the lower body scale for the target using the source's hip to toe scale.
Overall Height	Calculates the lower body scale for the target using the overall height of the source.
Other	Calculates the lower body scale for the target using the current Lower Scale Factor value.
Lower Scale Factor	Lets you specify a custom scale factor for the target's lower-body animation. Only available when Other is on.

#### Upper Body

##### Upper Body Solution

Lets you choose how the upper body animation of the source skeleton is retargeted to the upper part of the target skeleton.

### Joint Rotation Only

When on, only joint rotations are retargeted. Use this option if you are mapping animation between rigs that have the same bone lengths. For example, if you are retargeting animation from a low resolution rig to a high resolution rig of the same skeleton.

### Scaled Hand Placement

When on, all animation data is retargeted. Use this option if you are retargeting motion from one skeleton to a completely different skeleton. For example, retargeting animation from a giant to a dwarf.

This option takes into account the position and orientation of the source's hands, and solves the retarget by orienting and positioning the target's hands like the source's hands. This ensures that the target skeleton's hand placement looks natural and that its hands move in relation to its proportions-not those of the source skeleton. This option is on by default.

### Absolute Hand Placement

When on, ensures that the target skeleton's hands move to the exact same points as those of the source. Use this option when you need the target skeleton's hands to move to very specific positions. For example, you would use this if you are retargeting a fight sequence or dance routine.

## 5 | Character Setup

### > Upper Body

Maintain  
Hand  
Distance

Maintains the distance between the hands and the rest of the body for the target skeleton. Use this option when the source and target skeletons are carrying objects. For example, basketball players holding balls, waiters holding trays and so on.

### Upper Body Scale

Specifies how the animation on the shoulder, elbow, wrist, hand, and finger joints of the source skeleton is retargeted to the corresponding arm joints of the target skeleton.

Only available when Scaled Hand Placement is on.

Shoulder-  
Hand

Calculates the upper body scale for the target using the source's shoulder to hand scale.

Shoulder-  
Wrist

Calculates the upper body scale for the target using the source's shoulder to wrist scale.

Follow Lower

Calculates the upper body scale for the target using the lower body scale of the source.

Other

Calculates the upper body scale for the target using the current Upper Scale Factor value.

Upper Scale  
Factor

Lets you specify a custom scale factor for the target's upper-body animation. Only available when Other is on.



Scale Hand  
From

Specifies what pivot is used in the calculations for scaling the target skeleton's hands in respect to the source skeleton's hands. Shoulder is selected by default.

Only available when Scale Hand Placement is on.

## Time

Time Range

**Warning** Any animation on the target skeleton within the specified time range will be overwritten by the source skeleton's animation data.

Selected Time  
Range

Sets the retargeting time range to the range of time selected (using Shift-drag) in the time slider.

Time Slider

Sets the retargeting time range to the Time Slider's current range.

Start/End

Sets the retargeting time range to the specified Start Time and End Time.

## General character setup improvements

### Delete all non-skin history

With the new Delete Non-Skin History option, you can now delete the history from your geometry and still retain all its smooth bind skin history.

## 5 | Character Setup

### > Rigid bind allows binding to zero-weighted joints

Use this option to clean up a skin's history after you have edited the UVs or topology of your skinned geometry. Deleting all non-skin history improves interactive performance in Maya and simplifies the history node list for export to game engines.

#### **To delete all non-skin history from your geometry**

- 1 Select *all* the geometry that is bound to your character's skeleton.

**Warning** Delete Non-Skin History looks at *all* your skeleton's input connections. If all the geometry that is bound to the skeleton is not selected when you select Skin > Edit Smooth Bind > Delete Non-Skin History, then the Delete Non-Skin History *will not* evaluate properly.

- 2 If your character is not already at its bind pose, select Skin > Go to Bind Pose.  
Delete Non-Skin History should always be performed at the character's bind pose, otherwise an error may occur.
- 3 Select Skin > Edit Smooth Skin > Delete Non-Skin History.  
All the geometry's history is deleted except for its smooth bind skin history.

## Rigid bind allows binding to zero-weighted joints

The new *Force All* option lets you bind all selected joints, including those with 0 influence, to a specified geometry. You can select Force All from the Bind To drop-down menu in the Rigid Bind Skin Options window.

To open this window, select Skin > Bind Skin > Rigid Bind > . For more information on rigid binding geometry, see “Rigid Skinning” in the Skinning chapter of the Character Setup guide.

## Soft bind skinning affects normals

You can use the new Vertex Normal Edit Tool to edit user-defined vertex normals so that they are affected by skinning. For more information, see “Vertex Normal Edit Tool” on page 82.

## Improvements to the Component Editor

### Improved performance

Now when you view and edit the weight values of vertices from a complicated character rig, the Component Editor displays and updates the bound skin data more quickly.

### New options and layouts for smooth skinning

For more information, see “Component Editor” on page 27.

#### Hide Zero Columns

When this item is turned on, all joint or vertex columns whose weight values are zero are hidden.

#### Show Selected Objects

When this item is turned on, only the vertices that are influenced by the selected joint are displayed.

## Deform > Soft Modification

The new soft modification deformer lets you manipulate groups of vertices at a time to modify the surface of a target geometry. For more information, see “Soft Modification Tool and Deformer” on page 59.

## 5 | Character Setup

### > Deform points outside the lattice

## Deform points outside the lattice

You can now specify the range of influence that lattice deformers have on their target object's points. The new Outside Points Transform options let you transform all an object's points, even when parts of the object are outside of the lattice. Also, these options let you specify a falloff distance in which object points continue to be deformed by the lattice when they are outside of the deformer.

Transforming object points outside of the lattice is useful when you want to maintain a normal lattice deformation for objects that randomly pop outside of the lattice. For example, maintaining lattice deformations when chaining lattices together. The Only If Inside Lattice option is on by default.

The Outside Points Transform options are located in the Create Lattice Options window. To open the lattice deformer options window, select Deform > Create Lattice > . For more information on lattice deformers, see "Lattice deformer" in the Deformers chapter of the *Character Setup* guide.

### Outside Points Transform

Specifies the extent to which the lattice deformer affects its target objects points.

Only If Inside  
Lattice

Only points within the base lattice are deformed.

Transform All  
Points

All the target object's points—inside and outside the lattice—are deformed by the lattice.

Transform If  
Within Falloff

Points within the base lattice and up to the specified falloff distance are deformed by the lattice. For example, if you set the Falloff

## 5 | Character Setup

### > Sculpt deform with texture map

Distance to 2.0, then points within the base lattice and up to 2 widths of the lattice are deformed.

#### Falloff Distance

Specifies the distance from the base lattice up to which points are affected by the lattice deformer. The units of falloff distance are measured in lattice widths. For example, a Falloff Distance value of 3.0 sets the falloff distance to 3 lattice widths.

The falloff degrades linearly from the edge of the base lattice to the specified falloff distance. This option is available only when Transform If Within Falloff is on.

## Sculpt deform with texture map

You can now use 2-dimensional textures to control the strength of the deformation field that surrounds the sculpt object. This lets you deform geometry in a non-uniform manner.

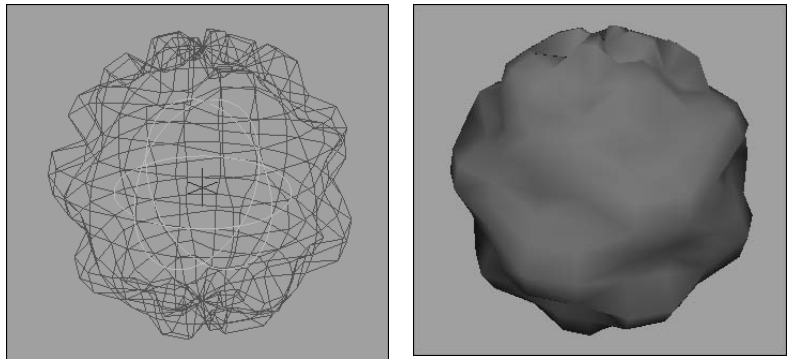

## 5 | Character Setup

> How do I control a Sculpt deformer's strength using a texture?

### How do I control a Sculpt deformer's strength using a texture?

#### **To use a two dimensional texture with the Sculpt deformer**

- 1** Select the object that you want to deform.
- 2** Create a sculpt deformer for that object.  
See "Set sculpt deformers".
- 3** Select the sculpt deformer and open the Attribute Editor.
- 4** Select the sculpt node's tab and expand its Sculpt History section.
- 5** Click the Add Advanced Sculpt Attributes button.  
The Advanced Sculpt Attributes appear in the Sculpt History section.
- 6** Turn on Enable Advanced.
- 7** Click the map button next to the Texture attribute. See "Texture" on page 207.  
The Create Render Node window appears. See "Create > Create Render Node" in the Shading guide.
- 8** Click the 2D texture that you want to use with your sculpt deformer.  
The strength of your sculpt deformer is now affected by the texture.
- 9** Set the advanced sculpt attributes.  
See "Advanced Sculpt Deformer Attributes".

## Advanced Sculpt Deformer Attributes

### Enable Advanced

When on, the Advanced Sculpt Deformer Attributes are active. When off, the Advanced Sculpt Deformer Attributes are inactive.

### Texture

Lets you set a 2D texture to drive the strength of the sculpt deformer. The texture coordinates are assigned to the sculpt object in the same manner as a similarly oriented NURBS object.

### Texture Multiplier

Sets the strength of the 2D texture's influence on the deformation.

### Non Uniform

When on, Maya normalizes the sculpt deformation. Turn on this attribute if you want to compensate for any non-uniform scaling that may have been applied to the target object or the sculpt deformer.

### Paint Resolution

If you want to use Paint Sculpt Map to paint deformation strengths for the sculpt deformer, then you can use these fields to set the resolution values for the file texture.

To change the resolution, you must first disconnect the existing file texture, change the resolution setting, and then re-click the Paint Sculpt Map button.

## 5 | Character Setup

> Restrict the direction of a surface's jiggle

### Visualize Texture

When on, the objects influenced by the deformer are displayed in wireframe, and the deformer itself is displayed in textured mode. This lets you see the texture that is being used, and is useful when painting deformation textures.

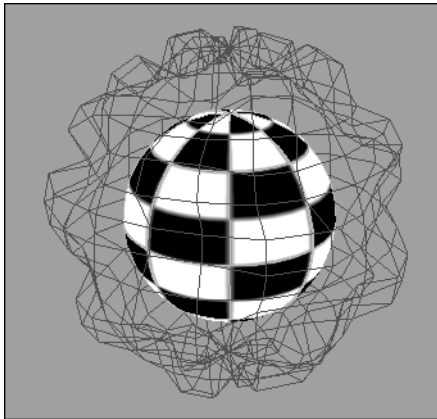

### Paint Sculpt Map

Opens the 3D Paint Tool for you to paint deformation strengths over the surface of the deformer. Also, Paint Sculpt Map creates a new file texture and connects it to the sculpt deformer's Texture attribute. If a non-file texture is connected to the deformer, clicking this button disconnects it.

For more information, see "Texturing > 3D Paint Tool" in the Paint Effects, Artisan, and 3D Paint guide.

## Restrict the direction of a surface's jiggle

With the Jiggle deformer's new Direction Bias attribute, you can control the direction of a surface's jiggle relative to the direction of its normals. A Direction Bias of 1.000 causes a jiggle deformed surface to move only in the direction of its normals and a



## 5 | Character Setup

### > Restrict the direction of a surface's jiggle

Direction Bias of -1.000 causes a jiggle deformed surface to move only in the opposite direction of its normals. A Direction Bias of 0.000 causes the jiggle deformed surface to move in both directions. The default Direction Bias value is 0.000.

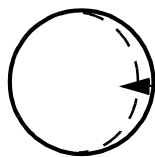
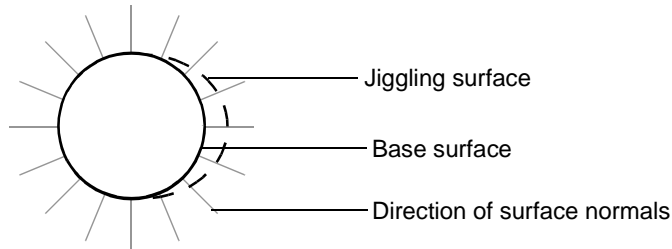

Direction Bias -1.000

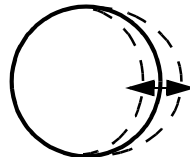

Direction Bias 0.000

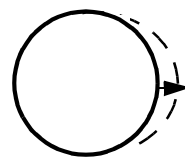

Direction Bias 1.000

You can use the Direction Bias attribute to prevent any unwanted collapsing of a jiggle deformed surface. For example, if you are animating the jiggly stomach of a sumo wrestler, you can set the Direction Bias attribute's value to 1.000 so that the surface of the character's stomach will only jiggle outward.

For more information on the Jiggle deformer, see "Jiggle deformers" in the Deformers chapter of the Character Setup guide.

## 5 | Character Setup

> Create a Cluster for each CV on a curve

### Create a Cluster for each CV on a curve

You can now create a cluster deformer for each CV on a curve by selecting **Edit Curves > Selection > Cluster Curve** from the Modeling menu set. This is useful for manipulating Spline IK curves. For more information, see "Curve/CV Selection" on page 96.

# 6

# Dynamics

## Deforming particles

Previously, deformers could only affect objects whose structure was defined by control points. In Maya 6, most deformers can now affect the behavior of particles. Deformers let you influence particle positions in a variety of ways.

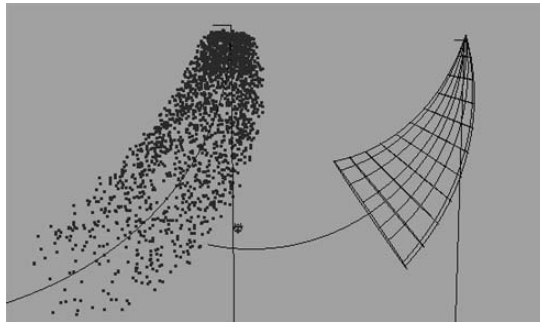

A bend deformer applied to particles (left) and geometry (right)

### To deform particles

- 1 Create a scene with particles.
- 2 Select the particle object.
- 3 In the Animation menu set, click Deform.
- 4 Select the deformer you want to use on the selected particle object. You can deform particles with all deformers except for the skinning and blend shapes deformers.

The deformers operate in the same way as they do for geometry. You can also layer deformers.

## 6 | Dynamics

### > Per-particle field attributes

You can also combine particle deformation with forces: deform the particles, then apply the desired forces to the intermediate object. Alternatively, you could apply forces to particles before the application of a deformer.

**Note** Particles affected by deformers do not exhibit inertia. Attributes such as velocity are not affected by deformations of particle shapes, and should be accounted for when animating particles using deformers.

For example, particles within a flow deformed with a bend deformer will not slow down or speed up in relation to their position within the bend.

## Per-particle field attributes

You can now manipulate field attributes on a per-particle level. This functionality works for the case where `particleShape` is used as the source of the field, as well as the case where the `particleShape` is affected by a field. In the case where the attribute is affected by both, the value from the `particleShape` acting as the source of the field will take precedence.

If the `particleShape` is acting as the source of the field, this feature allows each field to behave its own way. If the `particleShape` is simply affected by a field, this feature allows each particle to be affected by a unique set of field attributes.

### To apply per-particle field attributes

- 1 Apply a field to a set of particles.
- 2 In the `particleShape` Attribute Editor, expand the Add Dynamic Attributes section, if necessary.

> Per-particle goalU/goalV attributes for poly goal objects

- 3** Click the General button. The Add Attribute dialog box is displayed.
- 4** Create a per-particle attribute of float or vector type on the particleShape with the name *fieldName\_attributeLongNameOnTheField* or *fieldName\_attributeShortNameOnTheField*. The type for the per-particle attribute you use must match the attribute type on the field.  
  
For example, create airField1\_magnitude to control the magnitude on airField1.
- 5** Write an expression to control this attribute.
- 6** In the field's Attribute Editor, go to the Special Effects tab, and turn on Apply Per Vertex.

## Per-particle goalU/goalV attributes for poly goal objects

Previously, goalU/goalV values were only respected for NURBS goal objects, and polymesh goal objects could only attract particles to their mesh vertices. In Maya 6, per-particle goalU/goalV attributes apply to polymesh goal objects, letting you specify particular points on the goal mesh surface to which particles will be attracted. Animation of goalU/goalV values, as well as the goal object and its UV coordinates, is fully supported.

The following figure shows the Attribute Editor for polymesh goal objects. For each polymesh object, a UV Set control has been added to let you decide which UV set to use when determining the goal position of a particle given its goalU/goalV values.

## 6 | Dynamics

> Per-particle goalU/goalV attributes for poly goal objects

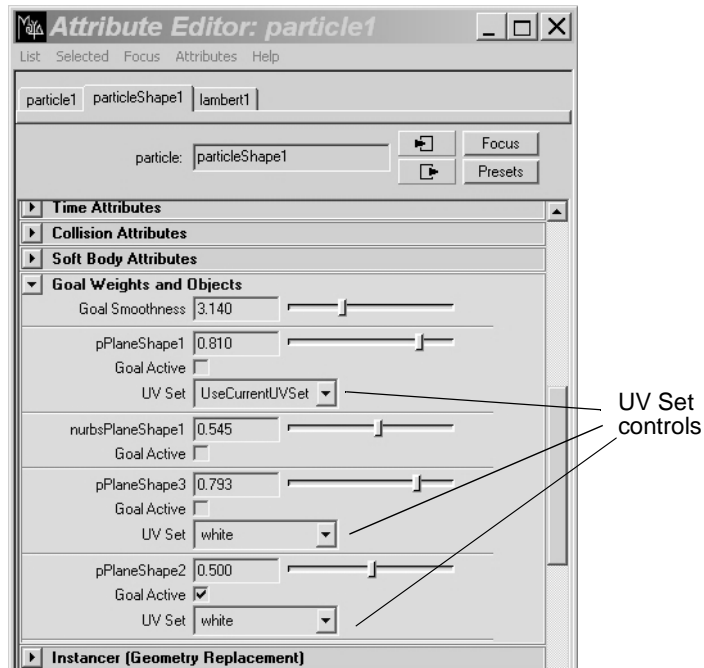

Since UV mappings on polymesh objects are arbitrary, it is possible that a given goalU/goalV pair may map to more than one point on the goal surface. If there are multiple potential goal points for a particle, Maya selects the point that is closest to the particle's current position in world space, and uses that as the goal position. This decision is recomputed at every frame, so if the particle moves closer to one of the other potential goal positions, the particle will be attracted to that goal position instead of the original goal position.

Similarly, it is also possible that no point on the object matches the specified goalU/goalV values for a particular particle. In that case, the mesh vertex that is closest in UV space to the specified goal point is used. This decision is updated at every frame.

**Note** For polymesh goal objects, if a particle's goalU/goalV values are not present on the goal surface (that is, they are unmapped), the particle is attracted to the vertex nearest to the specified values. This may lead to the particle hopping between vertices of the mesh if the goal UV values are animated through unmapped space.

## Expression applied before and after dynamics

In Maya 6, runtime expressions can now be evaluated before, after, or both before *and* after dynamics calculations.

The Runtime before Dynamics, Runtime after Dynamics, and Creation options located in the Particle section of the Expression Editor is where you specify when the expression you create is executed. To create runtime expressions that are evaluated both before and after dynamics, create a Runtime before Dynamics and a Runtime after Dynamics expression.

Scene files and scripts created with a previous version of Maya will still produce the same results.

## 6 | Dynamics

### > Multiple random number streams for particles

## Multiple random number streams for particles

In Maya 6, support for multiple random number streams has been added to the MEL language. Streams can be created, deleted, selected, and queried. This functionality lets you control the generation of a specific set of random numbers and ensure that they are repeatable.

For example, you can now create different repeatable random number streams for different expressions in the same scene. This will let you avoid having to use the same random number stream for the entire scene.

For more information, see "Multiple random number streams" on page 357.

## Textured surface emission for poly surface emitters

In Maya 6, polymesh surface emitters can now take advantage of the texture-based tools that were previously only available to NURBS surface emitters. Animation of the poly emitter and its UV coordinates are fully supported.

The existing controls behave exactly as they do for NURBS surface emitters. One additional control has been added to let you select the UV set on the poly emitter that is used for textured emission effects. The same UV set is used for all textures attached to all textured emission effects (color/opacity and emission rate). If the UseCurrentUVSet option is selected, then the active UV set on the surface emitter is used.



In addition, the Need Parent UV control now also applies to polymesh surface emitters. When this flag is enabled, emitter particles will have their parentU/parentV attributes set to the (U,V) values of the points at which they were emitted, relative to the selected emitter UV set.

**Note** For the textured surface emission controls, full UV-linking of the attached textures is not supported. All attached textures (for emitted color, opacity, and emission rate) perform their lookups in the same UV set, namely the one specified in the new UV Set dropdown in the Texture Emission Attributes section of the emitter's Attribute Editor.

## Ability to disable script output on particle events

In previous versions of Maya, specifying a particle collision callback would first echo the collision callback command to the Script Editor before executing it whenever a particle collision occurred. In scenes containing thousands of particles, this could slow down playback and unnecessarily clutter the Script Editor output. In Maya 6, we have added the ability to disable script output on particle events.

The Echo Collision Commands option in the Maya preferences will allow you to enable or disable this behavior. It is checked (enabled) by default.

### **To enable/disable script output on particle events**

- 1** Select Window > Settings/Preferences > Preferences.  
The Maya Preferences window appears.
- 2** Click Dynamics under Settings to open the Dynamics Preferences.

## 6 | Dynamics

### > Solvers > Interactive Playback

- 3** Do one of the following:
  - Turn off the Echo Collision Commands to disable script output on particle events.
  - Turn on the Echo Collision Commands to enable script output on particle events.
- 4** Do one of the following:
  - Click Save to save all changes to the Dynamics Preferences. The Maya Preferences window remains open.
  - Click Cancel to disregard any changes to the Dynamics Preferences. The Maya Preferences window closes.

## Solvers > Interactive Playback

The Interactive Playback mode lets you interact with dynamic objects and see the simulation update as you playback. For example, you can shake an object with jiggle applied to it to view the effect immediately.

This playback mode can now be started by selecting Solvers > Interactive Playback in the Dynamics menu set, or by typing `play-record` in the Script Editor.

---

**Note** When using Interactive Playback, playback looping is disabled.

---

## Parenting hinge constraints

In Maya 6, a hinge constraint parented to another object now behaves as expected after the parent is rotated.

# 7

# Rendering

## General rendering

### Adobe Photoshop file support

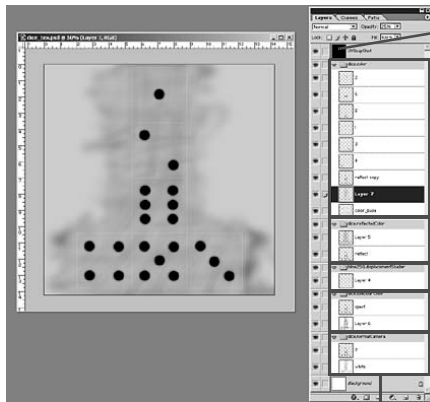

UV snapshots help you paint accurately

Paint layers in layer sets in Photoshop

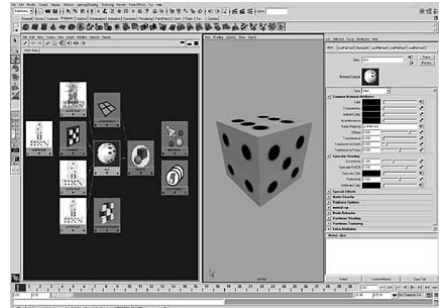

...and see them in Maya

(For Maya Software, Maya Hardware, and mental ray renderers.)

Photoshop files (version 6.0+) are now supported, facilitating simple painting workflows in the following ways:

- You can use any existing Photoshop file as a texture in Maya, anywhere you would normally apply a texture.

## 7 | Rendering

### > Use PSD files in Maya

- You can convert a PSD file with layer sets to a Layered Texture in Maya to help visualize and work with the individual layer sets.
- You can create a layered PSD file from within Maya in order to paint multiple channels (color, bump, specular, etc.) separately on an object, in Adobe Photoshop.
- You can use Maya's 3D Paint Tool to sketch out ("lipstick") an object to act as guidelines for the areas on the Photoshop image that should be painted, useful when UVs are inappropriate or unavailable to be used as a guideline.
- At anytime, you can modify a PSD file in Photoshop, then update (refresh) the image in Maya to see the modifications immediately.

### Use PSD files in Maya

The PSD File node lets you use a PSD file as a texture in Maya. It is similar to Maya's File texture node, but it's for PSD files only.



By default, Maya links a PSD file to the composite image, which is included in the PSD file. Maya can only read image and vector layers, so when the PSD node is linked to Photoshop's composite image (it is by default), Maya supports anything that Photoshop supports, including (for example) layer styles, adjustment layers, text, and so on.

However, you can choose to link the PSD node to a layer set instead, in which case layer styles and adjustment layers are not supported and should be rasterized before the PSD file is read in Maya.

### The advantage of PSD files with layer sets

PSD files with layer sets facilitate iterative painting:

- Photoshop artists can add, modify, or delete any number of layers within a layer set while maintaining the connections in Maya (see also “Create a PSD file with layer sets from within Maya” on page 222).
- Maya artists can convert a PSD node to a Layered Texture, and see the layer sets as multiple PSD File Textures connected to a layered texture in Hypershade.

**Note** Maya treats all layers within a layer set as a single flattened image.

### To use an existing PSD file in Maya

- 1** In Hypershade, load your PSD image file with the new PSD File Texture node (Create Maya Nodes > 2D textures > PSD File Texture).

The PSD file is linked to Photoshop’s composite image.

- 2** If the file has multiple mask channels, you can choose which one to see. Select the mask from the Alpha to Use attribute in the Attribute Editor.
- 3** If the PSD file has layer sets, you can choose a layer set to link to. Select the layer from the Link to LayerSet attribute in the Attribute Editor.
- 4** As with any File Texture in Maya, you can set any PSD File Texture attributes.

## 7 | Rendering

> Create a PSD file with layer sets from within Maya

See "PSD File Texture attributes" on page 226.

### **To convert an existing Photoshop File Texture with layer sets to a Layered Texture**

- 1** In Hypershade, do one of the following:
  - Right-click a PSD File Texture, then select Convert to Layered Texture.
  - Select Edit > Convert PSD to Layered Network.
- 2** To see the multiple layer sets connected to the layered texture, regraph the layered texture.

### **Create a PSD file with layer sets from within Maya**

When you create a PSD file from within Maya, you select the channels to be painted in Photoshop.

These channels are then represented in Photoshop as layer sets, and you can add, edit, or delete any layer within a layer set (see also "Use PSD files in Maya" on page 220). Any changes you make in Photoshop are piped back into the appropriate channels in Maya when you update the PSD node (see "Update PSD textures" on page 225).

## 7 | Rendering

> Create a PSD file with layer sets from within Maya

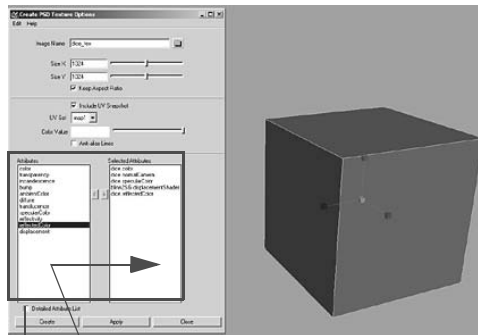

Channels you select from the first column and add to the second column become layer sets in Photoshop.

For a detailed (advanced) list of attributes, turn on Detailed Attribute List.

**Note** An optional UV snapshot works as a guideline to help you paint the texture with greater accuracy. You can create a UV snapshot when you create a layered PSD file in Maya (see "To create and use a layered PSD file in Maya" on page 223).

### To create and use a layered PSD file in Maya

Make sure UVs fit within the 0 to 1 texture space (see the online documentation for details) and select the required material (like Phong, for example).

- 1 Select the object you want to paint.
- 2 Select Texturing > Create PSD Texture.  
The Create PSD Texture window opens.
- 3 Type the name of the Photoshop file to be created, and set any of the options (or use the default).

## 7 | Rendering

### > Sketch out guidelines (“lipstick”) for paint application

For information on the options, see “Create PSD Texture window” on page 226.

- 4** In the list of Attributes, double-click an attribute you want to paint to add it to the list of Attributes. Repeat for additional attributes you want to include. If you want to paint an attribute not shown in the list, turn on the Detailed Attribute List.
- 5** Select Create.

An empty PSD file is created by Maya with layer sets for the selected attributes you want to paint. The background colors are taken from the material.
- 6** Locate the PSD file in the sourceimages directory of your project.
- 7** Open the file in Photoshop.
  - Each attribute to be painted is represented by a layer set, and you can add or delete as many layers as you want within a given layer set. Maya treats each layer set as a separate flattened image, and the material’s base color is used.
  - If you opted to include a UV snapshot, it is inserted on the topmost layer as reference for painting. (This layer does not contribute to the render.)
- 8** Paint the layers in Photoshop, then save the file.
- 9** In Maya, select Texturing > Update PSD Textures.

Each of the PSD image file’s layer sets are represented by a separate node attached to the PSD file node.

### Sketch out guidelines (“lipstick”) for paint application

You can use Maya’s 3D Paint Tool to initially sketch out (“lipstick”) where paint should be applied to an object. Painters can then paint more strategically in Photoshop because they can



easily see where to apply the paint. This works especially well for models with UVs that don't give you enough information to paint effectively.

---

**Note** You can also start by mapping file textures (rather than using the 3D Paint Tool).

---

### **To lipstick a model**

- 1** Roughly paint what you want to see (for example, eyes, mouth, beard) on the model with Maya's 3D paint Tool (see *"The paint tools"* on page 17 in the Maya Help for details), then save the scene.
- 2** Follow the steps to create and use a PSD File texture. See *"Create a PSD file with layer sets from within Maya"* on page 222.

The painted textures are inserted as the base layer in each layer set.

---

**Note** Once you have created the PSD, you cannot go back to 3D Paint for those attributes.

---

## **Update PSD textures**

When you modify a PSD file (in Photoshop) that is connected to a Maya PSD node (in Maya), you can update (refresh) the image in Maya to show the modifications immediately.

### **To update a PSD texture in Maya**

- Select Texturing > Update PSD textures. All PSD textures in the scene are updated.

## 7 | Rendering

### > PSD File Texture attributes

## PSD File Texture attributes

Most of the PSD File Texture attributes are the same as Maya's File Texture Node; see *"File" on page 167* in Shading guide for details.

### Disable File Load

For more information, see *"Disable the initial load of a file texture image" on page 245*.

### Use Image Sequence

See *"Improved ability to use image sequences" on page 245*.

## Create PSD Texture window

### Image Name

Type the name of the Photoshop file you will be painting. By default, Maya uses the scene name and model name.

### Size X

Sets the horizontal resolution in pixels.

### Size Y

Sets the vertical resolution in pixels.

### Keep Aspect Ratio

Constrains the proportions of the X and Y resolution. That is, if you move the X slider, the Y slider moves an equal distance.

### Include UV Snapshot

Creates a UV snapshot as a guideline to help you paint with a greater degree of accuracy in Photoshop.

### UV Set

Specifies which UV Set to use for the UV Snapshot.

### Color Value

Specifies the color to be used for the UV mesh in the snapshot image.

### Anti-alias Lines

Specifies whether or not the lines forming the UV mesh in the snapshot image are anti-aliased. Anti-aliased lines appear smoother, but extend over more than one pixel with varying opacity.

### Attributes, Selected Attributes

Choose from this list of default Attributes for the material. (If you want more advanced options, turn on Detailed Attribute List.)

Selected attributes in the Selected Attributes list represent the channels to be painted. When you open the PSD file in Photoshop, each attributes listed here appears as a layer set.

The following table shows the default available channels that correspond to the layer sets that are created when you create the PSD file.

	<b>Lambert</b>	<b>Blinn</b>	<b>Phong</b>	<b>Phong E</b>
Color	x	x	x	x
Transparency	x	x	x	x
Ambient Color	x	x	x	x
Incandescence	x	x	x	x
Bump Map (Normal Camera)	x	x	x	x

## 7 | Rendering

### > High quality interactive shading

	<b>Lambert</b>	<b>Blinn</b>	<b>Phong</b>	<b>Phong E</b>
Displacement	x	x	x	x
Diffuse	x	x	x	x
Translucence	x	x	x	x
Specular Color		x	x	x
Reflectivity		x	x	x
Reflected Color		x	x	x
Eccentricity		x		
Specular Rolloff		x		
Roughness				x
Highlight size				x
Whiteness				x
Cosine Power			x	

#### Detailed Attribute List

Shows a more detailed list of advanced options you can paint.

## High quality interactive shading

You can now see high quality representations of your work in the scene views as you build and modify (shade, texture, and light) your scenes. High quality shading uses the same technology that produces hardware renders almost instantly in Render View or for batch rendering.

When high quality interactive shading is turned on, the scene views are drawn in high quality by the hardware renderer. This lets you see a very good representation of the look of the final render without having to software render the scene.

The following is not supported:

- motion blur
- software multi sampling

## Turn on High Quality shading

**Tip** If you require faster playback or camera tumbling while using Maya's High Quality shading, turn on Interactive Shading (Shading > Interactive Shading).

### To turn on high quality shading

- 1** Make sure smooth shading (or higher) is on (press 5, 6 or 7).
- 2** In the desired scene view, select Shading > High Quality Rendering.

## Hardware renderer Display options

### Display Quality

#### Low Quality Lighting

Low quality lighting is essentially per-vertex lighting, which calculates light only on vertices, then blends the results. Renders are faster and of reasonably good quality.

#### Match Viewport Lights

When turned on, only as many lights as are supported by the graphics card (typically 8) are used.

## 7 | Rendering

### > Hardware renderer Display options

#### Transparency sorting

The method by which sorting is performed prior to rendering to improve transparency.

**Per object**      Transparent objects are sorted and drawn from furthest to closest in distance. This option provides faster results but may not render complex transparent objects correctly.

**Per polygon**    Each object's polygons are sorted and drawn from furthest to closest in distance from the viewer. This option provides more accurate transparency representation but may take longer to process.

#### Transparent Shadow Maps

Those regions of an object which are fully transparent will not cast a shadow. For example if you map the transparency channel of a shader (on an object) to a checker texture the fully transparent portions of the object would not cast a shadow.

#### Display Parameters

##### Occlusion Culling

This option improves performance for scenes with many objects, where one or more objects can be obscured from the viewpoint of the active camera. When turned on, this option increases performance by preventing out-of-view objects from being drawn.

##### Culling Override

Every position on a surface has a normal which points in the direction that is considered (for culling purposes) to be the "front side" of the surface.

- Single sided means the surface is illuminated by a light if that normal is visible from the light.
- Double sided means that the surface is illuminated on the front and the back sides.

#### Color Texture Resolution

If hardware rendering cannot process a shading network on board the graphics hardware, the shading network is evaluated and converted to a file texture (2D image) that the hardware renderer can use.

This option specifies the dimension of the resulting texture. Affected channels are color, incandescence, ambient, reflected color, and transparency. The default value is 128, which means that any baked color images will have a dimension of 128 by 128 pixels.

#### Bump Texture Resolution

If hardware rendering cannot directly process a shading network on board the graphics hardware, the shading network is evaluated and converted to a file texture (2D image) that the hardware renderer can use.

This option specifies the dimension of the resulting texture. The default value for this option is 256, which means that any baked bump images will have a dimension of 256 by 256 pixels.

### Interactive Shading Mode improvements

Two new options have been added to the new interactive shading options window.

The options in this function drop the display mode down to a level (based on selected options), letting you choose the mode that best matches the speed with which you want to refresh the screen while interacting with the scene (for example, tumbling). As

## 7 | Rendering

> Shading (Panel menu) > Interactive Shading >

always, faster refresh rates mean objects are drawn with less fidelity; however, lower fidelity levels let you work faster while interacting with objects.

**Note** Though the interactive shading options have moved to the new interactive shading option window, the Wireframe, Bounding Box and Points options still behave the same way they did in previous versions of Maya.

### To use and set option for Interactive Shading Mode

- 1** In a panel, select Shading > Interactive Shading > . The Interactive Shading Option box appears.
- 2** Set the options. See "Shading (Panel menu) > Interactive Shading > " on page 232.

### Shading (Panel menu) > Interactive Shading >

#### Interactive shading mode

When High Quality Rendering is turned on, this option smooth shades the display of objects using the standard quality hardware renderer.

#### High Quality Rendering

When High Quality Rendering is turned on, this option shades objects using the hardware renderer, but you can set the following options to quicken the refresh while interacting:



#### Small Object Culling

Enables occlusion culling, determined by a value you specify for the size of an object (or the unobstructed portion of it), relevant to the screen size (in percentage or pixel values). Any object that falls below this level is not drawn.

Example: If an object occupies 5000 pixels out of a viewport which shows 10000 pixels, then a tolerance of 50% would make the object fall below tolerance and therefore not be drawn.

#### Disable Shadows

During interaction no shadows are drawn.

#### Backface Culling

During interaction, all polygon faces that face away from the viewer are not drawn.

## Hypershade performance improvements

The time required to open Hypershade or to switch between tabs within Hypershade has been significantly reduced.

For very large scenes, some types of Hypershade Scene Tabs may still take some time to refresh the first time they are activated. Subsequent activations of the tab take only a few seconds to refresh.

## 7 | Rendering

> Organize render nodes with Hypershade sorting bins

### Organize render nodes with Hypershade sorting bins

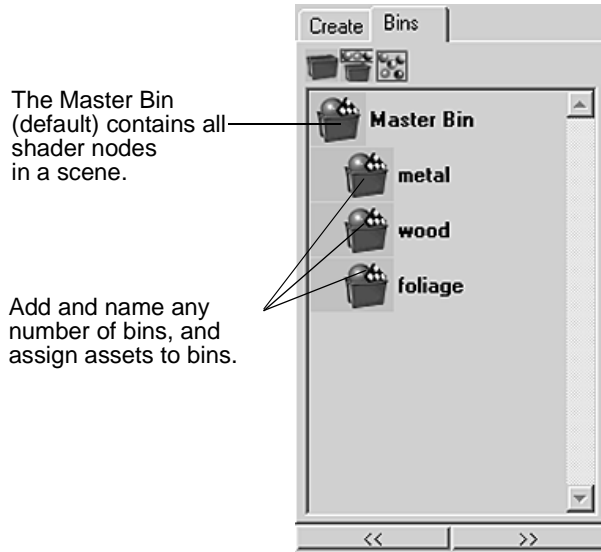

Sorting bins, which are containers for shading nodes (materials, textures, etc.), have been added to Hypershade to help you organize and track shading nodes in your scenes.

A default Master bin contains all shading nodes in your scene. You can add any number of additional bins to a scene and assign nodes to one or more of those bins. By strategically naming the bins, (for example, wood, metal, doors, foliage), you can quickly and more easily locate shading assets to work with them.

### > Organize render nodes with Hypershade sorting bins

- Notes
- When a node is assigned to a bin, all the shading nodes upstream to this node are also assigned to this bin.
  - The Hypershade asset tabs (Materials, Textures, etc.) exist for all sorting bins, allowing for further organization and filtering.
  - While shading nodes can be assigned to more than one bin, they are not duplicated in the scene.

#### **To select (see the contents of) bins**

When you select one or more bins, you can see the contents of the bins.

- To select and see the contents of one bin, click the bin.
- To select multiple bins, do one of the following:
  - Shift+click a range of bins.
  - Ctrl+click each bin you want to select.
- Ctrl+click a bin to toggle between selecting and deselecting it.

#### **To create a new empty bin**

- 1** In the Hypershade Bins tab, click the Create Empty bin button. The New Bin Name window appears.
- 2** Type the new name, then click OK. A new empty bin appears.

#### **To create a new bin with selected content**

- 1** Select the assets you want to add to a bin.
- 2** In the Hypershade Bins tab, click the Create bin from selected button.

## 7 | Rendering

> Organize render nodes with Hypershade sorting bins

### To rename a bin

- 1 In Hypershade, right-click the bin.
- 2 Select Rename.

### To duplicate a bin

- 1 In Hypershade, right-click the bin.
- 2 Select Duplicate. The bin is duplicated and all the same assets are assigned to it.

### To select assets

- To select one asset, click the asset.
- To select multiple assets, do one of the following:
  - Marquee drag across the assets.
  - Shift+click to switch between selecting and deselecting an asset.
- To select assets that are not assigned to a bin, in the Hypershade Bins tab, click the Select unsorted content button.

### To add assets to a bin

In Hypershade, do one of the following:

- Select the assets you want to add to a bin, then right-click bin and select Add Selected.
- Select the assets you want to add a bin, then middle-drag them to the bin.
- To add a single asset to a bin, drag it to the bin.

### To make assets exclusive to one bin

This procedure removes selected assets from all other bins.

- 1 In the Work Area, select the assets you want to make exclusive to one bin.

- 2 Right-click any existing bin.
- 3 Select Make Selected Exclusive.

**To remove some assets from a bin**

- 1 Select the assets you want to remove from a bin.
- 2 Right-click the bin.
- 3 Select Remove Selected.

**To remove all assets from a bin**

- Right-click the bin, then select Empty.

## New menu item in Hypershade

The following menu item lets you highlight all the node swatches from selected object:

Edit > Select Materials from Object All

If you want to know which materials are used by objects A,B,C, you can first select objects A,B,C, then select this menu item to select materials related to A,B,C.

Objects A,B,C will no longer be selected. The initial objects you selected can be a normal object or a group or faces of a polygon geometry.

## Node filtering improvements in Hypershade

Every scene tab (also called an Asset tab) in Hypershade has new controls for filtering the nodes displayed in the tab (similar to the ones in HyperGraph).

## 7 | Rendering

### > Node filtering improvements in Hypershade

By default, each scene tab has an implicit filter that is determined by the tab type specified when the tab was created (or by the default tabs when the scene was first created). The tab only displays nodes that pass this filter, and you cannot disable this filter. For example, a Materials tab shows only material nodes.

However, you can now filter the nodes in a tab by name (in the text box) or by type (with the Show button).

At any given time, one or more of these filters can apply to each scene tab. Only nodes that pass all of the applied filters are displayed. You can clear filters at any time.

#### Clear button

Click to clear any applied filters (beyond the implicit one) and return the tab to its default contents.

#### The text box

Lets you type in a character string, which can be a regular expression, to specify by name the nodes to be shown. Only nodes whose name matches the character string are displayed in the tab.

#### Show button

Shows a menu from which you can select the types of nodes to be shown.

**Objects** Choose which object types to show. Select Clear Below to turn off all filters.

**Invert Shown** Reverse the filters so visible objects are invisible and invisible objects are visible.

**Show All** Turns off all filters in the Show menu.

**Show selected types** Shows only object types of the same type as the current selection.

**> New (and support for custom) tabs in Hypershade**

Create Entry	Lets you save the current filter with a name.
Delete Entry	Lets you delete a saved filter.
Show Auxiliary nodes	Shows node types that are normally not shown because they are rarely needed (such as underworld nodes).
Auxiliary nodes	Lets you set what nodes are considered "auxiliary".

## New (and support for custom) tabs in Hypershade

You can now create several new types of scene tabs (Tabs > Create New Tab) in Hypershade to better organize, view, and select render nodes.

The new filtering controls (see "Node filtering improvements in Hypershade" on page 237) work for any new tab you create.

- The All Nodes tab shows every node in your scene. It provides a quick way for you to get an overview of all nodes in your scene.

## 7 | Rendering

### > Hide shape and transform nodes in Hypershade

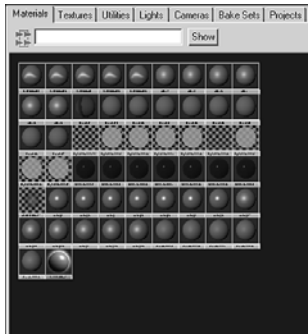

- The All mental ray Nodes tab shows all mental ray for Maya base shader nodes (and any custom shaders) in the scene. It provides a quick way for you to get an overview of all mental ray for Maya nodes in your scene.
- The rest of the new tab types display specific categories of mental ray for Maya base shader nodes (and any custom shaders). (The Apply flag on the mental ray for Maya base shader (or integrated custom shader declarations) determine which of these categories each node falls into.)

## Hide shape and transform nodes in Hypershade

Hypershade automatically displays all shape and transform nodes that are connected to various types of shading nodes (Shading Engine, Switch nodes, for example).

Often, you want to view only those shapes and transforms that influence a shading network and not those that happen to be in the Shading Group to express set membership.

You can now suppress the display of shapes and transforms in Hypershade to simplify a cluttered Work Area or to reduce the amount of time it takes for Hypershade to refresh.



#### **To control the display of shapes and transforms**

- 1** In Hypershade, select Options > Display (Work Area Only), then specify the options.
- 2** Regraph to see the change.

#### **No Shapes**

No shapes are displayed in Hypershade.

#### **All Shapes except Shading Group members**

Only shapes that are directly connected to shading nodes are shown. Shapes that are only connected to the Shading Group are not shown.

#### **All Shapes**

All shapes are displayed, including ones that are connected to the Shading Group only for the purpose of expressing set membership.

#### **Transforms**

Transforms are shown.

The display of transform nodes in Hypershade is controlled by the "Transforms" flag in the object's Attribute editor.

## 7 | Rendering

> Test textures (and texture ranges)

### Test textures (and texture ranges)

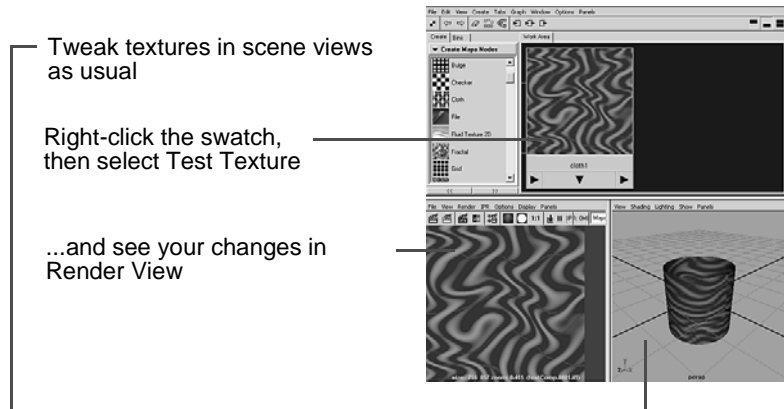

Available on Windows and Mac OS X.

Though most swatches in Hypershade and the Attribute Editor update automatically to show your changes as you build shading networks, you can now create a full image (or range of images), at various resolutions, on any node in a shading network.

You can use this sample image to see the results of portions of a shading network texture or to verify the look of a texture that doesn't have a visual interactive representation (such as Multiply Divide or Gamma Correct utilities).

You can also perform simple compositing within Maya by connecting several File node outputs to a layered texture and setting the desired attributes. For example, you can composite hardware rendered particles over software rendered scenes.

### Limitations and conditions

- Utility node's output must be connected to something downstream to see a sample from it.

- Texture testing supports the native Maya rendering nodes.
- The tested texture always overwrites the same image using the same file name (but you can save it to a different name) from Render View.

#### **To test a texture on any native Maya rendering node**

**1** In Hypershade, do one of the following:

- Right-click a render node, then select Test Texture.
- Select the texture, then select Edit > Test Texture.
- If you want to change the resolution first, select the texture, then select Edit > Test Texture >  to display the options.

A sample image is rendered in Render View.

**2** To save the tested image, in Render View, select File > Save As.

#### **To test a range of images on any native Maya render node**

- Do one of the following:
  - Select the texture, then select Edit > Render Texture Range.
  - If you want to change the resolution, file format, frame range or padding, select the texture, then select Edit > Test Texture Range >  to display the options.

The rendered range of images is automatically loaded and played back in FCheck.

Edit (Hypershade) > Test Texture >

x/y resolution

The x and y resolutions in the tested texture.

## 7 | Rendering

> Limitations and conditions

Edit (Hypershade) > Render Texture Range >

### Image name

The name of the resulting rendered images. Images are written to the images directory of the active project. The file name will be padded (for example, checker.0001.iff).

### File Format

The file format of the rendered texture images.

### x/y Resolution

The x and y resolutions for the rendered texture images.

### Start Frame

The first frame number used for the sequence.

### End Frame

The last frame number used for the sequence.

### By Frame

The number of frames to advance between the Start and End frames (see *"Render Global Settings window"* on page 165 in the Rendering guide for details).

### Padding

The number of padding digits in the number (for example, 001 is 3, 0001 is 4, and so on).

### Fcheck

Launches and loads the newly created sequence into fCheck.

## Disable the initial load of a file texture image

To load scenes faster, you can now disable the initial loading of file texture images on a per-node basis from disk.

### **To disable the initial loading of a file texture image**

- 1** Select the file texture.
- 2** In the File Attributes section of the Attribute Editor, turn on Disable File Load.

**Note** Turning on `disableFileTexture` off after the file has been read does not "unload" the texture.

### Disable File Load

Turn this attribute on to prevent the file associated with the File Texture node from loading.

## Improved ability to use image sequences

You can now more easily use image sequences with image planes and File textures. Previous workflow included having to set keys (for animation) or write expressions. Maya automates this for you now, and can recognize any of the various possible file formats.

### **To use an image sequence with an image plane or File Texture**

- 1** Create an image plane or File texture, using any of the usual methods.  
See "Create, edit, or position an image plane" on page 265 or "Map a 2D or 3D texture" on page 76 of the Shading guide for instructions

## 7 | Rendering

### > New image plane and File texture attributes

- 2 Turn on Use Image Sequence.
- 3 This automatically enters an expression (=frame) into the Image Number attribute. The Image Number is equal to the Timeline's current frame.

#### To add file formats

Find the `getFileSequenceFormats.mel` file in the `Maya6.0\Scripts\Others` folder.

## New image plane and File texture attributes

### Use Image Sequence

If off (default), the image plane used is the single image file indicated by Image Name (the file name and extension).

If on, the image loaded corresponds to an image from the sequence selected, determined by the Image Number.

### Image Number

If Use Image Sequence is on, the default expression of “=frame” is used to synchronize the image sequence with the Timeline.

In other words, at frame 1 the image with a numeric value of 1 in it will be loaded. At frame 24, the image with a numeric value of 24 in it will be loaded.

By modifying the default expression (or removing it and setting keys) for Image Number, you specify alternate timeline to image sequence number relations. For example, setting a key frame of the last image at the beginning of the timeline and the first image at the end of the timeline will result in reversing the sequence.

## Frame Offset

If Use Image Sequence is on, the default Frame Offset is set to 0, which means that the image sequence numeric value corresponds exactly to the timeline frame number. If an offset between these values is needed, enter the desired offset in frames. For example, if the image sequence numeric value starts at 100 but the animation starts at frame 1, enter a value of 100 to compensate. Negative offset values are also supported.

**Note** As a result of these new attributes, the following attributes have become obsolete and are removed from the UI:

- Use Frame Extension
- Frame Extension

## New command line render utility

There is now a new rendering command-line utility called `Render`.

- To get quick renderer-specific information, type:

```
Render -r rendername -help
```

where `rendername` is the name of the renderer:

- `mr` = mental ray
- `sw` = software renderer
- `hw` = hardware renderer
- `vr` = vector renderer

## 7 | Rendering

### > New color utility nodes

All flags appear with a brief description. Each flag corresponds to the appropriate section of the Render Globals Settings Window (see *"Render Global Settings window"* on page 165 in the Rendering guide)

- To get general information, type:

```
Render -help
```

---

**Note** The previous command-line render utility has been renamed to `mayaSWrender` and is no longer recommended.

---

## Maya software rendering

### New color utility nodes

For software rendering only.

You can now more precisely define how an input value (value, point, color) remaps to a new output value. Three new color utility nodes have gradient attributes that give you far greater control over remapping than what Ramp textures provide.

With these new utility nodes, you can (for example):

- remap and control color values and alpha values separately
- perform simple color correction
- affect the translation of objects
- finetune or totally change the hue, saturation, and luminance of a color



**Tip** Maya's new color utility nodes work well with the new test range feature. See "Test textures (and texture ranges)" on page 242.

### **To use a new color utility**

- 1** In Hypershade, select > create Maya Nodes > Color Utilities.
- 2** Select whichever utility you want to use:
  - See "remapValue utility" on page 250 for a description of this utility and strategic uses.
  - See "remapColor utility" on page 251 for a description of this utility and strategic uses.
  - See "remapHsv utility" on page 251 for a description of this utility and strategic uses.
- 3** In the utility's Attribute Editor, adjust the gradient graphs, and set the Input and Output ranges.

## **Input and Output ranges**

The input attributes index into the gradient controls, which define a new output value. Usually, you connect a varying attribute of some sort (such as values from the sampler info node, texture/shader outColors, or object position) to the input connection.

### **inputMin, inputMax**

Define the values that remap into the left and the right of the gradient controls.

For example, if your input attribute varied between -1 and 1 you can set the inputMin to -1 and the inputMax to 1. This way your minimum values result in the values defined at the

## 7 | Rendering

### > remapValue utility

left of the ramp and the maximum map to the right. Values outside the min/max range will be clipped to the value at the edges of the gradient.

#### outputMin, outputMax

Determine the range of the output attribute. These attributes represent the top (max) and bottom (min) values of the gradients, or (in the case of a color gradient control) the displayed white (max) and black (min) output.

In some cases, you may want the outputMin/Max to match the inputMin/Max. For example if you are remapping the cameraNormalY to object color using a remapValue node, because the camera normal varies between -1 and 1, the inputMin/Max would be set to these values. However we do not want black to be -1,-1,-1, so it would make sense for the outputMin/Max to be 0 to 1.

#### remapValue utility

Remaps a scalar input to both scalar and color outputs. The scalar output is remapped with a scalar gradient, and the color output is remapped using a color gradient.

You can remap color and alpha values and control each of them separately. So, for example, you can define mappings where the alpha is the inverse of the color, or where they have different ranges.

#### Strategic use (an example)

How you use the remapValue depends on what you want to remap.

For example you can vary reflectivity based on the facingRatio in either of the following ways:

- Connect a samplerInfo facingRatio to the inputValue, and connect the outValue to your shader's reflectivity.

- Connect the outColor to the shader specularColor.

Initially the part of the surface facing the view will be more reflective, but you can reverse this by reversing the gradient (make the value gradient go down to the right, or if you mapped the outColor make the color gradient become darker to the right).

## remapColor utility

Lets you remap a three-channel input (such as RGB color) to another three-channel output with three gradient controls for more precise shading.

You can also use this utility for non-shading purposes, however. For example, you could connect the translate of one object to remapColor.color, then connect remapColor.outColor to the translate of a second object, which effectively maps the position of one object onto the other. In this particular case, the second object initially follows the first then stops outside a zero to 1 bounding box. (To increase the size of this bounding range, increase both the input and output Min/Max settings.) If you reverse the gradients, the second object moves in the opposite direction. And if the graphs are wiggly, the motion of the second object would also be wiggly.

## remapHsv utility

Lets you adjust the color output of nodes. It converts an RGB input to HSV, remaps using separate HSV gradients, then converts the result to a color output.

With this utility, you can fine-tune or completely change the hue, saturation, and luminance of a color with the provided gradients. For example, you could connect the outColor of a file texture to the color (input) attribute on remapHsv, then connect the remapHsv outColor to your shader color. By editing the gradients you could then modify the brightness range or hue of the file texture with a great deal of control:

## 7 | Rendering

### > Imported shading network optimizations

- You can make the image black and white make the saturation graph all zero.
- You can invert the brightness for an x-ray effect make the value graph 1 at the left and zero at the right.

You can also remap the color of a shader by connecting the outColor of the shader into remapHsv.color then connecting remapHsv.outColor the outColor of a surface shader node. The surface shader then becomes a color correctable version of the original shader.

---

**Note** The surface shader performs no calculations directly, it is simply a placeholder for a shading outColor attribute.

---

## Imported shading network optimizations

By default, when you import a file more than once into Maya, the geometry and shading networks are duplicated. These redundant shading networks and reassignment of geometry inflate the scene size and load time, and clutter your working scene.

You can now prevent the duplication of a shading network (unless, of course, you need it) when you import a scene, or you can delete any duplicated network from within your working scene.

### **To prevent redundant shading networks on import**

When you import a scene (File > Import ), turn on Remove Duplicate Shading Networks.

### **To delete a redundant shading network**

In Hypershade, select Edit > Delete Duplicate Shading Networks.

## Maya can now recognize new IMF plug-ins

You can now see IMF plug-ins listed in the following places:

- Hardware Render Globals Settings window
- Image plane (input)
- Render View (input and output)
- File texture (input)

## Transfer surface information

You can now transfer surface characteristics from one surface to a texture map on another. The most common application of this tool is in the creation of high-performance, real-time models where some surface detail cannot be adequately represented within the polygon limit required.

You can create a higher-detail (non-real-time) model that defines the desired details, then transfer the details across onto the real-time model in the form of a map (for example, a normal map).

### To bake a normal map

- 1** Select the source surface, then the target surface.
- 2** Select **Lighting/Shading > Transfer Surface Information >**
- 3** Set any options, then click **Bake and Close**, **Bake**, or **Close**.

For a description of the options, see "Transfer Surface Information Options" on page 254.

## 7 | Rendering

### > Transfer Surface Information Options

## Transfer Surface Information Options

### Target Options

#### Transfer

Selects the information you want to transfer.

**Object space**      Object space normals always point in the same direction, even if the triangle is rotated, so use them for textures on non-animated objects.

**Tangent space normals**      Tangent space normals are defined locally, per vertex, and can be rotated by deformation. They are good for textures on animated objects.

#### Map width

The width of the texture to be created, in pixels.

#### Map height

The height of the texture to be created, in pixels.

#### File name

The filename and location of the texture to be created.

#### File format

The format of the texture to create (for example, .dds, .bmp, .jpg).

#### Target UV Set

The UV set on the target surface for which this texture should be created.

The UV set defines how the target surface is mapped into texture space. For accurate results, the UV mapping must be non-overlapping (that is, you cannot map two different faces on the target surface to the same UV region).

### Shading Network

Controls how the newly created texture is displayed on the object.

Preserve  
current  
shading  
network

Leaves the current network intact, and creates the texture file on the disk; no visible change exists in the scene view.

Attach a color  
channel  
preview  
network

Replaces the current network with a simple shading network that provides a color-only preview of the result on the object itself.

Attach a Cg  
preview  
network

Replaces the current network with a simple hardware shader that displays the actual result of the mapping on the object; this requires the cgfxPlugin to be loaded (see "Improved hardware plug-in shader support" on page 257), otherwise this option is grayed out.

### Algorithm Options

#### Search method

Controls how intersections between the source and target surfaces are selected.

## 7 | Rendering

### > Transfer Surface Information Options

#### Use outermost intersection

Instructs the algorithm to find the furthest intersection from the target surface that is within the search depth.

This option should be selected to capture modeled surface detail such as shoelaces, armor, pockets, etc.

#### Use nearest Intersection

Instructs the algorithm to use the closest point on the source surface, which prevents map artifacts that are caused when neighboring parts of the source surface are projected across gaps in concave surfaces.

Common examples are under arms or between fingers, where the skin on one "side" of a gap is mapped across onto the wrong side. When using the first option (say, to map the effect of shoelaces), these same artifacts can often be removed by selecting appropriate Search Depth values.

#### Search depth

Controls how far away from the target surface to look for intersections on the source surface. For concave models, this value should be set to around half of the minimum distance between parts of this surface which should remain separate (for example, fingers). If you are seeing large areas of the result which do not contain the correct surface information, try increasing this value.



### Overscan Pixel Passes

Controls how many pixels to overscan in order to fill UV mapping seams and prevent blending discontinuities. Each pixel requires an additional pass and will increase the time taken to create the result.

### Texture Fill Pass

When turned on, all “empty” pixels in the final map are smoothly blended from the surrounding pixels to remove UV seam blending artifacts. This occurs after any pixel overscanning.

## **Maya hardware rendering**

### Performance improvements for hardware rendering

Performance-boosting improvements, such as geometry and texture caching, have been made to the Hardware Renderer.

Specific results vary based on the actual graphics card used (refer to online qualification charts for the latest information).

### Improved hardware plug-in shader support

Hardware plug-in shaders are now supported by high quality interactive shading (see “High quality interactive shading” on page 228) and batch hardware rendering.

Use this new feature to visualize user-defined effects, such as color-per-vertex (using the `hwColorPerVertexShader` plug-in) or CgFX shaders (using the `cgfxShader` plug-in). The API is provided

## 7 | Rendering

### > API plug-in development considerations

through a new interface on the MPxHwShaderNode which does not have dependencies on Maya's UI data types. The majority of existing plug-ins are easily portable to the new interface.

Plug-in shaders can take advantage of the following features:

- Shaders are off screen batch hardware renderable.
- Shaders are capable of shadow casting.
- Full support for high quality transparency sorting.
- Full support for mask render output.
- Full support for depth render output.
- Full support for motion blur.
- Full support by high quality multi-sampling.
- Improved draw performance compared to standard shading mode in the 3D views.

### API plug-in development considerations

Most plug-ins can easily be ported to the new interface by implementing `glBind()`, `glUnbind()`, and `glGeometry()`. The bind and unbind methods are slightly different compared to the old interface; they are called only once per frame. These methods should specifically be used to allocate resources, and not to set OpenGL state. The old interface is still used by the interactive 3D view, but does not need to be provided if the new interface has been implemented in the plug-in.

Care must be taken in the allocation and de-allocation of hardware resources (i.e., textures, vertex programs, fragment programs, etc.) because the batch hardware renderer will delete the graphics context at the end of the rendering. Instability will result if the plug-in shader allocates resources for batch, and attempts to re-use them for interactive. In this case it may be desirable to override both `bind()` and `glBind()` to determine in which situation the draw is being done.

### > Color per vertex now supported by hardware renderer

There is currently no obvious way to determine whether the plug-in is being drawn for high quality interactive or batch hardware rendering. As a result on every refresh to the high quality view `glBind()` and `glUnbind()` will be called. The plug-in developer should take care to re-use resources where possible as allocating and de-allocating resources on every refresh will have a significant impact on performance.

## Color per vertex now supported by hardware renderer

The implementation of the colour per vertex (CPV) feature has been changed to take advantage of the hardware renderer. (Using the PlayBlast or the Hardware Render Buffer to render CPV is no longer recommended.)

---

**Note** To see if your specific hardware graphics card supports color per vertex, run the hardware render diagnostics.

---

This feature is available in the new High Quality Interactive Shading mode (see "High quality interactive shading" on page 228) and for the batch hardware renderer. Make sure you are using a supported video card (see the Maya Hardware Renderer Qualification Chart (online) for more information).

As in previous versions of Maya, you can set color per vertex options in:

- the Attribute Editor for a polygonal surface (under the Mesh Component Display section)
- from the Custom Polygon Display Options window (Display > Custom Polygon Display > )

## 7 | Rendering

### > Implementation details

modulate2x, a new material blend for CPV attempts to mimic the texture blend of same name available on games consoles. This blend is available only in the High Quality Rendering mode (see “High quality interactive shading” on page 228) within the scene views and for batch hardware rendering. When High Quality Rendering is not turned on, the previous shaded mode display provides a very rough approximation of the same function. The key difference is that CPV and textures are modulated in High Quality Rendering versus CPV and materials, when not in this mode.

### Implementation details

This new implementation, along with the two new polygon object attributes that come with it, allows for a more accurate interpretation and display of color per vertex in the following ways:

- Color calculations are more accurate now because they are performed in floating point and are not clamped to the frame buffer color range until the end (when writing out the final pixel color).
- The quality of lighting is improved because the hardware renderer provides a more accurate lighting implementation.
- Transparency (alpha) is taken into account only when all material channels on a shader are overridden, or the *color* channel on the shader is affected and the Material Blend is set to Overwrite.

In all other cases the RGB component of CPV is pre multiplied by the CPV alpha before being used.

- When the Alpha Channel (Mask) Output option is turned on for the hardware renderer (in the Hardware Render Globals UI), the alpha channel is written out as part of the output image. This does not affect interactive display. The mask takes into account the CPV alpha values based on the Matte

### > Polygon object attributes (Mesh Component Display section)

Opacity options set for the shader. The alpha channel is taken into consideration only when all of the material channels on a shader are overridden or the Color channel on the shader is affected and the Material Blend is Overwrite.

- The new implementation takes the alpha component of CPV when casting shadows if the Transparent Shadow Maps option is turned on for the hardware renderer (in the Render Globals Settings window) or the Hardware Renderer Display Options option box for the High Quality Shading in interactive viewports.
- CPV display is turned on only when Low Quality Lighting is not turned on for High Quality Rendering mode in viewports (default), or when High Quality Lighting is turned on for batch hardware rendering (default). For low quality lighting and CPV, disable High Quality Rendering use the old CPV display.

### Polygon object attributes (Mesh Component Display section)

#### Display Colors

Choose whether or not to display the internally stored colors on the polygonal geometry. By default these colors are not displayed.

#### Display Color Channel

Indicates which Maya material channel should be affected. The mapping for the new implementation is as follows:

None	CPV overrides all material channels.
Ambient	Maps to the <i>Ambient Color</i> channel on a shader.

## 7 | Rendering

### > New performance-enhancing render globals

(Note that the CPV has a visible effect in the display only if an ambient light illuminates the object.)

Diffuse	Maps to the <i>Color</i> channel on a shader.
Ambient and Diffuse	Maps to both the <i>Ambient Color</i> and <i>Color</i> channels on a shader.
Emission	Maps to the <i>Incandescence</i> channel on a shader.
Specular	Maps to the <i>Specular Color</i> channel on a shader. In cases where a shader does not have this channel, (such as Lambert) the shader will act as if a channel did exist and was affected by CPV. It is recommended that users map the appropriate shader to the object for proper correspondence.

#### Material Blend

CPV values are now blended during lighting and texturing, which gives a more accurate result compared to pre-Maya 6, which was more an approximation.

## New performance-enhancing render globals

### New hardware render global settings

#### Small Object Culling

When this performance-improving option is turned on (default), opaque objects that are smaller than the specified threshold are not drawn.

This option provides the same functionality as the Occlusion Culling option found in High Quality Rendering mode in viewports (see "High quality interactive shading" on page 228)

Culling  
Threshold (%  
of image  
size)

This is the threshold suboption for the Small Object Culling option. The threshold you provide is the percentage of the image size that an object occupies in the output image.

If an object is less than that percentage in size then it is not drawn. Size is measured in pixels in screen space (relative to the camera used for rendering). The default percentage is 0 percent.

This option ignores View > Camera Settings options (such as Gate and Fill options), which are used for image output only.

E.g. % = 10.0. Image size 100 by 100 (pixels). The threshold in pixels would be  $100 \times 100 \times .10 = 1000$  pixels. If an object was less than 1000 pixels in size then it would not be drawn.

E.g. % = 0.0 Image size 100 by 100 (pixels). The threshold in pixels would be  $100 \times 100 \times 0 = 0$  pixels. If an object was less than 0 pixels in size then it would not be drawn. This can occur when one opaque object completely obscures another object with respect to the current camera used for rendering.

## 7 | Rendering

> mental ray shader manager

# mental ray for Maya rendering

## mental ray shader manager

The *Shader Manager* lets you interactively load and unload mental ray shader libraries and work with them during a Maya session. (You no longer need to shut down first, and you no longer need to set the environment variable `MI_CUSTOM_SHADER_PATH`.)

You can select from a list of `.mi` library files that contain the mental ray shader declarations. The shaders contained in the selected `.mi` library files automatically appear in Hypershade, just like the Maya and mental ray for Maya base shader nodes. mental ray for Maya base shaders are now fully integrated into Hypershade and Create Render Node panel.

(You no longer need to set the environment variable `MAYA_MRFM_SHOW_CUSTOM_SHADERS` to show custom shaders in Hypershade.)

**Note** Though you can dynamically load/unload shaders in render time, those shaders that are used should be specified in the `maya.rayrc` file.  
The `maya.rayrc` file requires both `.mi` and/or `.so` of the desired libraries to be included.

### To load or unload custom mental ray shaders

- 1 Select Window > Rendering Editors > mental ray > Shader Manager.

The Shader Manager opens and shows which declaration files are loaded.

- 2 Click to load or unload a declaration file, auto load the file, or get information on the file.



> Window > Rendering Editors > mental ray > Shader Manager

## Window > Rendering Editors > mental ray > Shader Manager

### Auto-load

These buttons show which files have been loaded by means of the MI\_CUSTOM\_SHADER\_PATH mechanism.

### Information button

This button displays a window that shows you which node types have been created from a loaded declaration file.

### Browse button

Opens a File Browser window that allows you to locate and load .mi declaration files not yet listed in the *Shader Manager*.

## Simplified shader connection workflow

You can now work with mental ray for Maya shaders the way you do with Maya render nodes. That is, you can now drag and drop mental ray for Maya shaders in Hypershade to make default connections (or to choose from a list of common connections) to objects. The default connection is based on the type of shader you want to connect.

## IPR rendering with mental ray for Maya

mental ray for Maya now supports Interactive Photorealistic Rendering (IPR).

IPR lets you interactively adjust attribute values and node connections in your scene and instantly see the rendered results in Render View.

## 7 | Rendering

### > Limitations

## Limitations

### Supported while IMR is active:

- any connection change to supported shading nodes, including light and camera shading attributes
- any value change on supported shading nodes, even without stopping renderer if considered safe, including light and camera shading attributes
- any custom mental ray nodes connection/value changes
- any geometry type shading, including particles, fluids, and fur, with some exceptions
- any raytrace shading effect if raytracing is turned on
- global illumination impact on shading nodes (via irradiance)
- contour tuning via object attributes if contours are turned on
- post effects tuning, like shader glow
- render region change
- refresh render whole image
- pause mode
- creating and assigning a new shader through UI
- 'assign new/existing material' or create in Hypershade and drag to the object

### NOT supported while IMR is active:

- Render View: resolution change, render camera change, render options, render globals, any options changes
- Shading nodes: texture nodes (color remap create)
- Materials: material assignment if the material is created outside IMR
- Lights: creation, transformation (orientation, movement, scaling)

> mental ray for Maya command line options

- Cameras: creation, camera view change, transformation
- Geometry: creation, tessellation/approximation change, displacement change
- mental ray features: photon tracing (done before IMR loop), final gather tracing (mostly done before IMR loop)

### mental ray for Maya command line options

The following mental ray for Maya command line options are supported during IPR:

**-rg/region**

Update the IPR region to the selected one.

**-rr/regionRect**

Set a new IPR region explicitly (works together with -region).

**-pt/pauseTuning**

Controls actual rendering of IPR requests, shader changes are always recognized in all cases.

**-q -imr**

Returns true (1) if IPR is active.

## New features and support improvements

### Support for Maya Fluids

You can now render Maya Fluid Effects as volumes or surfaces with mental ray for Maya, and you can use them as 2d or 3d textures. Fluids can also be exported to .mi format for offline, standalone rendering.

For more information, see "Rendering Fur in mental ray" on page 309.

## 7 | Rendering

### > Limitations

### Limitations

- You cannot render the pressure grid.
- Some differences in rendered results may occur.
- Receive shadows in the Render Stat should be turned on to get self shadowing.

### Support for Maya Fur

You can now render Fur in mental ray using the standard Fur workflow.

Fur in mental ray is rendered with hair primitives within the main render pass, rather than as a post process. This allows Fur to show up in reflections and refractions, and through transparent objects.

For more information, see "Rendering Fur in mental ray" on page 309.

### Integrated contour rendering

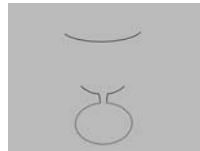
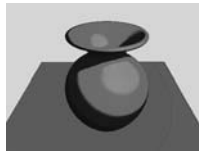

Some examples of simple contour rendering

You can now render simple contour lines for non-photorealistic rendering using the standard shading and lighting workflow.

You can control contour rendering by defining the color and width of lines in the Shading Group and Render Globals.

You can still use the mental ray for Maya base shaders (or any custom shaders) to render more sophisticated contour effects, beyond the standard contour rendering now provided. (See "Custom shaders" on page 275.)

**To render contours**

- 1** In the mental ray tab of the Render Globals Settings window, set the desired contour attributes, then enable contour rendering.

For descriptions of options, see "Contours (Render Global Settings window)" on page 269.

- 2** For the Shading Group node of each object to participate in contour rendering, set the contour attributes.

See "Flag objects to participate in contour rendering (object Shading Group)" on page 275.

---

**Note** If all controls are disabled and all contrasts are 0, contour rendering is disabled.

---

**Contours (Render Global Settings window)**

The following attributes control the location and characteristics of contour line rendering.

**General****Enable Contour Rendering**

Turn on or off (default) contour rendering.

**Hide source**

When turned on, only the contour is visible (that is, the object that causes the contour invisible).

## 7 | Rendering

### > Contours (Render Global Settings window)

#### Flood color

When Hide Source is turned on, this is the colour used to flood or fill the entire frame as the background colour before rendering the contour. In other words, this is the color onto which the contours caused by Hide Source are drawn.

#### Quality

##### Over-Sample

Improves the quality by processing at N times larger than sampling down to the correct size. If this value is set to 2, the contours are processed at twice the resolution, so the quality (anti-aliasing mostly) will be approximately twice as good.

##### Filter Type

The filter type used when downsampling contours to image resolution.

##### Filter Support

The filter support as (fractional) number of pixels.

#### By Property Difference

Options in the detection section let you define the locations at which mental ray for Maya detects and draws contour lines.

#### Around Coverage

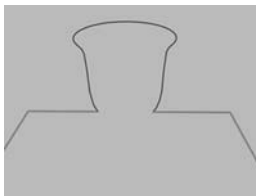

## 7 | Rendering

> Contours (Render Global Settings window)

Draw contour lines based on pixel coverage (where rendering samples detect objects are present) based on a pixel being covered by the object.

### Between Different Primitives

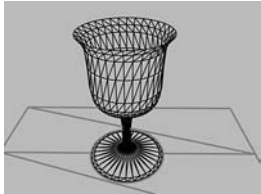

Draw contour lines between different primitives.  
(Enabling this in effect draws tessellations.)

### Between Different Instances



Draw contour lines between different instances.

### Between Different Materials

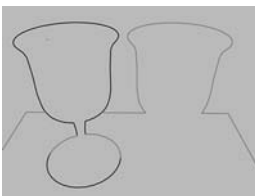

## 7 | Rendering

> Contours (Render Global Settings window)

Draw contour lines between primitives with different materials.

### Between Different Labels

Draw contour lines between different labels (these are not the same as character labels).

### Around Coplanar Faces

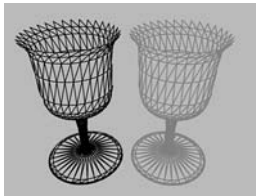

Draw contour lines between different normals.

### Front vs. Backface Contours

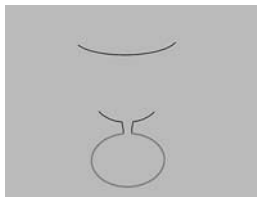

Draw contour lines between, if the sign of the dot product of the normal vector and the view vector differs from one sample to the other.

### By Sample contrast

#### Enable Color contrast

Turns on or off (default) the color contrast setting.



#### Color Contrast

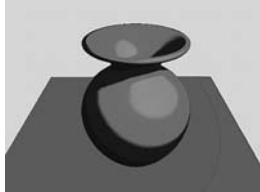

Draw contour lines between pixels that have a color difference that is larger than the set value.

#### Enable Depth contrast

Turns on or off (default) the depth contrast setting.

#### Depth Contrast



Draw contour lines between pixels whose depth difference (in camera space) is larger than the set value.

#### Enable Distance contrast

Turns on or off (default) the distance contrast setting.

## 7 | Rendering

> Contours (Render Global Settings window)

### Distance Contrast

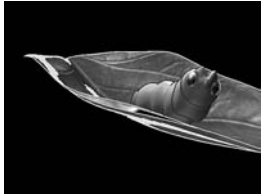

Draw contour lines between pixels whose distance is larger than the set value.

### Enable Normal contrast

Turns on or off (default) the normal contrast setting.

### Normal Contrast



Draw contour lines between pixels whose normal difference is larger than the set value. (Normal difference is measured in degrees.)

### Enable UV contours

Turns on or off (default) the UV contour setting.

> Flag objects to participate in contour rendering (object Shading Group)

### UV Contours

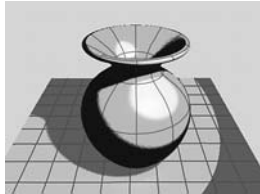

Draw contour at every  $U$ th and  $V$ th isoline of the primary UV space.

### Rendering/Compositing

These controls map to a mental ray for Maya output shader. This shader is respected only if at least one contour detection criterion is triggered (or custom shaders are connected) and Enable Contour Rendering is turned on.

### Custom shaders

You can connect mental ray for Maya base contour store and contrast shaders here. Any shaders connected here override the integrated contour rendering feature.

## Flag objects to participate in contour rendering (object Shading Group)

Each shading group can have individual contour rendering attributes defined. Set the following options to achieve the desired look.

### Enable Contour Shading

Enables contour shading for all objects associated with the shading group.

## 7 | Rendering

### > Render blurry reflections and refractions

#### Color

The color of the contour lines. This attribute can only be a color and cannot have a procedural or texture map connected to it.

#### Alpha

The alpha of the contour lines.

#### Width

The width of the contour lines.

#### Relative Width

If off, *Width* is specified as (fractional) number of pixels. If on, *Width* is specified in percents of the horizontal image resolution thus maintaining the relative contour size if the resolution changes.

## Render blurry reflections and refractions



Blurry reflections

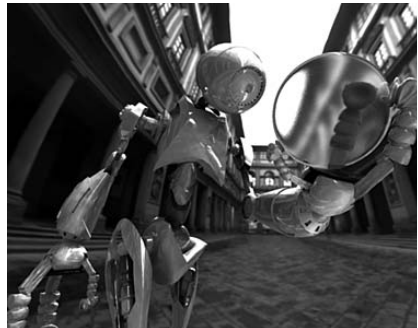

Blurry refractions (magnifying glass)

(Uffizi Light Probe image courtesy of Paul Debevec  
([www.debevec.org/Probes](http://www.debevec.org/Probes)))

Raytraced reflections and refractions are typically rendered perfectly sharp, but in the real world, no perfect mirror or transparency exists. Instead, small-scale impurities reflect or refract light slightly, creating a blurry, glossy look. You can now easily render natural looking blurry reflections and refractions with mental ray for Maya.

**Note** Previous workflow involving mental ray for Maya base shaders is still supported.

### **To render blurry reflections and refractions**

- 1** With mental ray selected as the renderer, turn Raytracing on in the Render Globals Settings window (see *"Render Global Settings window"* on page 165 in the Rendering guide).
- 2** In the mental ray tab of the desired material's Attribute Editor, set the reflection and/or refraction blur attributes.

#### **Reflection/Refraction Blur**

Determines the blurriness of the reflection or refraction by calculating the angle (in degrees) between the perfect reflection or refraction direction and the jittered ray direction. A value of 0 creates a perfectly specular interaction; a value of 90 a perfectly diffuse reflection or refraction. Values of 10 to 30 are good starting points.

#### **Reflection/Refraction Rays**

Specifies how many rays to use to sample the random deviation from the perfect specular direction. (Blurry reflections and refractions require supersampling because a ray's direction is not precisely determined with this feature. It may deviate (randomly) from the perfect specular direction, within the bounds specified by Reflection/Refraction Blur.)

## 7 | Rendering

### > Rendering Image-Based Lighting (sky-like illumination)

In general, more rays are required for more blurry reflections or refractions. Other sampling parameters also affect this setting: per-object samples and the *Render Globals* sample setting supersample in image space. If you increase any of these two settings, you may be able to reduce the number of rays without loss of quality, while significantly improving performance.

#### Irradiance

This is the ability to bounce indirect photons.

#### Irradiance color

This is the color of bounced photons.

## Rendering Image-Based Lighting (sky-like illumination)



#### Image-based lighting

(Uffizi Light Probe image courtesy of Paul Debevec,  
[www.debevec.org/Probes](http://www.debevec.org/Probes).)

You can now simulate light emitted from an infinitely distant (environment) sphere to create image-based lighting more easily and efficiently.

Image Based Lighting is a technique to create photo-realistic images. With image-based lighting, you use an environment texture (an image file) to illuminate the scene. Typically, the image is a photograph of a real environment, either a panoramic image or a photograph produced by taking pictures of a chrome ball (to capture the surrounding environment).

(The existing method, where you had to surround your scene with a real, finite geometrical sphere, is still supported. If a finite distance to the environment is required (for example, for a closed room), you can still do this. However, because the shape is actual geometry, mental ray processes it as such. If it is tessellated, it becomes part of acceleration structures (BSP tree) where it (due to its encompassing nature) can slow rendering down significantly and interactive Maya workflow can be hindered. With the new workflow, no geometry is created (or exported on .mi export); instead, IBL is represented by a set of shaders. You create the desired IBL node, then set its attributes to achieve the look you want.)

## How image-based lighting works

When an IBL node is created one or more of the following mental ray for Maya shaders is used:

### Environment Shader

Along with *Final Gathering* this shader implements classic style image-based lighting. The color of the environment is picked up by final gather rays and incorporated into surface illumination. An environment shader is passive. It doesn't actively contribute to the scene's lighting; instead, it gets sampled only as needed. Best results are achieved if the IBL

## 7 | Rendering

### > How image-based lighting works

texture is diffuse. A specific case would be a texture consisting of a single color; this results in ambient occlusion computation.

#### Photon Emission Shader

Photons are emitted from the IBL environment sphere. These photons pick up their energies (or colors) from the IBL texture. A photon emission shader emits all its photons once per frame. It is more active than an environment shader in this sense. Photons work best with mostly diffuse IBL textures.

#### Light Shader

A low-resolution control texture is computed (from the file or procedural IBL texture) and mapped to the IBL environment sphere. Whenever direct lights are sampled, the light shader is invoked. In this sense, the light shader approach is the most active one, and the most expensive. The IBL environment can be seen as one big area light. This approach works best (also due to importance sampling) if the IBL texture contains sharp features, and preferably contains many more black than non-black pixels.

These three approaches may be combined to achieve specific effects, at the expense of computation time.

#### **To use image-based lighting**

- 1** In the mental ray tab of the Render Globals Settings Window, click the Create button in the IBL section.
- 2** A new IBL node is created, replacing any currently connected node. (Though multiple IBL environments can exist in a scene, only one can be used at a time.)  
A sphere-like tool appears in the scene view, and the IBL node's Attribute Editor automatically pops up.
- 3** Set the IBL node's attributes.



For details, see "IBL node attributes" on page 281.

- 4** Position the IBL node with the sphere-like tool.  
For details, see "Position an IBL texture" on page 281.
- 5** Render with Final Gather or Global Illumination to illuminate the scene.

Final gathering picks up incandescence samples from the environment texture. Illumination models deal with these samples similar to direct light arriving from, for example, a spot light.

---

**Note** IBL environments can be previewed interactively (if they are File texture based).

---

## Position an IBL texture

When you create an IBL node, its shape is represented in the scene view.

Moving (and to a certain extent scaling) the shape has no effect because the environment is considered infinitely distant. For best results, scale the shape as large as your clipping planes permit.

Rotations, however, let you position the texture on the IBL node shaders.

## IBL node attributes

### Image-based Attributes

#### Hardware Filter

Sets texture filter quality for shaded view: nearest or linear.

## 7 | Rendering

### > IBL node attributes

#### Hardware Alpha

Sets transparency of IBL shape locator in shaded view. 0 is transparent, 1 is fully opaque.

#### Color Gain, Color Offset, Invert, Alpha Is Luminance

These attributes are the same as those of Maya's texture node. They apply in similar ways to IBL.

#### Mapping

Select a UV space for the environment sphere: spherical (latitude-longitude) or angular (HDR Shop).

#### Type

Select whether to map a file or a procedural texture as the *IBL texture*. File textures can be previewed interactively. See also Texture.

#### Image Name

If *Type* is set to *File Texture*, name of file on disk.

#### Use Frame Extension

If turned on, the texture's file name may change on a per-frame basis. This is used to load an image sequence instead of a single file.

#### Frame Extension

The frame extension.

#### Texture

If *Type* is set to *Procedural*, connect a 2D texture shading network to this input.

## Visibility

Controls the IBL texture's visibility to certain ray types. This maps to a camera environment shader in mental ray. If all controls are deactivated, then no environment shader is processed. For classical image based lighting, the IBL texture must be visible to final gather rays and *Final Gathering* must be on.

## Light emission

You can emit light from the IBL environment radially inward toward the origin (of world space). If light emission is turned on, the IBL node acts like true light sources in the scene. The IBL texture is mapped to a mental ray light shader just like a real light source would be.

## Emit Light

Turn on, if you want to emit light from the infinitely distant IBL environment.

## Quality U, Quality V

The light shader sets up a “control texture” for light emission. Every pixel in that texture virtually represents a directional light. These values specify the control texture's resolution. Higher values offer more precision but are more processor intensive. Loaded IBL textures are downsampled to the filter resolution; procedural textures are sampled at this resolution in pixel units for optimum performance.

## Samples

Sampling all “directional lights” represented by the control texture is often prohibitively expensive. Therefore the shader has a built-in importance mechanism that attempts to select the primary (key) lights.

## 7 | Rendering

### > IBL node attributes

The first *Samples* parameter specifies the number of important lights that must be sampled. The second parameter quasi-randomly selects a certain number of secondary (fill) lights.

#### Low samples

Low Samples specifies the number of light samples taken from IBL during final gathering. It defaults to 1/8th of the regular samples (that is, 5/2).

#### Vary Focus

Each “directional light” in the control texture sphere determines its direction. Turning on Vary Focus slightly offsets that direction (randomly) and thus improves quality.

#### Disable Backlighting

If lights on the backside of surfaces do not contribute to the surfaces' illumination (i.e., there is no translucency in the scene), you should turn this on. It optimizes sampling significantly.

#### Emit Diffuse, Emit Specular, Use Ray Trace Shadows, Shadow Color, Ray Depth Limit

These parameters are identical to attributes on Maya's standard lights.

#### Photon Emission

Photons can be emitted from the IBL environment sphere. This requires *Global Illumination* and/or *Caustic* photons to be turned on in the Render Global Settings window. The emission direction is chosen randomly for individual photons. Similar to light emission, a photon picks up the color based on its emission direction from the IBL texture (file or procedural), possibly adjusted by color gain and offset. The results of this maps to a mental ray photon emission shader.

### Emit Photons

Turn on, if you want to emit photons from the infinitely distant IBL environment.

### Globillumination

Determines how many global illumination photons are emitted.

### Caustic Photons

Determines how many caustic photons are emitted.

### Exponent

Determines the exponent used for photon emission.

### Standard emission

If off, photons will be stored on first hit. This is useful if IBL is to be achieved using global illumination photons alone. In terms of a real-world environment you can think of this switch as photons from the Sun being scattered in the atmosphere before reaching any surface.

Turn this option on, if you are emitting caustic photons, or if you are emitting light in combination with photons.

## 7 | Rendering

> Photon and Final Gather visualization maps

### Photon and Final Gather visualization maps

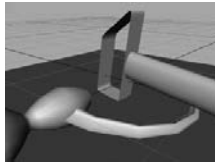

Shaded view of a scene

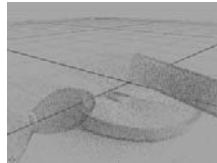

Photon map visualization

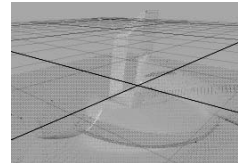

Final Gather visualization

You can generate a 3-dimensional visualization of a photon map or final gather map.

Generate a map visualization to see the distribution of photons (and their energies) and final gather points (with stored irradiance) in the scene. This feedback can help you diagnose possibly unexpected global illumination effects or tune your scene more efficiently to get the desired look.

Generated photon or final gather visualization maps appear in shaded and wireframe Scene views. Normals and directions are only visible in wireframe view. In shaded view, photons and final gather points are displayed as colored points, the color representing the irradiance estimate.

**Note** Photon or final gather visualization maps are not visible in final rendering.

#### To generate a photon or final gather visualization map

- 1 Select Window > Rendering Editors > mental ray > Map Visualizer.

If a mapVizShape node does not already exist in the scene (that is, if a visualization has not already been generated for the scene), a *mapVizShape* node is created and the mental ray Map Visualizer window appears.

- 2** Adjust the display attributes of the visualization map.  
See "mapVizShape node" on page 287 for details.
- 3** Do any of the following:
  - Click Refresh to reload the map after you make changes.
  - Click Close to close the window but retain the visualization map (and thus the mapVizShape node).

## mapVizShape node

When you generate a photon or final gather visualization map, the *mapVizShape* shape node is added to the scene. Adjust the attributes of this node to change the visualization map.

### Map File Name

Name of the photon or final gather map file to be created and saved.

### Photon Visibility

If the map is a photon map, turning any of these options off hides the corresponding photon type.

### Options

#### Point Size

This is the size of light rays on the surface to be drawn in screen space.

#### Normal Scale

Each photon and final gather point has an associated normal that tells which side of a surface it is on. Raise *Normal Scale* above zero to display normals.

## 7 | Rendering

### > Render shader glow

#### Direction Scale

Raise *Direction Scale* to display the direction from which photons arrived on the surface.

#### Search Radius Scale

Irradiance is estimated from a photon map by looking up photons within a certain radius. *MapViz* automatically determines a good search radius for visualization. That radius can be scaled by *Search Radius Scale*.

## Render shader glow

Support for shader glow has been added.

## Render particle motion blur

Motion-blurred particles are now supported with mental ray for Maya.

## Improved Lightmap/CPV generation time

Lightmap and CPV generation time has been significantly improved.

## Light linking

### Light-linking for mental ray shaders

mental ray for Maya now provides automatic light linking at render time, if the light array parameters are not connected. In other words, when rendering and exporting the scene, mental ray for Maya looks up the Maya light linking information between lights and the object, and connects light nodes to the light array parameters of the shader.



Automatic light linking happens only if the light array parameter is not connected to any light (shared materials are not supported); if the shader is assigned to two different objects, and those two objects have different light linking, one light linking relationship will be applied to both objects. Previous files may not render exactly as they had before, and you may have to make some minor adjustments.

The default light is not considered in the automatic light linking.

## Light-linking on particle instances

Light-linking on particle instances is fully supported.

## Support for diagnostics

Support for mental ray for Maya diagnostics has been added.

## Better support for mental ray texture formats

Support for the following mental images texture formats has been added to Maya's File Texture and Image Plane nodes:

- `.ct`  
RGB/RGBA data types at 8bpp,16bpp, or floating-point 32bpp
- `.st`  
S data type at 8bpp, 16bpp, or floating-point 32bpp
- `.map`  
S, RGB, RGBA data types at 8bpp, 16bpp, or floating-point 32bpp. Tiled and pyramidal variants are supported.

## 7 | Rendering

### > New support for triangle export of polygon meshes

You can now see these formats in Maya's rendering UI (HyperShade swatches, Attribute Editor preview swatches, etc.) and use them with the Maya Software renderer (though they get truncated to 8 bit). (These formats have always been supported for rendering with the mental ray renderer.)

## New support for triangle export of polygon meshes

Two dynamic attributes (`exportTriangles` and `miTriangles`) use the triangulation of Maya and exploit a far more memory effective translation to mental ray for Maya.

If the Maya source geometry is actually a triangular mesh there is no difference in mental ray for Maya, but much less memory is used.

Enable this mode globally for all meshes in the scene via a dynamic attribute on render globals node '`exportTriangles`' (bool), or on a per-shape basis via a dynamic attribute '`miTriangles`' (bool).

# 8

# Painting

## Paint Effects

The following is new for Paint Effects in Maya 6.

### Paint Effects on Polygons

As of Maya 6 Paint Effects can be used on polygons. Previously Paint Effects could be used only on NURBS. Before painting on polygons, select the geometry and then select Paint Effects > Make Paintable.

### UV linking for Paint Effect on polygons

You can choose which UV set to use for Paint Effects on polygons by selecting Window > Relationship Editors > UV Linking > Paint Effects/UV.

### Isolating Paint Effects strokes for rendering

You can now isolate particular strokes when test rendering. Select Render Active from the Renderable Objects drop-down list in the Common tab of the Render Global Settings window.

### Progress indicator for rendering Paint Effects

When you render a Paint Effects pass you can determine the percentage of rendering that has been completed by viewing the progress indicator in the lower-left corner (Help Line) of the Maya window.

## Artisan

The following is new for Artisan tools in Maya 6.

### Artisan Tools ported to the new architecture

As of Maya 6 the last of the Artisan tools were ported to the new, and now standard, Artisan architecture:

- Sculpt Surfaces Tool (NURBS)
- Sculpt Polygons Tool
- Paint Set Membership Tool
- Paint Blind Data Tool
- Paint Fur Attributes Tool
- Paint Cloth Properties Tool
- New Paint Cloth Collision Properties Tool 
- New Paint Hair Tool 

There are no more Artisan tools in the former Artisan architecture.

For more information, see *Artisan Brush Tool Settings* in the online help.

### New Paint Hair Tool

We've added a new Paint Hair Tool to paint attributes of a dynamic hair system. Hair is a new feature for Maya Unlimited. For more information, see *Introducing Hair* in the online Hair and Dynamic Curves guide. See also Hair > Paint Hair Tool in the online Hair and Dynamic Curves guide.

## New Paint Cloth Collision Properties Tool

We've added a new Paint Collision Properties Tool you can use to paint collision properties of cloth objects. For more information, see "Painting collision object properties" on page 327.

## Sculpt Surfaces Tool improvements

Sculpt Surfaces now respects Global Stitch. The internal Artisan stitching has been removed.

The revised workflow is to select the surfaces to be sculpted and apply a Global Stitch before using the Sculpt Surfaces Tool.

## Paint Scripts Tool improvements

We added new flags to give access to the direction and brush center information from the Paint Scripts Tool (formerly known as the Script Paint Tool). You can obtain the direction of paint stroke or stamp position in the SetValueCommand and use them. These flags have to be set in InitializeCommand of the script. See "Paint Scripts Tool improvements" on page 360.

## 3D Paint Tool

The following is new for the 3D Paint Tool in Maya 6.

### Paint Sculpt Map

Paint Sculpt Map is a button in the Sculpt History section of the sculpt node. It invokes the 3D Paint Tool so you can paint deformation strengths over the surface of the deformer. If a non-file texture is connected to the deformer, it will be disconnected before painting begins.

## **8 | Painting**

### **> Paint Sculpt Map**

This makes it easy to use the Sculpt Deformer to create realistic muscle shapes. For more information, see “Sculpt deform with texture map” on page 205.

# 9

# Fluid Effects

**Note** Fluid Effects is available only in Maya Unlimited.

## Fluids cache performance enhancements

### Control the creation of temporary fluids cache files

Fluid caches are disk files with the extension `.mcfp` that are stored in your project's *data* directory. By default, when you open a scene file, Maya creates copies of a scene's fluids cache files and places them in your system's temporary file directory.

**Note** You can use the `diskCache -tmp` MEL command to determine the location of your temporary disk cache files.

These temporary files are used to store any changes to your fluids cache that occur between file saves (File > Save Scene) and are required for you to be able to edit your fluids cache.

**Warning** When the Copy Cache File Locally attribute is off, you cannot append or truncate your fluids cache.

In Maya 6, you can use the new *Copy Cache File Locally* attribute to turn off the creation of these local copies for any fluids playback cache file. This is useful if you are low on disk space or are using a

## 9 | Fluid Effects

> Save one fluids cache file per frame

network for distributed rendering. The Copy Cache File Locally attribute is located in the *Caching Node* section of the Fluid's Cache in the attribute editor.

### To turn off the creation of local temporary fluids cache files

- 1 Save your scene.  
This copies over your temporary cache file to your project data directory.
- 2 Select the cached fluid in your scene and open the Attribute Editor.
- 3 In the Cache *\_fluidShapen* tab, expand the Caching Node section.
- 4 Turn off Copy Cache File Locally.
- 5 Save your scene once again.

Now when you open your scene, Maya does not copy your fluids cache to the temporary directory, and when you save your scene, Maya does not copy your fluids cache from the temporary directory to the permanent location.

## Save one fluids cache file per frame

By default, Maya creates one cache file per fluid. However, some systems impose a limit on the maximum size a file can have. The size of a fluids cache file depends on the resolution of the fluid being cached and the properties (density, velocity, and so on) stored in the cache. Large fluid caches can sometimes exceed a system's file size limit.

In Maya 6, you can save fluid caches in the *One File per Frame* (OFpF) format, which creates one cache file for each frame specified in Cache Time Range. The One File per Frame option is located in the Create Cache Options window.



Single fluids cache files are first stored in the disk cache temp directory and are only copied over to your project's disk cache data directory on file save. Since OFpF fluids cache files are created and stored *directly* on your project's disk cache data directory, you need to consider the following limitations:

- Your scene must first have a name before you can create an OFpF fluids cache. You can name your scene by selecting File > Save As or by using the `file -rename` MEL command.
- Since OFpF caches are written directly into the project data directory, Maya cannot always determine when it's safe (for example, whether or not a disk cache file in the project data directory may be referenced by an unopened scene) to delete the cache file from the disk. Therefore, it is up to you to remove any unneeded cache files from the data directory.
- Since OFpF caches always copy the cache file for the current frame to the temporary directory (MEL: `diskCache -tmp`) control over the creation of the temporary file copies is disabled for OFpF caches.

---

**Tip** If a cache node is named `cache_fluidShape1`, the name of this intermediate file is available via the MEL command:

```
getAttr cache_fluidShape1.hiddenCacheName.
```

The location of this file is the `diskCache -tmp` directory.

---

## 9 | Fluid Effects

> How do I create an One Frame per File fluids cache?

- Note
- You cannot change the Cache File Format once a cache has been created. You must first delete the existing cache and re-create it using the desired format.
  - Over and Under sampling are only available for caches created in the Single File format.

### Example

For a fluids cache for frames 1 to 5, *One File per Frame* creates 5 different fluids cache files. Each file is named according to the following naming scheme:

```
segmentPrefix%N_fluidShapeName_%F.mcfp
```

Where %N is the uniqueness identifier for segmentPrefix chosen by the system to guarantee unique file names among all diskCache nodes in the file scene and %F is the start frame for data in the cache file.

If the 5 frame cache in this example has been created for scene file *joe.mb*, the OFpF fluids cache files might be named:

```
joe.mb1_fluidShape12_1.mcfp    (frames 1)  
joe.mb1_fluidShape12_2.mcfp    (frames 2)  
joe.mb1_fluidShape12_3.mcfp    (frames 3)  
joe.mb1_fluidShape12_4.mcfp    (frames 4)  
joe.mb1_fluidShape12_5.mcfp    (frames 5)
```

## How do I create an One Frame per File fluids cache?

### To create an OFpF fluids cache

- 1 Save your scene.

- 2** Select the fluid for which you want to create a segmented cache.
- 3** If your fluid already has a cache, delete its current cache by selecting Fluid Effects > Delete Cache.
- 4** Select Fluid Effects > Create Cache > .  
The Create Cache Options window appears.
- 5** In the Cache File Format section, turn on One File per Frame.
- 6** Click Create or Apply to create a cache for each frame of your fluid. If you click Create, the Create Cache Options window closes. If you click Apply, the Create Cache Options window remains open.

**Warning** Be aware that caching a fluid effect—especially a large fluid—may tie-up your system for an extended period of time and this operation *cannot* be interrupted.

Maya creates one cache file for each frame of your fluid.

- 7** Save your Maya scene.

## Advanced Fluids Caching in MEL

With the new `doFluidsDiskCache` MEL command, you can segment fluid caches. A segmented cache is a fluids cache that is broken-up into multiple segments or chunks, where each segment contains a specified number of frames. Segmented caches can be used to split a large cache into smaller, more manageable files.

Since One File per Frame (OFpF) caches are a special type of a segmented cache (with a segment size of one), any limitations listed in the OFpF section also apply to segmented caches. See “Save one fluids cache file per frame” on page 296.

## 9 | Fluid Effects

### > Advanced Fluids Caching in MEL

When you create any segmented cache for a fluid, the dynamic attribute *Segment Start Frame* is added to the `diskCache` node. This attribute connects to an expression node called `%N_currentSegment` (where %N is the segment naming prefix) which uses an animation curve to determine the appropriate `segmentStartFrame` value for the disk cache at the current time. *Segment Start Frame* cannot be modified directly in the Attribute Editor.

Maya uses the `segmentStartFrame` value to generate the name of the segment file containing the cache data for the fluid at the current time. This cache file is then copied from the project's data directory to the `mcfp diskCache -tmp` directory as needed.

The MEL procedure `doFluidsDiskCache` takes two arguments: `doFluidsDiskCache (int $version, string $args[])` where `$version` is 2 for Maya 6, and `$args` is a string array whose values are mapped as follows:

```
string    $cacheType           =    $args[0];
int       $rangeMode           =    $args[1];
int       $$sampling            =    $args[2];
float     $diskCacheStartTime   =    $args[3];
float     $diskCacheEndTime     =    $args[4];
int       $$samplingRate        =    $args[5];
int       $cacheDensity         =    $args[6];
int       $cacheVelocity        =    $args[7];
int       $cacheTemperature     =    $args[8];
int       $cacheFuel            =    $args[9];
int       $cacheColor           =    $args[10];
int       $cacheDensity         =    $args[11];
int       $doSegment            =    $args[12];
string    $namingPrefix         =    $args[13];
int       $segmentSize          =    $args[14];
```

The last three elements of the `$args` array relate to segmented cache files:

- `$doSegment` must be 1 to create segmented of OFpF caches
- `$namingPrefix` is a user-specified string to identify the cache files and expression nodes created in this operation
- `$segmentSize` is used to specify how many frames are stored in each cache file segment.

## Example

The following command creates a segmented fluid cache from frame 1 to frame 100, with a segment size of 30:

```
doFluidsDiskCache 2 { "mcfp", 3, 1, 1, 100, 1,  
1, 1, 1, 1, 1, 1, 1, "joe.mb", 30 };
```

Since segmented fluids cache names depend on the name of the fluidShape being cached, the files created in your disk cache data directory might be named as follows:

```
joe.mb1_fluidShape12_1.mcfp  
joe.mb1_fluidShape12_31.mcfp  
joe.mb1_fluidShape12_61.mcfp  
joe.mb1_fluidShape12_91.mcfp
```

At frame 10, the `segmentStartFrame` attribute of the `diskCache` node has a value of 1 because the first cache segment contains the cache information for frame 10, and `segmentStartFrame` has a value of 61 at frame 75 because the third cache segment contains cache information for frames 61 to 90. Note that the last file created only contains cache information for frames 91 to 100.

## Troubleshooting the Fluids cache

### Maya cannot read the fluids cache

The following sections apply to both playback and initial state fluid caches.

## 9 | Fluid Effects

- > There is not enough space in your temp directory

### There is not enough space in your temp directory

Maya cannot read the cache for the current fluid because your default temp directory does not have enough space. You can either make space on the drive where your temp directory is located, or you can change the path of your temp directory by editing your TEMP environment variable definition.

The default temp directories are:

(Windows)	<code>username\Local Settings\Temp</code>
(Mac OS X)	<code>/Users/username/Documents/temp</code>
(IRIX and Linux)	<code>/usr/tmp</code>

**Note** If your temp directory is set to something other than the default, you can still locate your temporary disk cache files using the `diskCache -tmp` MEL command.

#### To make space in your temp directory

- 1 Browse to your temp directory.
- 2 Delete any nonessential files to free up space on the disk where the directory is located.
- 3 Check that there is now enough space in your temp directory for your fluids cache.

#### To change the temp directory folder

- 1 Do one of the following:

> The fluids cache is on a remote network drive that you are unable to access

- (Windows) Open the Control Panel and select System > Advanced > Environment Variables. Select TEMP from the list of *user* (not *system*) variables and click Edit. Enter a new system path for the TEMP environment variable and click OK.
- (Mac OS X) In the Maya.env file, type TEMP = *path* to define a new path for your temp directory. Save and close the Maya.env file.
- (IRIX and Linux) In a UNIX shell type: setenv TMPDIR *path* and press Enter. *path* is the new path for the temp folder.

**2** If Maya is running, restart Maya.

### **To turn off the creation of temporary cache files**

See "To turn off the creation of local temporary fluids cache files" on page 296.

### **The fluids cache is on a remote network drive that you are unable to access**

Maya cannot read the current fluid's cache because the cache is located on a remote network drive that does not have shared permissions. If this occurs, you need to make the file available again.

### **Maya cannot find the current fluids cache**

When a Maya file and a fluids cache are copied to a new location, the path from the Maya file to its fluids cache may break. If this occurs, you need to re-establish the connection between the fluid and its cache.

## 9 | Fluid Effects

> Maya is unable to create a playback cache for the current fluid

### To re-establish the link between a fluid and its cache data

- 1 Open your Maya file, select the fluid whose cache cannot be found, and then open the Attribute Editor.
- 2 In the Attribute Editor, select the cache or initial state node.
- 3 Click the folder button next to the Cache File Name field to browse (locally or over the network) for the current fluid's cache.
- 4 Select the cache and click Assign to re-establish the connection between the current fluid and its cache.

### To re-establish the link between a fluid and its segmented cache data

Make sure that your segmented cache files are located in the folder specified in the *Disk Cache* field of your current project's settings. To view or change the contents of your current project's Disk Cache field, go to File > Project > Edit Current.

**Warning** The Disk Cache field specifies the destination for all your current project's cache files. For example, fluids caches, jiggle caches, hair caches and so on.

## Maya is unable to create a playback cache for the current fluid

### There is not enough space on the specified disk

The temp folder that you have designated as the destination for your fluids playback cache is on a disk that does not have enough space for the cache data.



> When saving fluids caches on Windows or Linux systems, the resulting files are incomplete or contain blank frames

### **To make more space on the disk**

- Delete any unnecessary or non-essential files from the temp folder's disk to free up space for the fluids playback cache.
- Change the destination of the fluids playback cache data. For example, you can specify a new temp folder on a different disk as the destination for the fluids playback cache.

### **To turn off the creation of local temp fluids cache files**

See "Control the creation of temporary fluids cache files" on page 295.

## **When saving fluids caches on Windows or Linux systems, the resulting files are incomplete or contain blank frames**

The size of the cache file cannot exceed 2 gigabytes (GB). Cache files larger than 2GB will fail to write out completely. When saving a fluids cache file, Maya writes out up to the 2GB limit and then ignores the rest of the cache. You can work around this limitation by creating your fluids cache as segments (for example, 500MB mini caches). Each cache segment can then be rendered separately. To segment your fluids cache, see "Save one fluids cache file per frame" on page 296.

## **General Fluids improvements**

### **Fluids render in mental ray for Maya**

You can now render Maya fluids as volumes or surfaces with mental ray for Maya, and you can attach them as 2d or 3d textures. Fluids are exported to .mi format.

## 9 | Fluid Effects

### > Replace Cache Frame

## Replace Cache Frame

In Maya 6, you can use the new *Replace Cache Frame* menu item to replace cached data for a selected fluid with the contents of the fluid at the current time. Replace Cache Frame is located under the Fluid Effects menu in the Maya main menu bar. Replace Cache Frame is only available for fluid caches created with the *One Frame per File* cache format.

### To replace the fluids cache at the current frame

- 1 Make sure that your fluid has an OFpF cache.  
See "To create an OFpF fluids cache" on page 298.
- 2 Drag the current time indicator in the Time Slider to the frame you'd like to replace in the cache.
- 3 Modify the contents of the fluid. For example, you can use the Paint Fluids Tool or the `setFluidAttr` MEL command.
- 4 Select Fluid Effects > Replace Cache Frame.  
The current contents of the fluid is saved into your fluids cache at the current time and replaces the previous cache contents.

## Easily view fluids cache contents

You can now easily view fluids cache files that do not have a container. In previous versions of Maya, there was no way of knowing the contents of a fluids cache without creating a fluid container to view the cache's contents.

In Maya 6, you can view the contents of a fluids cache file by selecting the `.mcfi` or `.mcfp` fluids cache file on your disk and then dragging it into Maya's scene view. When you drag a fluids cache file into Maya, Maya automatically creates the appropriate type of container for the fluids cache. The *resolution* of the fluid

## 9 | Fluid Effects

> Easily view fluids cache contents

that is created is determined by the cache data, and the *size* of the fluid is determined by the current settings in the Create 2D Container or Create 3D Container option windows.

## **9 | Fluid Effects**

- > Easily view fluids cache contents

# 10

# Fur

Note Fur is available only in Maya Unlimited.

The following are improvements to Fur for Maya 6.

- “Rendering Fur in mental ray”
- “New Render Stats in Fur Feedback Shape node”
- “New mental ray Fur rendering options”
- “Fur Equalizer Maps improvements”
- “Fur on Subdivision Surfaces”
- “Paint Fur Attributes Tool improvements”
- “Update maps for referenced scenes or externally painted fur attributes”
- “Fur Feedback improvements”
- “Effect of lighting intensity on Fur”
- “Reverting to former Maya Fur behavior”

## Rendering Fur in mental ray

You can now render Fur in mental ray. Fur in mental ray is rendered within the main render pass, rather than as a post process, which allows for Fur to show up in reflections and refractions, and through transparent objects.

When rendering Fur in mental ray, keep in mind the following:

- Along with regular texture baking workflow, Fur in mental ray can now follow the complex shading connections, for example, 3D textures, for color attributes.

## 10 | Fur

### > Rendering Fur in mental ray

- Calculate Area Values has no effect when rendering Fur with mental ray. In order to evenly distribute fur over a number of differently-sized NURBS patches, you need to adjust the baldness maps to compensate. Another alternative is to convert to a single polygon mesh.
- Rendering Fur in mental ray for Maya can be significantly slower than in the Maya Software renderer.
- To improve the quality of Fur rendered with mental ray, set low Contrast RGB values and high Fur Sampling rates. The Preview Fur setting in Render Globals gives a good starting point.

For more information, see *mental ray for Maya renderer* in the online Rendering guide and also *Rendering scenes with fur* in the online Fur guide.

#### Related topics

- ❖ “New Render Stats in Fur Feedback Shape node” on page 314
- ❖ “New mental ray Fur rendering options” on page 315

> Rendering in the Maya software renderer vs. mental ray for Maya

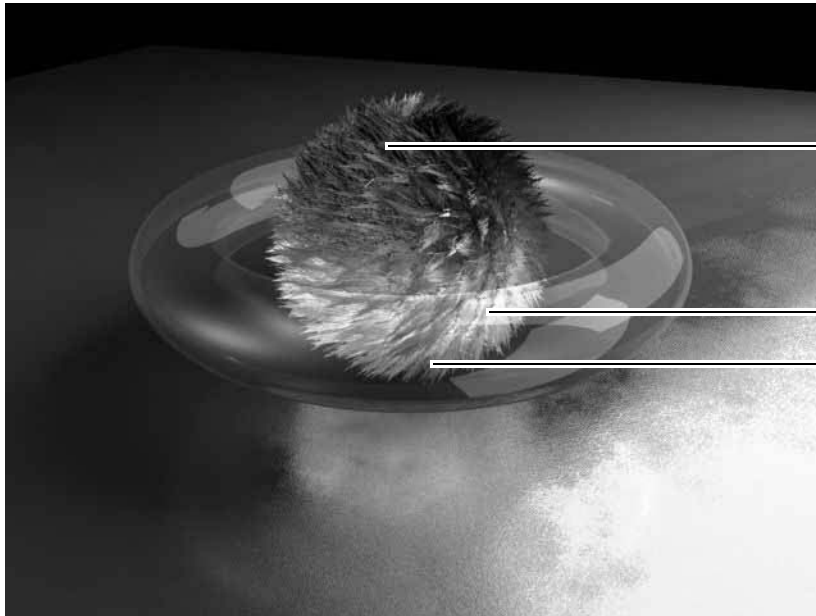

Fur with Final Gather and raytraced color shadows

Caustics and Global Illumination received by Fur

Fur visible through transparent objects

## Rendering in the Maya software renderer vs. mental ray for Maya

Refer to the following table for the differences between rendering Fur in the Maya software renderer and mental ray for Maya.

<b>Fur item</b>	<b>Maya software renderer</b>	<b>mental ray for Maya</b>
Support for reflections	None	Fur shows up in reflective material, but is not reflective itself

## 10 | Fur

> Rendering in the Maya software renderer vs. mental ray for Maya

<b>Fur item</b>	<b>Maya software renderer</b>	<b>mental ray for Maya</b>
Support for refractions	None	Fur is refracted through refractive material, but is not refractive itself
Support for colored shadows	Supports only black shadows	Yes
Support for correct penumbra and drop off	Not accurate	Yes
Support for correct DOF composition	Not accurate	Yes
Support for transparency	Fur can be transparent, but is not visible through transparent material (can render in layers and composite)	Fur is able to be transparent and to show up through transparent material
Use of .sbs files	Geometry information is written to a .sbs file that is then used by the Fur renderer	.sbs file is used for equalizer map generation only
Advanced Fur Render	Can be used to generate fur files, equalizer maps, shadows and images	Can be used to generate equalizer maps only



> Rendering in the Maya software renderer vs. mental ray for Maya

<b>Fur item</b>	<b>Maya software renderer</b>	<b>mental ray for Maya</b>
Support for motion blur	3D only	Yes. For moving objects with fur or moving fur (attractors), set Motion Blur to “Exact” in the mental ray tab of the Render Global Settings window. If the camera is moving, set Motion Blur to either “Linear” or “Exact” in the mental ray tab of the Render Global Settings window.
Need to add Fur Shadowing Attributes to lights to shadow Fur	Yes	No
Support for fast fake Back and Root Shading (AutoShade)	Yes	No
Support for ray-traced shadows	No	Yes
Support for depth-map shadows	Yes	Yes
Fur integrated into scene	As a post process via z-depth composite	Fully integrated

## 10 | Fur

> New Render Stats in Fur Feedback Shape node

<b>Fur item</b>	<b>Maya software renderer</b>	<b>mental ray for Maya</b>
Support for area value calculations (Fur Globals > Calc. Area Values)	Yes	Currently not possible
Support for 16 bit rendering	No	Yes

### New Render Stats in Fur Feedback Shape node

A new Render Stats section has been added to the FurFeedbackShape node. The Render Stats include some settings unique to using the mental ray for Maya renderer.

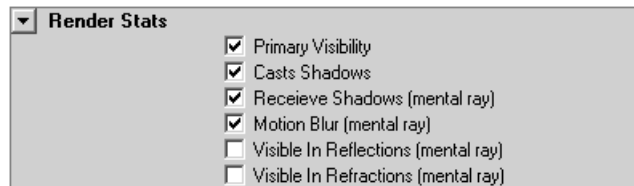

The Maya Fur renderer uses the Casts Shadows and Primary Visibility settings. With these settings users have control over shadow casting and primary visibility on a per FurFeedback node basis. Users can now assign geometry and fur (FurFeedback) separately on different render layers. The Maya Fur renderer now respects render layers so users now have the ability to render only fur and not underlying geometry.

#### Primary Visibility

When on, the fur is visible in the view and renders.

### **Casts Shadows**

Turns on the shadow casting ability of the fur. To make shadows render faster, for fur that does not need to cast shadows, turn off Casts Shadows.

### **Receive Shadows (mental ray)**

Turns on the shadow-catching ability of the fur. Works only when using the mental ray for Maya renderer.

### **Motion Blur (mental ray)**

Turns on motion blur for the fur. You must also turn on Motion Blur in the Render Global Settings window. Only affects the mental ray for Maya renderer.

### **Visible in Reflections (mental ray)**

When on, the fur reflects in reflective surfaces. Works only when using the mental ray for Maya renderer.

### **Visible in Refractions (mental ray)**

When on, the fur refracts through transparent surfaces. Works only when using the mental ray for Maya renderer.

## **New mental ray Fur rendering options**

A new mental ray section has been added to the FurFeedbackShape node. The mental ray settings are used when Fur is rendered in mental ray. These are descriptions of the options.

### **Override Caustics Settings**

Turn this on to override the Caustics settings for Fur only. Then set the values for Caustic Accuracy and Caustic Radius. For descriptions of these attributes and for more information

## 10 | Fur

### > New mental ray Fur rendering options

about Caustics, see *Caustics and Global Illumination* in the online Lighting guide. See also *Global illumination and caustics workflow* in the online Lighting guide.

#### Override Global Illumination Settings

Turn this on to override the Global Illumination settings for Fur only. Then set the values for Global Illum Accuracy and Global Illum Radius. For descriptions of these attributes and for more information about Global Illumination, see *Caustics and Global Illumination* in the online Lighting guide. See also *Global illumination and caustics workflow* in the online Lighting guide.

#### Override Final Gather Settings

Turn this on to override the Final Gather settings for Fur only. Then set the following options: Final Gather Rays, Final Gather Min Radius, Max Radius, Final Gather View, and Final Gather Filter. For descriptions of these attributes and for more information about Final Gather, see *Final Gather* in the online Lighting guide. See also *Render with final gather* in the online Lighting guide.

#### Number of Samples

These settings relate to anti-aliasing when rendering with mental ray. For more information, see *Anti-aliasing and flicker* in the Rendering guide.

---

**Note** These per object sampling settings must lie within the range of the mental ray global sampling settings, otherwise they will be clipped.

---

**Min Sample  
Level**

This is the guaranteed minimum number of samples per pixel used when processing an image. Based on Contrast Threshold (adaptive) settings, mental ray for Maya will increase these samples as needed.

**Max Sample  
Level**

This is the absolute maximum number of samples per pixel used when processing an image.

## Fur Equalizer Maps improvements

In the Fur Globals window there are now four options for equalizer maps:

- No Equalizer Maps
- Default Equalizer Maps
- Read Equalizer Maps (Per Surface)
- Custom Equalizer Maps (Per Fur Description, Per Surface)

## New Custom Equalizer Maps option

We've added a Custom Equalizer Maps option so you can:

- paint your own equalizer maps and read them through the animation
- use any file as an equalizer map and read it through the animation

**Note** Use Custom Equalizer if you want to read equalizers in a scene referenced to a different project. This is because custom equalizers support absolute paths.

## 10 | Fur

### > Changes to Read Equalizer Maps option

If you select Custom Equalizer Maps, you can see the new Custom Equalizer attribute that appears in each fur description at the bottom of the list of attributes in the Attribute Editor. This attribute is grayed out when the Custom Equalizer Maps option is not selected.

The Custom Equalizer attribute can be mapped or painted like any other fur description attribute. If you don't make any changes to a particular fur description, the default equalizer map is generated and used. When you paint the attribute for the first time, the map is initially set to the default equalization. That's because when you select Custom Equalizer Maps, default equalizers are automatically generated and a copy is saved for each fur description. The path of the Custom Equalizer Map files is displayed in the Fur Description in Details > Maps. The path should be able to be relative if the map resides in the standard project directory or absolute if the map resides elsewhere.

### Changes to Read Equalizer Maps option

If you select Read Equalizer Maps, and a map has not already been generated through Advanced Fur Rendering, you are prompted with the following dialog box if you want to generate a default map. Otherwise you would choose your own map.

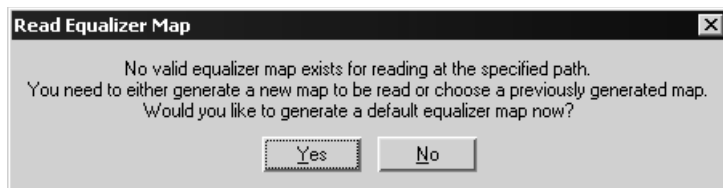

In either case, the path is filled in and can be seen and edited in the Reference Paths section of the Fur Globals window. This path is grayed out if any of the other three options are selected (No, Default, Custom).

## Fur on Subdivision Surfaces

You can now create and work with Fur on subdivision surfaces with the following limitations:

- Direction painting does not work. Paint the Polar attribute instead.
- There is no color feedback for subdivision surfaces in the Paint Fur Attributes Tool.
- You cannot attach a grid of attractors to a subdivision surface. You can, however, attach attractors to selected subdivision surface faces.

Due to these limitations, for major character work involving Fur, you may still wish to convert your subdivision surfaces to polygons.

## Paint Fur Attributes Tool improvements

The Paint Fur Attributes Tool has been ported to the new standard Artisan architecture resulting in the following benefits:

- you can use it on NURBS, polygons, and subdivision surfaces
- UVs no longer have to be contiguous, therefore you can use Automatic Mapping to create them
- World space reflection
- Color feedback on polygons

For more information, see *Artisan Brush Tool Settings* in the online Paint Effects, Artisan, and 3D Paint guide.

## 10 | Fur

> Update maps for referenced scenes or externally painted fur attributes

### Update maps for referenced scenes or externally painted fur attributes

We've added Update Maps to the Fur menu. Use this to update attribute maps when you:

- map or paint fur attributes in scenes that are referenced
- paint fur attributes outside of the Paint Fur Attributes Tool, such as in the Paint Effects canvas, or in an external application, such as Photoshop

### Fur Feedback improvements

We've made several improvements to Fur Feedback.

- You can now display Fur Feedback for more than one fur description at the same time. See "Switching between Fur Feedback" below. (Each Fur description has its own Fur Feedback.)
- To see just one Fur Feedback for only one fur description (for speed or clarity), you can select and hide the others. See "Hiding and showing Fur Feedback" below.
- Hidden fur will no longer render, which means, in this respect, Fur behaves the same as other objects in Maya.
- You can select all fur in a scene quickly by selecting Edit > Select All by Type > Fur.
- In a scene in which the transform node of FurFeedback has transformations applied, interactive and rendered fur now respects these transformations.

### Hiding and showing Fur Feedback

In previous versions of Maya you used the Show Feedback menu item to show fur. Now you can hide and show fur using the Display menu.



**To hide all fur**

Select Display > Hide > Fur.

**To show all fur**

Select Display > Show > Fur.

**To hide fur for one fur description**

- 1** Select the FurFeedback.
- 2** Do one of the following:
  - Select Display > Hide > Hide Selection.
  - Press Ctrl + h.

**To show the last hidden fur description**

Do one of the following:

- Select Display > Show > Show Last Hidden.
- Press Ctrl + Shift + h.

## Switching between Fur Feedback

In previous versions of Maya you used the Show Feedback menu item to switch between fur descriptions and you could only see one of them at a time. Now that you can display Fur Feedback for multiple fur descriptions at the same time, you don't need to switch between Fur Feedback.

To help you see what fur is displayed, Color Feedback Enabled is on by default (located in the FurFeedback node). Also, the default value for Fur Accuracy is now 1.

## Transforming Fur

In a scene in which the transform node of FurFeedback has transformations applied, interactive or rendered fur now respects these transformations. This is not only logical, but also consistent with how other transform nodes behave in Maya. In order to make this fix, a change was made in the transformation calculations for displaying or rendering fur. The effect is that fur displayed or rendered with the new version of Maya may look different compared with previous versions if there are transformations on the FurFeedback node. If you want to maintain compatibility in Maya Fur display or render, define the environment variable `MAYA_FUR_OLD_BEHAVIOR`. For more information about this variable, see "Reverting to former Maya Fur behavior" on page 322.

## Effect of lighting intensity on Fur

In a scene in which the intensity of the lights exceeded 1.0, rendered fur would never be brighter than the diffuse and specular color values defined for the fur. You would expect the rendered fur to become increasingly brighter as the lighting increased. This is not only logical, but also consistent with how other renderers, including the Maya Renderer, behave with identical lighting and material assignments. In order to make this fix, a change in the shading calculations for rendering fur was implemented. The effect is that fur rendered with Maya 6 may look different compared with previous versions. If you want to maintain compatibility, define the environment variable `MAYA_FUR_LIGHT_CLAMPING`.

## Reverting to former Maya Fur behavior

With the changes to Maya Fur, if you wish to revert to the former Maya Fur behavior, you can set the environment variable `MAYA_FUR_OLD_BEHAVIOR`.

If this variable is set it does the following:

- In a scene in which the transform node of FurFeedback has transformations applied, interactive and rendered fur ignores these transformations. (These transformations are respected in the new version of Maya.)
- It ignores the Casts Shadows and Primary Visibility attributes in the Render Stats section of the FurFeedbackShape node.
- You can assign geometry and fur (FurFeedback) separately on different render layers and the Maya Fur renderer ignores the render layer of fur (as it did formerly).

Essentially there will be behavioral differences between mental ray Fur and Maya Fur if this environment variable is set.

## **10 | Fur**

- > Reverting to former Maya Fur behavior

Note Cloth is available only in Maya Unlimited.

The following are improvements and enhancements to Cloth for Maya 6.

- "Improved support for Cloth objects" on page 325
- "Painting tessellation on garments and panels" on page 332
- "Visualizing Cloth stress" on page 333
- "Per-face collision depth" on page 336
- "Stitch attribute for Cloth constraint" on page 337
- "Mesh constraint improvements" on page 338
- "Solver performance improvements" on page 338
- "Advanced Cloth cache editing" on page 343

## Improved support for Cloth objects

### Improvements for Cloth objects

We've made various improvements for working with cloth objects. A *cloth object* is a piece of geometry simulated as cloth. You create cloth objects from polygonal shapes or NURBS shapes. The original shape is hidden and the tessellated cloth shape is displayed. The original shape and the cloth shape are grouped under the object's transform. For more information, see *Create a cloth object* in the online Cloth guide.

Some features have been made available for cloth objects that were previously available only on garments created from panels. Other new features have been added specifically for cloth objects.

## 11 | Cloth

### > Constraints on Cloth objects

## Constraints on Cloth objects

All cloth constraints now work on cloth objects. For information about constraints, see *Use constraints* in the online Cloth guide.

## Cloth object resolution

Cloth object constraints support resolution independence. If you change the resolution of a cloth object, for example, change the number of subdivisions, the constraint locations update accordingly. See the following illustration.

See the selected vertices at the bottom center of the the Cloth Object plane

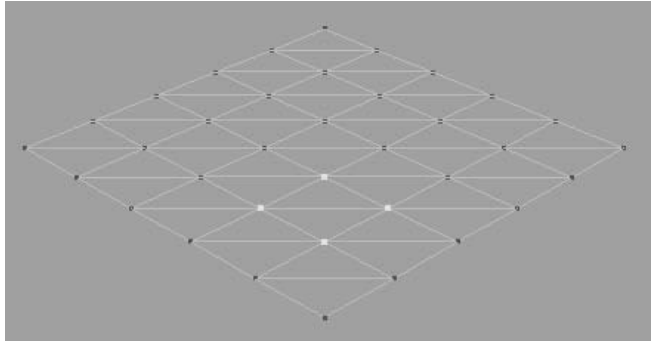

See the same selected vertices now in a Cloth Property set, indicated by the locators at the vertices in the set

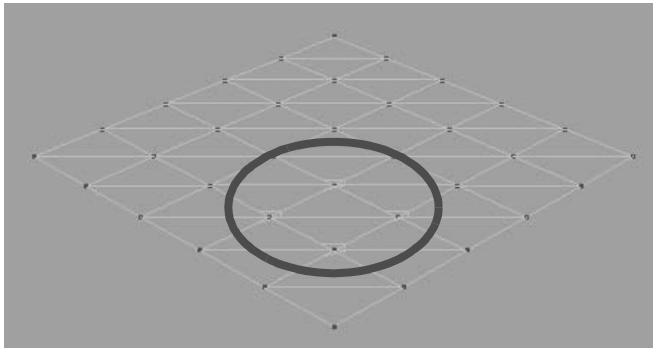

After increasing the Subdivisions on the Cloth Object plane the location of the selected vertices is updated.

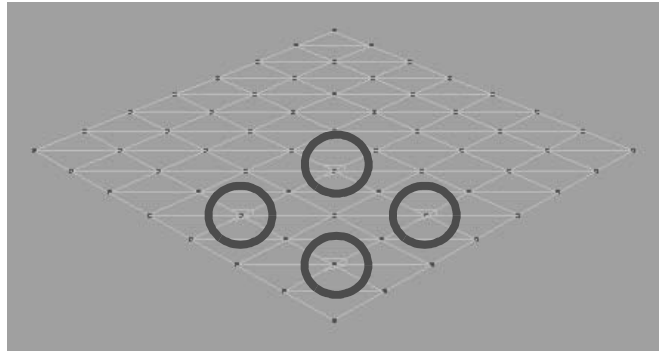

## Cloth UV set

Cloth objects can be assigned a special clothUVset that will be used to assign the UVs on the output cloth mesh. If a special UVset is not specified, Maya Cloth will use the default UVset of the cloth object.

## Painting cloth object properties

Now you can paint cloth properties for cloth objects. You paint cloth object properties the same way you would garments and panels.

For more information, see *Paint properties on cloth* in the online Cloth guide.

## Painting collision object properties



## 11 | Cloth

### > Painting collision object properties

We've added a new tool, the Paint Collision Properties Tool, that you can use to paint collision properties of cloth objects. Specifically, the collision priority for collision objects is now paintable as well as the collision depth map offset. These two attributes are per-vertex maps and therefore cannot be painted on NURBS surfaces.

#### **To paint collision properties of cloth objects**

- 1** Select the collision object to be painted.
- 2** In the Cloth menu, set select Cloth > Paint Collision Properties Tool > .

The Paint Cloth Collision Properties Tool settings window appears.

- 3** Select a Paint Attribute: priorityMap or depthMapOffset. See below for descriptions of the attributes.
- 4** Set the rest of the painting attributes.
- 5** Drag to paint on the surface of the collision object.

For more information, see *Using Artisan brush tools* in the online Paint Effects, Artisan, and 3D Paint guide.

#### **Priority Map**

This is a per-vertex value [0,1]. These values are averaged over a face and added to Collision Priority. The resulting per-face values are used to resolve collisions on a per-face level in the same way that Collision Priority was used on the per-object level.

#### **Depth Map Offset**

This is a per-vertex value [-1,1]. These values are averaged over a face and then used as a percentage offset applied to the calculated depth at that face. This is used to adjust for



situations where the depth map calculation method does not produce perfect results. The effective depth can be painted up or down as needed.

If Depth Map Offset exists and Depth Map Enable is not turned on (see "Per-face collision depth" on page 336), Depth Map Offset is instead applied to Collision Depth. This allows the depth map to be completely manually painted if that is desirable.

## Vertex level cloth properties

You can now assign cloth properties to sets of vertices on a cloth object. Previously cloth properties affected the entire cloth object.

Keep the following things in mind when assigning cloth properties to sets of vertices:

- This works for cloth objects only, therefore you can't add vertex property sets to panels.
- You can't assign vertices to a property that is already assigned to the entire cloth object. Instead, first remove the property from the cloth object and then reassign it as a set.

### **To create a cloth property for a set of vertices**

- 1** Select the desired vertices.
- 2** In the Cloth menu set, select Simulation > Properties > Create Cloth Property.

The selected vertices are automatically assigned to the new property and the cpProperty node is displayed in the Attribute Editor. For more information about cpProperty attributes, see "cpProperty node" on page 331.

## 11 | Cloth

### > Vertex level cloth properties

- 3 Optionally, you can change the Orientation value. The Orientation attribute controls the direction the indicator is facing that's displayed on each vertex that's part of the Cloth Property. This is to help distinguish between vertex property sets.

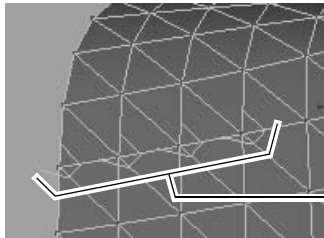

Indicators displayed on each vertex in the Cloth Property

#### **To add vertices to an existing property**

- 1 Select the vertices on the cloth object you want to add.
- 2 Do one of the following:
  - Select Simulation > Properties > *PropertyName*, where *PropertyName* is the name of the desired property.
  - Go to the cpProperty node and in the Set List section, click the *Add selected vertices to set* button.

The vertices are added to the set.

#### **To remove vertices from a property**

- 1 Select the vertices on the cloth object you want to remove.
- 2 Go to the cpProperty node and in the Set List section, click the *Remove selected vertices from set* button.

#### **To replace all vertices in a property**

- 1 Select the vertices on the cloth object you want to be in the set.
- 2 Go to the cpProperty node and in the Set List section, click the *Replace set with selected vertices* button.

## cpProperty node

These are the new attributes in the cpProperty node. For more information, see *cpProperty node* in the online Cloth guide.

### Blend Weights

In the Blend Weights section, use the slider to set a blend weight value for vertices that overlap with other sets. The blend weight value can be between 0 and 1. Zero means the set has no weight, and 1 means the set has full weight. For example, if two overlapping sets both had a blend weight of 1, then the sets property values would be averaged together. But if set A had a blend weight of 0.5 and set B had a blend weight of 1.0, then set A would get half the weight of set B.

### Set List

If the property contains a set of vertices the following buttons are available in the Set List section of the cpProperty node.

#### Select set vertices

This selects the vertices on the cloth object.

#### Add selected vertices to set

This adds the selected vertices to the set of vertices in the cloth property.

#### Replace set with selected vertices

This replaces the set of vertices in the cloth property with the currently selected vertices.

#### Remove selected vertices from set

This removes the selected vertices from the set of vertices in the cloth property.

## 11 | Cloth

### > Removing cloth properties

## Removing cloth properties

Use Remove Cloth Property to sever the connection between the cloth and the solver. The Cloth Property node remains in the Properties submenu.

### To remove a cloth property

- 1 In the Cloth menu set select Simulation > Properties > *PropertyName*, where *PropertyName* is the name of the desired property.
- 2 Select Simulation > Properties > Remove Cloth Property. This removes the selected cloth property.

## Painting tessellation on garments and panels

Using the new paintable attribute, *Coarseness*, you can control the number of triangles (tessellation) on Cloth garments and panels. This does not work for Cloth objects.

In production, the Cloth tessellation is bumped to very fine to catch details in certain areas, allowing the tessellation to be very coarse in areas where you don't care or expect these details. The total number of triangles can be reduced to several times less and the overall performance and memory consumption also improve accordingly. Once *Coarseness* is selected, click the Apply Tessellation button to get the new tessellation result.

*Coarseness* ranges in [0,1] as other paintable attributes and it's used to reduce the tessellation. In general, you would set the max tessellation in the panel node or stitch node, and then use *Coarseness* to reduce the tessellation.

## Visualizing Cloth stress

You can now get visual feedback on areas of the cloth where there's stress, as defined by the cloth solver. The cloth solver monitors the energy of the cloth on a per-vertex basis. With the Stress Visualizer you can see the stress areas reported by the solver.

Once you know the problem area of the cloth, you can frequently prevent the problem by increasing cloth resolution in that area, adding collision constraints, or modifying the collision geometry.

### To show cloth stress

- 1 Select the cloth object or garment.
- 2 In the Cloth menu set select Simulation > Show Cloth Stress.

Make sure the display is in shaded mode (press 5) and the locator nodes are showing (Show > Locators).

- 3 Play the simulation.

At the zero frame there will be no stress because this is the initial state of the cloth. Once you start the simulation you will notice the cloth mesh displaying shaded areas; by default, white represents areas of high stress and black represents areas of low stress.

For descriptions of the attributes in the cpClothStress node, see "cpClothStress node" on page 334.

## 11 | Cloth

> cpClothStress node

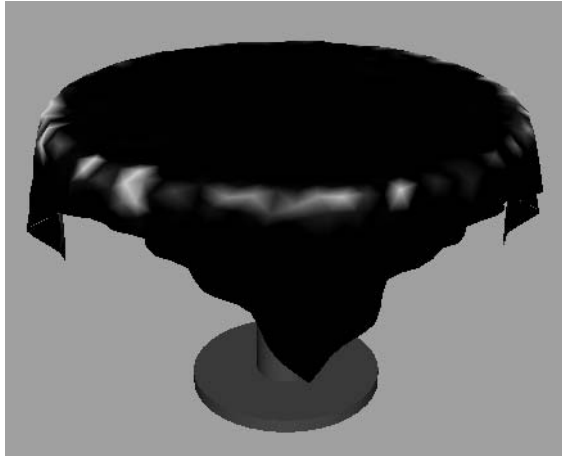

The lighter shading represents areas of high stress on the table cloth.

### To hide cloth stress

- 1 Select the cloth object or garment.
- 2 In the Cloth menu set select Simulation > Hide Cloth Stress.

### cpClothStress node

These are the attributes in the Cloth Stress Visualization section of the cpClothStress node.

#### High Stress Color

This color in the Stress Visualizer represents areas of high stress. The default color is white.

#### Low Stress Color

This color in the Stress Visualizer represents areas of low stress. The default color is black.

## Draw Type

This defines how the stress will be displayed on the cloth object or garment. The drop-down list includes: Default, Shaded, and Numeral.

Default	If you are in Wireframe mode, stress is displayed as Numeral by default; if you are in Shaded mode, stress is displayed as Shaded by default.
Shaded	This applies only when you are in Shaded (as opposed to Wireframe) mode. Areas of stress are represented by colors, as defined by the High Stress Color and Low Stress Color attributes.
Numeral	Areas of stress are annotated with values representing the level of stress. These values are the normalized values from the solver; high areas are close to 1.0 and low areas are close to 0.0.

## Disable Cutoff

This is available only when the Numeral Draw Type is selected. By default this checkbox is turned off. When it is turned on the Cut Off value is disregarded and all stress values are displayed in the Stress Visualizer. This can result in a cluttered display.

## Cut Off

This value is a lower limit on what numerals are displayed in the Stress Visualizer. The default value is 0.5; in this case only stress values of 0.5 and higher are displayed.

## 11 | Cloth

### > Per-face collision depth

#### Stress Scale Factor

In large cloth objects or garments, the normalization of stress values can hide stress. With Stress Scale Factor you can increase or decrease the stress factors to better see the stress. The default is 1.

$$\text{actual} = \text{Stress\_Scale\_Factor} * \text{normalized\_stress\_value}$$

#### Mesh Draw Offset

This is only for the Shaded Draw Type. Use this to better see the stress. The cloth object or garment is drawn n-units closer to or farther from the user in the viewing direction. For example, if the Mesh Draw Offset was 1, but then increased to 2, the cloth would be drawn 1 unit closer in the user's viewing direction. The default is 0.05.

## Per-face collision depth

Maya now has the ability to support per-face collision depth. This can greatly help with cloth sticking to a collision object when the cloth is temporarily pushed inside the object.

Keep in mind the depth map generation is done on demand, which means that if the current depth map is valid for the current collision object, it will not be regenerated. Because depth map generation is a fairly expensive process, it is recommended that the Depth Map Enable attribute be turned on for the first frame of the cloth simulation (this is usually the second frame of the scene) and then turned off for subsequent frames. The generated depth map will be used until Depth Map Enable is enabled again or Collision Depth is changed, in which case Collision Depth will be used for all faces until a new depth map is generated. If the collision object changes radically in shape or size during the animation, turn on Depth Map Enable at any time to create a new depth map based on the current geometry in that frame.



A per-face depth map can be generated automatically and adjusted using the Paint Collision Properties Tool or it can be completely defined using the Paint Collision Properties Tool. (See “Painting collision object properties” on page 327.) To automatically generate a depth map turn on the Depth Map Enable attribute for the collision object before simulating.

For more information, see *Adjust the collision object* in the online Cloth guide.

### Depth Map Enable

When turned on, this scans the collision object and calculates the ideal collision depth for each face on the object. A new depth map is generated for each frame so this can be expensive to use. This attribute is located in the Extra Attributes section of the collision object’s shape node in the Attribute Editor.

### Depth Map Weight

This value is multiplied by the depth map value for each face, resulting in the depth map actually used by Maya. Generally the depth map weight should be left at its default value of 0.3. Raising this above 0.3 will result in a deeper depth map, but increase the possibility of erratic or unstable simulations. Lowering this value will result in a more shallow depth map that may increase the chance of cloth vertices getting stuck in the cloth object. This attribute is located in the Extra Attributes section of the collision object’s shape node in the Attribute Editor.

## Stitch attribute for Cloth constraint

We’ve added a Stitch attribute to the Cloth constraint (Constraints > Cloth). When Stitch is turned on, the Offset, Damping and Stiffness attributes are all disabled so they have no effect. In “Stitch mode” constrained cloth vertices are kept very close (0.1

## 11 | Cloth

### > Mesh constraint improvements

mm away) to the closest point on the target. This has the same effect that a user setting the offset to 0 would desire; however, an offset of zero will still result in a gap between the cloth vertices and the target because the solver considers the cloth to have thickness. This is useful for doing things like attaching a collar to a shirt when modeling clothing with cloth objects.

**Note** To use these new attributes with scene files created before Maya 6, delete the constraint and recreate it to see the new attributes.

## Mesh constraint improvements

We've added an Is Soft attribute to the Mesh constraint (Constraints > Mesh) that, when turned on, constrains cloth to a collision object via springs. The amount of elasticity of the springs is controlled by the Stiffness and Damping attributes, which are also paintable per-vertex.

**Note** To use this new attribute with scene files created before Maya 6, delete the constraint and recreate it to see the new attribute.

## Solver performance improvements

We've improved the Cloth solver performance by providing new Cloth diagnostics, performance controls, and error-reporting. In situations where the solver used to hang, we've improved its ability to detect and react to a hang.

In addition to the above improvements, painting Coarseness controls the number of triangles the cloth solver needs to deal with. If a part of a cloth garment or panel is invisible or its detail

motion is not important, the user can use Coarseness to reduce the triangles in that area to improve the performance. Since Cloth guarantees a smooth transition from coarse to fine tessellation, you can expect the motion to be continuous over the cloth with variant coarseness. For more information, see "Painting tessellation on garments and panels" on page 332.

## Solver hang detection

The solver can now detect instances where it is having difficulties solving a simulation. To control how a solver reacts to situations where there is a probability of it hanging, we've added two new attributes to the cpSolver node. For descriptions of these attributes, see "cpSolver node" on page 339.

### cpSolver node

These are the attributes we added to the cpSolver node.

#### Adaptation Control

This controls what steps the solver can take when it reacts to a situation where it is having difficulty solving a simulation. Select an option from the drop-down list.

Adapt Frame  
Samples And  
Time Step

This gives the solver full control over reaction. The solver will adjust frame samples and time step as it sees necessary to try to resolve the problem.

Adapt Time  
Step

This limits the solver's reaction to adjusting the time step variable.

Stop Solver

This tells the solver to halt and release control to the user. A MEL script is executed if it is defined by the user.

## 11 | Cloth

### > Monitor script parameters

No Action            This tells the solver not to react.

#### monitorScript

Specify the monitor control script, also known as the MEL callback script. If a script is defined and the solver has not been able to resolve a failing simulation, or Stop Solver is specified for Adaptation Control, then the script assigned to this string will be executed. For more information, see "Monitor script parameters."

## Monitor script parameters

To take advantage of the MEL callback, your MEL routine must have the following parameters:

- string \$solverName - This tells the callback the name of the solver that called it.
- int \$failureReason - This tells the callback the reason of failure. See "Reasons for solver failure" on page 341.
- string \$optionString - This string is reserved for future parameters.

These arguments must be the last three arguments of your MEL callback. You can have additional parameters, but they must occur before the above parameters.

Here is a sample callback:

```
global proc myReact( int $stepsBack, string
$solverName, int $reason, string $optionVar )
{
    print ("User defined script called" + $i +
"\n");
    print ("solverNode = " + $solverNode + "\n");
    print ("reason = " + $reason + "\n");
    print ("option = " + $option + "\n");

    float $by = `playbackOptions -query -by`;
```

```

float $curr = `currentTime -query`;
float $min = `playbackOptions -query -min`;
float $max = `playbackOptions -query -max`;

float $theStep = $stepsBack * $by;

if (($curr != $min) &&
    (($curr - $theStep) >= $min) && (($curr -
    $theStep) < $max))
{
    currentTime -edit ($curr - $theStep);
}

// Truncate the cache at the current time.
//
cpSolver -e -deleteRestOfCache;

// Set frame samples to be 1.
//
string $plug1 = ($solverNode + ".frameSamples");
setattr $plug1 1;

// Play forward
play;
}

```

monitorString attribute would equal myReact x where x would equal the number of frames you would want to step back.

## Reasons for solver failure

There can be a few reasons for failure. These reasons equate to the internal fail detector in the solver node.

- 1 **Bad Cutoff** - The cutoff value is a double precision value that represents, approximately, the amount of stress in the cloth. Very large cutoff values are usually an indication of a bad cloth configuration. When the cutoff value exceeds the internal threshold, the fail detector reports the problem and a

## 11 | Cloth

### > Solver diagnostics

response is taken. When `$failReason` equals 1 this implies a large cutoff value occurred and the detector requested that the solver stop.

- 2** Bad Adaptive Step - To solve a single frame the solver makes several steps within that frame to get a solution. Internally the solver has a mechanism for determining how large, or small, of a step it should take to get a solution. This is known as adaptive stepping. If the adaptive step size becomes too small, then the frame may not complete in a reasonable amount of time. The detector looks for cases where the adaptive size is very small and reports this. When `$failReason` equals 2 this implies a very small adaptive step was encountered.

## Solver diagnostics

The solver node monitors solver performance through a series of solver callbacks. These callbacks indicate how well the solver is performing. There are three types of callbacks that represent performance.

- Adaptive Step Notification  
In midstep the solver may decide that it would be appropriate to restart the current step at a smaller time increment (recall that solver takes several steps between frames to compute the output mesh for a given frame). When the solver makes this internal adjustment it notifies the solver node. The solver node records this for analysis. Very small steps are indication the solver is having difficulty finding a solution for the frame.
- Collision Detection Notification  
This callback indicates that collision detection is being performed. The solver tells the solver node the maximum amount of penetration found from a collision.
- Linear Solution Notification

The solver uses a linear solver to determine the output mesh. This callback is invoked several times during this solution process. Encoded in the callback information is a cutoff value. This value roughly indicates the amount of stress in the simulation. Large values indicate poor cloth configuration. These values are recorded by the solver node and used for diagnostic purposes.

### Extracting and interpreting the diagnostic data

You can extract the recorded callback information after a simulation has stopped, either from the completion of playback or from fail detection. To extract information use the following command:

```
cpSolver -wsh "/path/fileName"
```

The solver command extracts the data from the solver node and stores it in the file you specify. A .cbd extension will be added to the name of that file.

The output .cbd file contains four columns.

- The first column is the time instance that the callback data was sampled from. The time corresponds to the current time units.
- The second column is the cutoff parameter returned from the linear solution callback.
- The third column is the maximum penetration value returned from the collision callback.
- The final parameter is the array of adaptive step notifications.

## Advanced Cloth cache editing

With advanced Cloth cache editing in Maya 6 there is now support for multiple caches per node, plus you can copy, blend, and interpolate caches over a range of frames.

## 11 | Cloth

### > Multiple caches

## Multiple caches

You can now have more than one cache per solver and switch between caches dynamically. You can examine different simulations without having to load new caches to view them.

All Cloth cache information is now in the new cpCache node and no longer stored in the cpSolver node. The default cache is attached to the cpSolver node.

Old scene files are automatically handled and converted.

### **To create a new cache**

Select Simulation > Caches > Create Cache.

A new, empty cache is created and it becomes the current cache. You need to put data into the cache either by running a simulation or editing the cache.

### **To switch between caches**

Select Simulation > Caches and then select the desired cache.

Each solver can have multiple caches, but solvers cannot share caches.

## Editing caches

With multiple caches you can now take parts of different simulations and blend or interpolate them. This will reduce the number of simulations needed to produce a good cloth simulation.

To edit a cache you need the following:

- an edit operation (copy, blend, interpolate)
- a collection of source cache segments
- a target cache segment



An edit operation takes a series of source cache segments and produces a result in the target cache segment. A cache segment is made up of a cache node, range, and, optionally, a weight. Cache segments indicate what part of a cache to manipulate in the operation. The weight specifies how much of the cache segment you want to keep. In an operation all of the cache segments are normalized so their sum equals one.

The operation acts on the cache segments and combines the results into a target cache segment, which again specifies a cache node and a range, but not a weight.

Cache segments can start at different frames, but cannot be different in length (duration). In non-linear editing this is known as scaling and is not currently supported.

If a target cache segment is not specified then the default target is the same as the first source cache segment.

### **To interpolate cache data**

- 1** Select the cloth and then select the time range (shift-drag in the Time Slider).
- 2** Select Simulation > Interpolate Cache. This interpolates the current cache between the selected time range.

**Note** You can also interpolate cache data using the Cache Editor. With the Cache Editor you can specify the type of interpolation as either linear or sine. See “Using the Cache Editor.”

### **Using the Cache Editor**

Using the Cache Editor you can interpolate, blend or copy cache frames from different simulations in the same solver. This reduces the number of simulations needed to produce a good cloth simulation.

## 11 | Cloth

### > Editing caches

#### **To open the Cache Editor**

Select Simulation > Cache Editor.

The Cache Editor window appears. For descriptions of the options in the Cache Editor window, see "Simulation > Cache Editor" on page 348.

#### **To interpolate caches using the Cache Editor**

- 1** Select Simulation > Cache Editor. The Cache Editor window appears.
- 2** Click the Add Cache Segment button. This adds a panel in the Cache Editor window for you to set the options for the source cache segment. You can only have one source cache segment when interpolating.
- 3** Set the options for the source cache segment.
- 4** Select a Target Cache from the drop-down list.
- 5** Specify a Target Range of frames.
- 6** Select *interpolate* from the Operation drop-down list.
- 7** Select an Interpolation Type from the drop-down list.

##### Linear

Specifies linear interpolation from the start of a cache segment range to the end.

##### Sine

Favors values close to the start and end of the cache segment range and follows a more linear interpolation in the middle.

- 8** Click Apply or Apply and Close.

#### **To blend caches using the Cache Editor**

- 1** Select Simulation > Cache Editor. The Cache Editor window appears.

- 2** Click the Add Cache Segment button. This adds a panel in the Cache Editor window for you to set the options for the source cache segment. Add as many source cache segments as you need.
- 3** Set the options for each source cache segment, including the blend weight. Each range must be the same duration.
- 4** Select a Target Cache from the drop-down list.
- 5** Specify a Target Range of frames. The range must be the same duration as the source cache segments.
- 6** Select blend from the Operation drop-down list.
- 7** Click Apply or Apply and Close.

**To copy frames between caches using the Cache Editor**

- 1** Select Simulation > Cache Editor. The Cache Editor window appears.
- 2** Click the Add Cache Segment button. This adds a panel in the Cache Editor window for you to set the options for the source cache segment. You can only copy one segment at a time.
- 3** Set the options for the source cache segment.
- 4** Select a Target Cache from the drop-down list.
- 5** Specify a Target Range of frames. The range must be the same duration as the source cache segment.
- 6** Select copy from the Operation drop-down list.
- 7** Click Apply or Apply and Close.

## Simulation > Cache Editor

This opens the Cache Editor window. Use this to blend, interpolate, or copy frame ranges from different caches into a target cache. For more information see "Using the Cache Editor" on page 345. These are descriptions of the options in the Cache Editor window.

### Add Cache Segment

Click this button each time you want to add a source cache segment. Then set the source cache segment's options.

Cache	Select the cache for the source cache segment.
Range	Specify a range of frames for the source cache segment.
Weight	Specify a weight if you are blending cache segments.

### Target Cache

Select a target cache from the drop-down list.

### Target Range

Specify the start and end frame in the target cache. The duration of this frame range must be the same as the source range(s). For example, the source range could be frames 1 to 5 and the target range could be frames 21 to 25.

### Operation

Select an editing operation from the drop-down list.

Interpolate	Replaces the selected cloth particles' positions between the specified Target Range in the Target Cache with computed values between the values at Start Frame and End Frame of the Source Cache. The
-------------	---

interpolation type determines how the values are calculated. For instance, sinusoidal interpolation favors values that are close to the range boundaries and acts more like linear interpolation in the middle. Interpolation only works with a single Source Cache.

**Blend** Based on a specified blend weight, combines specified equal duration frame ranges from different simulations into the target cache segment at the specified range. Set the blend weight in the source cache segment options. Weighting values are normalized so the sum of cache segment weights equals 1.0. The source and target ranges can be in different caches.

For example, combine frames 1 to 5 of one simulation and frames 6 to 10 of another simulation into frames 21 to 25 of the target simulation.

**Copy** Copies the specified frame range in the source cache segment to the specified frame range (of equal duration) in the target cache segment.

### Interpolation Type

If you select interpolate as your editing operation, you'll need to select a type of interpolation.

**Linear** Specifies linear interpolation from the start of a cache segment range to the end.

**Sine** Favors values close to the start and end of the cache segment range and follows a more linear interpolation in the middle.

## **11 | Cloth**

> Simulation > Cache Editor

# 12

# MEL

## Changes to MAYA\_SCRIPT\_PATH

In Maya 6 we made some changes to how Maya searches for scripts in the search path (MAYA\_SCRIPT\_PATH).

We have implemented caching of the script path in Maya. That means Maya searches the script path once and remembers what it saw for use in future searches. This was previously introduced in Maya 5.0, where it was activated using the MAYA\_CACHE\_SCRIPT\_PATH environment variable that you could set in your Maya.env file. In Maya 6, the script path is always cached.

Keep in mind new scripts that are added to your script path will not be picked up automatically by a running copy of Maya. You need to tell Maya to re-scan the script path to find new scripts. To do this use the new `rehash` command.

The caching of the script path helps with the startup time of Maya, especially for users that have network drives in their script paths.

## New and improved commands

### General

- We've added a new `rehash` command to have Maya re-scan the script path to find new scripts. For more information, see "Changes to MAYA\_SCRIPT\_PATH."
- There is a new `webBrowser` command that creates web browser control. For command and flag details, see "New webBrowser command" on page 363.

## 12 | MEL

> General

- There are several new MEL procedures to support customizing the Optimize Scene Size command. For details see “Customizing Optimize Scene Size” on page 360.
- We’ve added a new `imfPlugins` command to query imf plugins.
- `binMembership` lets you categorize nodes for sorting in the Hypershade.
- The `scriptJob` command now has two new events. You can listen to Undo and Redo.
- The `duplicate` command now has a new `instanceLeaf` flag to duplicate with an instanced hierarchy.
- The `rand` (random number generator) command can now generate multiple random number streams. This is useful for dynamics and other applications. For more information, see “Multiple random number streams.” We also added two new `rand` methods: `randstate` and `delrandstr`.
- We’ve added a `-r/-recursive` boolean flag to the `ls` command. When `-recursive true` is used `ls` searches all namespaces for objects matching the given string. When `-recursive false` is used `ls` behaves as it did before and only searches the current namespace.
- We’ve added the flag `-dp/-dagPath` to the `reference` command. This flag causes reference command queries to return the full dag path of all nodes (new functionality). Without this flag the reference command queries return node names (old behavior).
- We added the flag `-as/-asString` to the `getAttr` command. This flag is only valid for enum attributes. It allows you to get the attribute values as strings instead of integer values.



## New flags for the file command

- We created some new commands and added a few flags to the file command relating to loading file references. For details see "Selective load of references" on page 358.
- We added a `-preserveReferences` flag to the `file` command to allow references to be preserved during file import/export. The flag can only be used for import/export flags.
- We added a `-lastTempFile` flag to the `file` command. When queried, this flag returns the temp file name used during file save. The temp file will be left in the same directory as the intended file name if the save fails.
- We added an `-errorStatus` flag to the `file` command. This queries the error status of the last file read. It returns true if an error occurred during the last file read.
- We added a `-resetError` flag to the `file` command.
- We added an `-exportAnimFromReference` flag to the `file` command. Export the main scene animation nodes and animation helper nodes from all referenced objects. This flag, when used in conjunction with the `-rfn/referenceNode` flag, can be constrained to only export animation on nodes from the specified reference file. For more information, see "New MEL flags for importing and exporting animation" on page 179.
- We also added an `-exportSelectedAnimFromReference` flag to the `file` command. Export the main scene animation nodes and animation helper nodes from all referenced objects. This flag, when used in conjunction with the `-rfn/referenceNode` flag, can be constrained to only export animation on nodes from the selected nodes of a specified reference file. For more information, see "New MEL flags for importing and exporting animation" on page 179.

## Modeling

- `softMod` gives you control over the new soft modification feature. See “Soft Modification Tool and Deformer” on page 59.
- We’ve made changes to the `makeIdentity` and `polyNormalPerVertex` commands. For details of the changes, see “Freeze Transformations (makeIdentity)” on page 98 and “polyNormalPerVertex” on page 100.

## Animation

- You can now bake referenced animation data using the `bakeResults` and `bakeSimulation` commands.
- We added a new `retarget` command for animation.
- We updated flags for `clipSchedule`. The `-cycle` flag is now obsolete and we added the following flags: `-preCycle`, `-postCycle`, `-sourceStart`, and `-sourceEnd`.
- You can now output single frames of your animation to Playblast using the new `-frame` flag for the `playblast` command. For example:  

```
playblast -frame 1 -frame 4 -frame 7
```

outputs frames 1, 4, and 7 of your current animation to Playblast. The `-frame` flag overrides any `-startFrame/`  
`-endframe` flags.
- You can change the color of your animation curves. For more information, see “Example MEL procedure for customizing the color of multiple animation curves” on page 184.

## Painting

- `pxfstrokes` lets you dump Paint Effects stroke information to a file.

- The Paint Scripts Tool now supports stroke direction and stamp position. For details see “Paint Scripts Tool improvements” on page 360.

## Rendering

- We’ve added a new `psdExport` command that exports the Photoshop file layer sets into different file formats.
- We’ve added a new `psdTextureFile` command that creates a Photoshop file with UVSnap shot image and the layer set names as the input.
- We’ve added the `convertLightmap` command for baking and prelighting with mental ray for Maya.
- We’ve added the `MayaToMr` command, which provides access to most functionality of the mental ray for Maya plug-in, including .mi file export, preview and batch rendering, network rendering and shader management.

## Cloth

- We made several improvements to the `cpProperty` command to support per-vertex property sets.
- The `cpCache` command is a new cloth command for manipulating cloth caches.
- We’ve added a new `-uvs/getUVs` flag to the `cpSolver` command. The flag will accept cloth/panel pair or simply a cloth object named followed by an empty string. For example,  

```
cpSolver -uvs cloth1 ""
```

will return all of the solver UVs for cloth1. The command  

```
cpSolver -uvs cloth1 panel1
```

The UV values are 2d values that the solver uses to compute bending and shearing forces on the cloth.

## 12 | MEL

### > Converting between vector and float arrays

## Converting between vector and float arrays

You can now convert between vector and float array types in MEL. Previously in MEL, in order to convert between a vector and float array, you had to manually assign each component, for example:

```
float $a = {0.0, 1.1, 2.2};  
vector $v;  
$v.x = $a[0];  
$v.y = $a[1];  
$v.z = $a[2];
```

And the converse:

```
$a[0] = $v.x;  
$a[1] = $v.y;  
$a[2] = $v.z;
```

MEL now supports the ability to directly convert between these two types, for example:

```
$v = $a;  
$a = $v;  
$a = <<1.1,2.2,3.3>>;  
$v = {1.1,2.2,3.3};  
takesAfloatArray( $v );  
takesAfloatArray( <<1,2,3>> );  
takesAvector( $a );  
takesAvector( {1.1,2.2,3.3} );
```

## Script node improvements

The script node has a new trigger that fires when the current time changes.

## Multiple random number streams

You can now have multiple random number streams in Maya. Each stream is specified by a user-defined name. There is also the concept of a default stream (named “default”) that is used for random number calls that don’t use streams.

To support multiple random number streams, the existing MEL random functions have been enhanced to accept a string parameter as a new optional first argument. By specifying the name of a stream, Maya will use the specified stream when generating the random number, creating the stream first if non-existent. Whenever a new stream is created, it is seeded with a fixed internal default (the same seed the default stream is created with).

The variants of the MEL random number functions are:

```
string $stream;
floatORvector $range, $max, $result;
int $seedval;

$result = rand( [$stream,] $range [, $max] );
$result = sphrand( [$stream,] $range );
$result = gauss( [$stream,] $range );
seed( [$stream,] $seedval );
```

One convenience method is provided:

```
int $istream;
$result = rand( $istream, $min, $max );
```

This method allows an integer to be used as the stream name and is useful for simple particle work. For example, you can easily use the particleID without having to construct a string. Internally, this function converts \$istream to a string when selecting the random number stream.

## 12 | MEL

### > Selective load of references

To manage multiple random number streams, a new function has been added so you can delete streams by name. The function accepts a wildcard string; currently only one "\*" character is supported (for example, `delrandstr("p*.15")` will delete all stream names which match the pattern, and `delrandstr("*")` will delete everything. If an attempt to delete the default stream is made, that request is silently ignored. The new function returns the number of streams that were deleted.)

```
int $count = delrandstr( $stream );
```

## Selective load of references

In Maya 6 you now have control over which references, at all levels in the hierarchy, you want to load with your file upon opening.

For more information on the workflow and concepts of selective load of references, see "Selective file loading" on page 28.

We've added the following MEL commands and flags to support selective loading of references.

```
file -o -buildLoadSettings "file.ma";
```

`-buildLoadSettings` builds settings of the current state of referenced files, whether they were loaded or not loaded upon saving last time.

These "Selective Load Settings" can be edited using the Preload Reference Editor (see "Preload Reference Editor" on page 30). Then to open the file with these "Selective Load Settings" use the following command:

```
file -o -loadPreferences "implicitLoadSettings" "file.ma";
```

If you want to open the file with the default settings, use the following command:

```
file -o "file.ma";
```

This is the equivalent of File > Open.

If you wish to hook the selective preload functionality into your MEL scripts see the command documentation (Help > MEL Command Reference) for the `selLoadSettings` command and the `file -buildLoadSettings` flag.

## Additional information

- We also added the `-referenceDepthInfo` flag to the `file` command. This flag is used to store preferences associated with a Maya ascii file (.ma). This flag is only useful during file I/O so users should not have any need to use this flag themselves.
- We've also added the following three new flags to the `file` command:
  - `-unresolvedName`
  - `-shortName`
  - `-withoutCopyNumber`These flags are used to format the file paths returned by `file` command queries.
- We added a new command `preloadRefEd` that opens the Preload Reference Editor window. This window is used for editing which references you want to be loaded. See "Selective file loading" on page 28.
- We added a new command `selLoadSettings`, which is called by Maya to edit the "Selective Load Settings" when you make changes in the Preload Reference Editor window. We've also provided two flags for this command: `-unresolvedName` and `-shortName`. These flags are used to format the file paths returned by `selLoadSettings` command queries.

## Paint Scripts Tool improvements

We added new flags to obtain direction and brush center information from the Paint Scripts Tool (formerly known as the Script Paint Tool). You can obtain the direction of paint stroke or stamp position in the SetValueCommand and use them. These flags have to be set in InitializeCommand of the script. (See the `artUserPaintCtx` command.) For more information, see *Write MEL Scripts for the Paint Scripts Tool* in the online Paint Effects, Artisan, and 3D Paint guide.

`-dt/directionType` string

This flag indicates whether the (u,v,w) stroke direction should be sent to SetValueCommand. The possible values for this are none, screenV (a vector in screen space) or worldV (a vector in world space). The default is none. For projection painting, both screenV and worldV return a vector in screen space. The direction option is not supported for reflection painting. The third value(w) will be invalid if the user has requested direction as screen vector.

`-sp/stampPosition` string

This flag indicates whether the (spX, spY, spZ) stamp position should be sent to SetValueCommand. The possible values for this are none, local or world. The default is none.

## Customizing Optimize Scene Size

For more details on the changes to Optimize Scene Size in this release, see "Optimize scene size" on page 37.

We have changed the Optimize Scene Size function to accommodate additional optimization steps that can be added at runtime. The new MEL procedure `cleanUp_AddUserCleanUp()` can be used to add any number of new optimization steps.

The syntax to use the command is as follows:



```
global proc cleanUp_AddUserCleanUp( string $name, string $label, int
$default, string $cmd )
```

where:

- `$name` – an internal name to identify this optimization
- `$label` – a user-friendly name for the optimization to be presented in the Optimize Scene Size dialog box
- `$default` – whether or not the optimization should be enabled by default (1=true, 0=false)
- `$cmd` – the MEL code to run when the optimization is executed

For example, execute the following command:

```
cleanUp_AddUserCleanUp( "deleteCustomShaders", "Remove mr Custom Shaders",
1, "deleteAllCustomShaders()" )
```

This adds the specified new optimization operation to the Optimize Scene Size dialog box (you must close and reopen the dialog box for the change to take effect).

## 12 | MEL

### > Customizing Optimize Scene Size

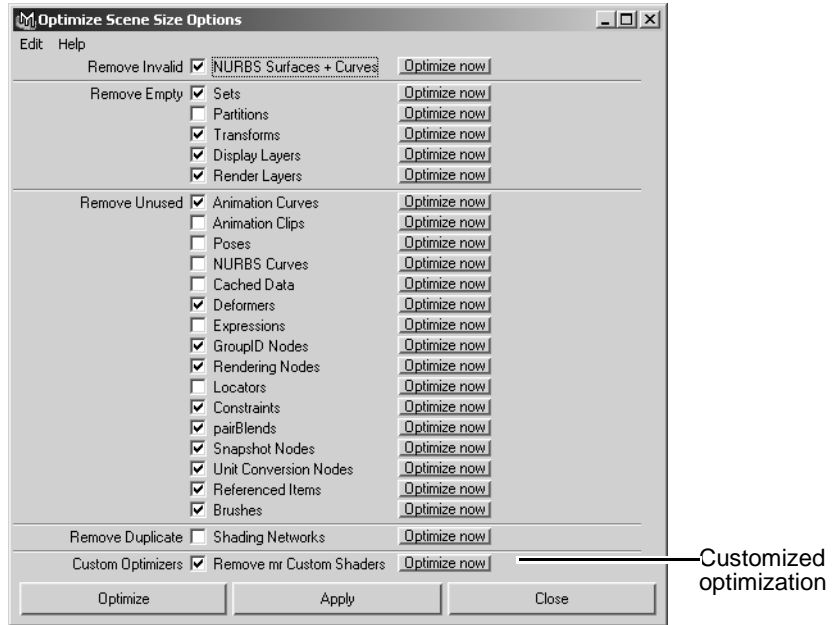

A new initialization routine, `cleanUp_RegisterUserCleanUps()`, is provided to allow you to automatically add multiple custom optimizations at startup.

This sample optimization is implemented by the `deleteAllCustomShaders()` procedure. The following example is an implementation of this procedure, which deletes all mental ray custom shading nodes. Please see the Maya Help version of this document (Help > Maya Help > What's New in Maya > MEL) for the full script.

This procedure makes use of several new MEL utility functions to provide progress reporting and interruptibility:

- `cleanUp_StartProgress()` – initializes the progress bar

- `cleanUp_SetProgress()` – updates the progress bar and checks for user interrupt
- `cleanUp_EndProgress()` – finalizes the progress bar
- `cleanUp_Summary()` – records summary information for display at the end of the optimization

A facility is also provided for automatically adding custom optimization steps. When the Optimize Scene Size feature is first invoked, it calls a routine called

`cleanUp_RegisterUserCleanUps()` (from `cleanUp_RegisterUserCleanUps.mel`) to allow initialization of custom steps. By modifying this function, you can ensure that a specific set of custom optimizations are always available. Please see the Maya Help version of this document (Help > Maya Help > What's New in Maya > MEL) for the full script.

## New webBrowser command

The `webBrowser` command allows you to create a UI control which contains a web browser. This allows you to place a web browser within a panel that you create. For example, a custom panel you create could contain a `webBrowser` control which displays help information, or you could choose to implement parts of your GUI using HTML; or you could create a panel with an embedded web browser that navigates to `www.alias.com`.

For additional information, in Maya select Panels > Panel > Web Browser. This displays a web browser panel containing information about what the Alias Web Browser is, how it's different from other browsers and how to set up browser preferences.

`webBrowser [flags] [webBrowserName]` returns the full path name to the control.

The flags for the `webBrowser` command are:

## 12 | MEL

### > New webBrowser command

`-url/openURL string`

(C,E) URL to open in the web browser.

`-bk/back`

(E) Navigate to the previous page in the session history.

`-fwd/forward`

(E) Navigate to the next page in the session history.

`-hm/home`

(E) Navigate to the home page.

`-rl/reload`

(E) Reload last page.

`-st/stop`

(E) Stop current page loading process.

`-ucc/urlChangedCb`

(C,E,Q) An optional MEL callback. If set, it will be called whenever the current URL changes. The MEL callback should take one string that will contain the new URL. This is used by Maya to keep the url location bar up to date.

For the webBrowser command the flags `-url`, `-bk` and `-fwd` can be queried. In a query the `-url` flag will return the current URL. For `-bk` and `-fwd` it will return true/false depending if there are URLs to go forward/back to.

There is also a new `webBrowserPrefs` command that can be queried or edited. Use it to manage the embedded browsers preferences. There are several preferences that can be set, but the most common ones can be set in the Preferences window in the Web Browser category. (Window > Settings/Preferences > Preferences)

# 13 Translators

## Image file support

Maya now supports the following image types:

- *png* (Portable Network Graphics) image type, which allows 24-bit color and lossless compression. For more information on PNG, see [www.libpng.org/pub/png/](http://www.libpng.org/pub/png/).  
You can use this image type wherever you would import or save an image from Maya (for example, from the Render View, in FCheck, etc.)
- *dds* (Direct Draw Surface) image type, used by Microsoft's Direct X. Many games on Windows use this file format. Maya supports importing of any of the five types of DDS encoding (DXT1 - DXT5), and allows export (UV snapshot, render, etc.) of a DXT1 DDS file with full alpha information.
- *rla*. We've added the ability to render to RLA format on Mac OS X. This format supports embedded depth that can be used in compositing packages such as Adobe After Effects.

---

**Note** Maya was not previously able to support 8-bit file textures; you can in Maya 6 by using the DDS format.

---

## DWG translator improvements

We have added support for AutoCAD 2004 DWG files, and improved the speed and robustness of the translator.

## New IGES import/export options

The following IGES import options are available when the IGES translator plug-in is loaded and IGES is selected from the File Type drop-down list of the File > Import >  dialog box.

## 13 | Translators

### > New IGES import/export options

#### Default Trim Curves

Select Parameter Space trimming (curves defined in the parameter space of the surface) or World Space trimming (curves defined in world space of the model). The default is to use parameter space trimming.

IGES Trim Space. In IGES a trimmed surface can specify its preferred trimming method, either world space or parameter space. Choosing this option tells Maya to use whatever method is preferred in the file.

#### Scale Factor

Scales all imported geometry by a common factor. This allows very large scenes to be viewed more easily.

**Note** IGES files often contain geometry that is very large. In order to view this geometry properly, the Scale Factor can be used to scale it down. Otherwise, in the viewing window, select View > Frame All to frame your selection, and if the geometry does not appear, it is beyond the camera's rear clipping plane. Select View > Camera Attribute Editor and set the "Far Clip Plane" to a value sufficiently large such that the geometry is visible.

#### Level Mapping

Controls whether layers from an IGES file are imported. The default is to import layers.

The following IGES export options are available when the Iges translator plug-in is loaded and IGES is selected from the File Type drop-down list of the File > Export Selection >  or File > Export All >  dialog box.

### Scale Factor

Determines the factor by which the resulting geometry in the IGES file is scaled upon export (default: 1.0000).

## STL import

Maya can now import STL (Stereo lithography Tessellation Language) files. The STLImport plugin must be loaded in order to import STL files.

In the Import options for STL, you can set the Merge vertices with tolerance setting. This specifies the maximum allowable distance between vertices to be merged together.

When importing large STL files, it is often beneficial (both in terms of the time it takes to import a file and the size of a file) to merge vertices that are sufficiently close together into one vertex to condense the data without any noticeable sacrifice to the integrity of the data.

Moreover, the STL importer will create the same vertex several times if Merge vertices with tolerance is left unchecked. This will occur three times for every face in the mesh, generating a lot of unnecessary data.

## IgesDxftoMaya removed

The functionality of this translator is now in the IGES and DXF/DWG translator plug-ins. Please see the online Translator guide.

## OpenFlight on Mac OS X

OpenFlight is now supported on Mac OS X.

## **13 | Translators**

> StudioImport on Mac OS X

### **StudioImport on Mac OS X**

StudioImport is now supported on Mac OS X.



# 14 API and DevKit

## API

### Improvements to the Maya API

Many changes have been made to the API for Maya 6. We have added new classes and additional functionality to existing classes. Also, we have included many new examples that demonstrate the new functionality.

- ❖ "New classes and header files" on page 369
- ❖ "Changes to existing classes" on page 370
- ❖ "Examples of new plug-in functionality" on page 386
- ❖ "Other significant changes" on page 388
- ❖ "Compiler requirements" on page 389

### New classes and header files

#### Classes

##### **MFnRotateManip**

Lets you access the built-in Maya rotate manipulator.

##### **MFnScaleManip**

Lets you access the built-in Maya scale manipulator.

##### **MObjectHandle**

Lets you query the validity state of an MObject.

##### **MObjectSetMessage**

Lets you register callbacks with set specific event types.

## 14 | API and DevKit

### > Headers

#### MPolyMessage

Lets you register callbacks for poly messages. Currently, you can use this class to listen to component id changes for vertices, edges and faces.

#### MProgressWindow

Lets you access progress window functionality.

#### MTrimBoundaryArray

Lets you maintain an array of edges on a trim boundary. This class is required by the new `MFnNurbsSurface` functionality.

#### MUIntArray

Lets you maintain an array of unsigned integers. This class is required by the new `MPolyMessage` class.

#### MUserEventMessage

Lets you post and respond to user defined messages.

### Headers

#### MStream

Lets you centralize the inclusion of the `fstream` header.

## Changes to existing classes

#### M3dView

You can now access the renderer name and enhanced refresh options in this class.

```
RendererName getRendererName(MStatus *ReturnStatus /*  
= NULL */) const;
```

Returns the name of the current renderer that is being used in the scene view.

```
enum RendererName {  
    // Equivalent to when the renderer name is "base_OpenGL_Renderer"  
    when queried from the "modelEditor" command  
    kDefaultQualityRenderer,  
    // Equivalent to when the renderer name is  
    "hwRender_OpenGL_Renderer" when queried from the "modelEditor" command  
    kHighQualityRenderer  
};
```

Enum used in `getRendererName()` method that describes which renderer is being used.

```
bool wireframeOnlyInShadedMode(MStatus *ReturnStatus /  
* = NULL */) const;
```

Returns true if you are in shaded mode but only displaying wireframe.

```
MStatus refresh( bool all, bool force, bool offscreen  
);
```

This method lets you control whether or not the offscreen buffer is redrawn.

```
MStatus refresh( MPxGlBuffer &buffer, bool offscreen  
);
```

This method lets you control whether or not the offscreen buffer is redrawn.

## MAnimControl

You can now get and set the animation start and end times.

```
static MTime animationStartTime();
```

Returns the animation start time.

```
static MTime animationEndTime();
```

Returns the animation end time.

## 14 | API and DevKit

### > MDagMessage

```
static MStatus setAnimationStartTime( MTime  
newStartTime );
```

Sets the animation start time.

```
static MStatus setAnimationEndTime( MTime newEndTime  
);
```

Sets the animation end time.

```
static MStatus setAnimationStartEndTime( MTime  
newStartTime, MTime newEndTime );
```

Sets the animation start and end times.

## MDagMessage

You can now listen to instance added and instance removed messages. The enum `DagMessage` now has two new items for use with the `addDagCallback()` method:

```
kInstanceAdded,  
kInstanceRemoved
```

```
static MCallbackIdaddInstanceAddedCallback( void (*func)( MDagPath  
&child, MDagPath &parent, void * clientData ), void * clientData = NULL,  
MStatus * ReturnStatus = NULL );
```

Lets you creates a callback that listens for all instance added messages.

```
static MCallbackIdaddInstanceAddedCallback( MDagPath &dagPath, void  
(*func)( MDagPath &child, MDagPath &parent, void * clientData ), void *  
clientData = NULL, MStatus * ReturnStatus = NULL );
```

Lets you create a callback that listens for new instances of the node described by the `dagPath`.

```
static MCallbackIdaddInstanceRemovedCallback( void (*func)( MDagPath  
&child, MDagPath &parent, void * clientData ), void * clientData =  
NULL, MStatus * ReturnStatus = NULL );
```

Lets you creates a callback that listens for all instance deleted messages.

```
static MCallbackIdaddInstanceRemovedCallback( MDagPath &dagPath, void
(*func)( MDagPath &child, MDagPath &parent, void * clientData ), void
* clientData = NULL, MStatus * ReturnStatus = NULL );
```

Lets you create a callback that listens to the removal of instances described by the dagPath.

## MDagPath

There is now better dag path support for when you have multiple shapes underneath a transform. The existing `extendToShape()` method fails under this case.

```
MStatus extendToShapeDirectlyBelow( unsigned int index
);
```

Extends to the shape directly below that is specified by the index.

```
MStatus numberOfShapesDirectlyBelow( unsigned int& );
```

Returns the number of shapes directly below the transform.

## MFloatVector and MVector

We now have support for the one vector.

The `MFloatVector` class now has a constant for the one vector `<1.0,1.0,1.0>`. For example:

```
static const MFloatVector one;
```

The `MVector` class now has a constant for the one vector `<1.0,1.0,1.0>`. For example:

```
static const MVector one;
```

## MFnArrayAttrsData

You can now extract specific data types from array attributes data.

```
MVectorArray getVectorData( const MString attrName,
MStatus *ReturnStatus = NULL);
```

## 14 | API and DevKit

### > MFnCamera

Returns an `MVectorArray` of the data the function set is operation on.

```
MDoubleArray getDoubleData( const MString attrName,  
MStatus *ReturnStatus = NULL);
```

Returns an `MDoubleArray` of the data the function set is operation on.

```
MIntArray getIntData( const MString attrName, MStatus  
*ReturnStatus = NULL);
```

Returns an `MIntArray` of the data the function set is operation on.

```
MStringArray getStringData( const MString attrName,  
MStatus *ReturnStatus = NULL);
```

Returns an `MStringArray` of the data the function set is operation on.

## MFnCamera

You can now specify the context when accessing the camera projection matrices.

```
MFloatMatrix projectionMatrix( MDGContext& context, MStatus *  
ReturnStatus = NULL ) const;  
MFloatMatrix postProjectionMatrix( MDGContext& context, MStatus *  
ReturnStatus = NULL ) const;
```

A new parameter has been added to this class that lets you specify the context.

## MFnClip

You can now create pre-cycles when creating clips.

```
MObject createInstancedClip ( MObject& sourceClip, const MTime& start,  
MDGModifier& dgMod, MStatus * ReturnStatus = NULL, bool absolute = 1,  
double postCycle = 0.0, double weight = 1.0, double scale = 1.0, double  
preCycle = 0.0 );
```

This method has been modified. The previously used `cycle` parameter has now been renamed to `postCycle` and a new `preCycle` parameter has been added.

```
double getPreCycle(MStatus *ReturnStatus = NULL);
```

This method returns the value of this clip's pre-cycle attribute.

```
double getPostCycle(MStatus *ReturnStatus = NULL);
```

This method returns the value of this clip's post-cycle attribute.

```
MStatus setPreCycle(double cycle, MDGModifier* mod = NULL);
```

This method sets the pre-cycle value for the clip.

```
MStatus setPostCycle(double cycle, MDGModifier* mod = NULL);
```

This method sets the post-cycle value for the clip.

## MFnDagNode

You can now create instances more easily with this method.

```
MStatus addChild( MObject & child, unsigned int index = kNextPos, bool keepExistingParents = false );
```

This method has a new `keepExistingParents`. When `keepExistingParents` is set to `true`, you can create instances.

```
bool inModel( MStatus * );
```

This method allows you to determine if a dag node has been added to the Maya model.

## MFnDirectionManip

You can now set the direction for this manipulator.

```
MStatus setDirection(MVector &direction);
```

This method lets you set the direction of the manipulator.

## 14 | API and DevKit

> MFnDoubleIndexedComponent

### MFnDoubleIndexedComponent

We now support `MFn::kMeshVtxFaceComponent` objects within this class.

### MFnFluid

We now make it easier to get the velocity grid size and support new index methods into the fluid.

```
MStatus velocityGridSizes( int & xsize, int & ysize, int & zsize );
```

This method returns the number of elements in the velocity grid.

```
int index( int xi, int yi, int zi, int xres, int yres, int zres );
```

This method is used to find the index of a cell given the X, Y and Z resolutions.

```
void index( int ai, int xres, int yres, int zres, int & xi, int & yi, int & zi );
```

This method is used to find the coordinates of a cell given the index, and the X, Y and Z resolutions.

### MFnFreePointTriadManip

You can now set the point associated with this manipulator.

```
MStatus MFnFreePointTriadManip::setPoint(const MPoint& pointValue)
```

This method lets you set the point manipulator value to a specified vector.

### MFnManip3D

You can now delete base manipulators with the following method:

```
MStatusMFnManip3D::deleteManipulator(MObject& manip);
```



This method lets you delete manipulators that were created using base manipulator create() methods.

## MFnNurbsCurve

There is now a new creation method and the ability to reverse a curve in this class.

```
MObject create( const MObjectArray& sources, MObject & parentOrOwner =  
MObject::kNullObj, MStatus* ReturnStatus = NULL );
```

This method creates a single curve that represents all the curves in the MObjectArray.

```
MStatus reverse(bool constructionHistory = false);
```

This method reverses a curve's direction.

## MFnNurbsSurface

You can now use trim boundaries in this class.

```
MStatus getTrimBoundaries(MTrimBoundaryArray& result, unsigned region,  
bool paramEdge = true);
```

This method returns all trim boundaries of a region on the surface.

```
MStatus trimWithBoundaries(const MTrimBoundaryArray& mBoundaries, bool  
flipNormal = false, double e_tol = 1e-3, double pe_tol = 1e-5);
```

This method trims the surface with given trim boundaries.

## MFnParticleSystem

You can now access particle id information in this class.

```
void particleIds( MIntArray& ) const;
```

Returns an array of particle identifiers at the start of the time step. The array of particle ids is correlated with the other per-particle arrays returned by this class.

## 14 | API and DevKit

### > MFnPlugin

## MFnPlugin

We now have better support for creation and deletion scripts in batch mode. In addition, you can find out if a node has been registered.

```
MStatus registerUI(const MString & creationProc, const MString &
deletionProc, const MString & creationBatchProc = "", const MString &
deletionBatchProc = "");
```

Two new parameters have been added to this method. You can now set a creation and deletion procedure to be run if the plug-in is loaded in batch mode.

```
static bool isNodeRegistered( const MString& typeName );
```

This method queries if the given `typeName` has been registered.

## MFnSubd

We have added new support for evaluating positions and normals. In addition, access to the cubic spline of certain faces is now provided.

```
MStatus evaluatePosition( MUInt64 polyId, double u, double v, bool
uvNormalized, MPoint& ) const;
```

This method evaluates the surface position at the given parameter point on the polygon.

```
MStatus evaluateNormal( MUInt64 polyId, double u, double v, bool
uvNormalized, MVector& nrml ) const;
```

This method evaluates the surface normal at the given parameter point on the polygon.

```
MStatus evaluatePositionAndNormal( MUInt64 polyId, double u, double v,
bool uvNormalized, MPoint& pos, MVector& nrml ) const;
```

This method evaluates the surface position and normal at the given parameter point on the polygon.

```
bool getCubicSpline( MUInt64 polyId, MPoint vertices[16], MStatus*
ReturnStatus = NULL );
```

Some subdivision faces (usually at level 2 or below) are exactly the same as uniform bi-cubic B-splines. This method will return the 16 points that define such spline.

```
bool polygonIsValid( MUInt64 polyId, MStatus* ReturnStatus = NULL )
const;
```

This method returns if the polygon is valid or not. Valid means that the polygon has been instantiated on the surface. Not all polygons at all levels exist by default. A polygon only exists if it was created at the time the subdiv was first created or if the subdiv was refined.

```
bool polygonHasChildren( MUInt64 polyId, MStatus* ReturnStatus = NULL )
const;
```

This method returns whether or not the given polygon has children.

## MIOStream

You can now import `std::types` required by the devkit.

## MLibrary

You can now initialize API standalone applications in a way that allows you to keep script output.

```
MStatus initialize (bool wantScriptOutput, char* applicationName,
bool viewLicense = false);
```

This method initializes a standalone API application and allows control over if script output will be generated.

## MLightLinks

You can now find out information on ignored lights and objects.

## 14 | API and DevKit

### > MMessage

```
MStatus getIgnoredLights( const MDagPath& path, const MObject& component,  
MDagPathArray& lights );
```

This method queries the light link table to find the lights that ignores a particular object or object component.

```
MStatus getIgnoredObjects( const MDagPath& light, MSelectionList& objects  
);
```

This method queries the light link table to find the objects or object components that are ignored to a particular light.

## MMessage

```
MCallbackId MMessage::currentCallbackId( MStatus* ReturnStatus );
```

You can use this method in a callback for returning the id of the current callback.

```
MStatus MMessage::nodeCallbacks( MObject& node, MIntArray& ids );
```

You can use this method to return the callback ids associated with a node.

## MNodeMessage

```
MCallbackId MNodeMessage::addNodeDirtyCallback( MObject& node, void  
(*func)( MObject& node, void*
```

```
clientData ), void * clientData, MStatus * ReturnStatus );
```

This method lets you add a callback for node dirty messages. Similar to the existing method but now the first parameter of the callback is the node that is dirty.

```
MCallbackId MNodeMessage::addNameChangedCallback( MObject& node, void  
(*func)( MObject & node,
```

```
const MString & prevName, void* clientData ), void * clientData, MStatus  
* ReturnStatus );
```

This method lets you add a callback for name change messages. Similar to the existing method but now the previous name of the node is a parameter to the callback.

```
MCallbackId MNodeMessage::addNodePreRemovalCallback( MObject& node, void
(*func)( MObject& node,
void* clientData ), void * clientData, MStatus * ReturnStatus );
```

This method lets you add a callback that is invoked before the connections of a node about to be deleted are called. Similar to the message generated by:

`addNodeAboutToDeleteCallback()` with the exception that no context is available. This message works correctly when the delete is undone and then redone.

## MPxFieldNode

We now support per particle field attributes on this node.

```
static MObject mInputPPData;
static MObject mOwnerPPData;
```

## MPxManipContainer

You can now create rotation and scale manipulators from this class. In addition, we have added new virtual methods which are called when Maya receives a press, drag or release event.

```
MDagPath addRotateManip(const MString &manipName, const MString
&rotationName);
```

This method creates a rotate manipulator and adds it to the `MPxManipContainer` container.

```
MDagPath addScaleManip(const MString &manipName, const MString
&scaleName);
```

This method creates a scale manipulator and adds it to the `MPxManipContainer` container.

```
virtual MStatusdoPress();
```

This method gets called when the manipulator receives a mouse down event.

```
virtual MStatusdoDrag();
```

## 14 | API and DevKit

### > MPxNode

This method gets called when the manipulator receives a mouse drag event.

```
virtual MStatus doRelease();
```

This method gets called when the manipulator receives a mouse release event.

## MPxNode

We now support `attributeAffects()` style relationships for dynamically-added attributes. Also, you can now get and set internal values using context information.

```
virtual MStatus setDependentsDirty( const MPlug &, MPlugArray & );
```

This method can be overridden in user defined nodes to specify which plugs should be set dirty based upon an input plug.

```
virtual bool getInternalValueInContext( const MPlug&, MDataHandle&, MDGContext& );
```

This method is similar to the existing `getInternalValue()` method but now you have access to the context.

```
virtual bool setInternalValueInContext( const MPlug&, const MDataHandle&, MDGContext& );
```

This method is similar to the existing `setInternalValue()` method but now you have access to the context.

## MRenderView

You can now use a new flag for immediate feedback in the `startRender()` methods.

```
static MStatus startRender( unsigned int width, unsigned int height, bool doNotClearBackground = false, bool immediateFeedback = false );
```

```
static MStatus startRegionRender( unsigned int imageWidth, unsigned int regionRight, unsigned int regionBottom, unsigned int regionTop, bool doNotClearBackground = false, bool immediateFeedback = false );
```

## What's New in Maya 6

Both of the methods now have a new `immediateFeedback` parameter. When set to true, each call to `refresh()` will immediately redraw the Render View. The default setting of false adds a wait of at least two seconds between redraws.

## MRenderUtil

We now support a more general method for extracting the file texture name.

```
static bool exactFileTextureName(const MString& baseName, bool
useFrameExt, const MString& currentFrameExt, MString& exactName, MStatus
*ReturnStatus = NULL);
```

Finds the file texture name on disk based on the input parameters.

## MSelectionMask

Due to internal changes within Maya, the following mask has been removed: `SelectReferences`.

However, we have added the following enum `SelectionType` items:

- `kSelectionHairSystems`
- `kSelectFollicles`

## MString

You can now expand environment variables (all platforms) and tilde (UNIX only).

```
MString expandEnvironmentVariablesAndTilde( MStatus * ReturnStatus = NULL
);
```

Returns a new string constructed by duplicating the current string with all environment variables expanded (and on UNIX, tilde characters ("`~`") are also expanded).

## 14 | API and DevKit

> MTime

### MTime

You can now use new enums for setting animation time units.

k2FPS	//	1/2 sec	k125FPS	//	1/125 sec
k3FPS	//	1/3 sec	k150FPS	//	1/150 sec
k4FPS	//	1/4 sec	k200FPS	//	1/200 sec
k5FPS	//	1/5 sec	k240FPS	//	1/240 sec
k6FPS	//	1/6 sec	k250FPS	//	1/250 sec
k8FPS	//	1/8 sec	k300FPS	//	1/300 sec
k10FPS	//	1/10 sec	k375FPS	//	1/375 sec
k12FPS	//	1/12 sec	k400FPS	//	1/400 sec
k16FPS	//	1/16 sec	k500FPS	//	1/500 sec
k20FPS	//	1/20 sec	k600FPS	//	1/600 sec
k40FPS	//	1/40 sec	k750FPS	//	1/750 sec
k75FPS	//	1/75 sec	k1200FPS	//	1/1200 sec
k80FPS	//	1/80 sec	k1500FPS	//	1/1500 sec
k100FPS	//	1/100 sec	k2000FPS	//	1/2000 sec
k120FPS	//	1/120 sec	k3000FPS	//	1/3000 sec
			k6000FPS	//	1/6000 sec



## MPxHwShaderNode

We now support hardware shaders in high quality interactive and batch hardware rendering. For more information see "Improved hardware plug-in shader support" on page 257.

```
virtual MStatus glBind ( const MDagPath& shapePath );
```

This method will be invoked once per frame and should be overridden to allocate any resources needed for the draw.

```
virtual MStatus glUnbind( const MDagPath& shapePath );
```

This method will be invoked once per frame and should be overridden to deallocate any resources used to draw.

```
virtual MStatus glGeometry( const MDagPath& shapePath,  
int glPrim,unsigned int writeMask, int indexCount, const unsigned  
int*indexArray, int vertexCount, const int * vertexIDs, const float *  
vertexArray, int normalCount, const float ** lArrays, int colorCount,  
const float ** colorArrays,int texCoordCount, const float **  
texCoordArrays);
```

This method is used to perform OpenGL drawing. The arguments contain all the data to successfully call `glDrawElements` or `glDrawRangeElements`.

In addition, several examples have been updated to demonstrate this new functionality.

- `cgfxShaderNode`
- `hwColorPerVertexShader`
- `hwPhongShader`

## 14 | API and DevKit

> Examples of new plug-in functionality

### Examples of new plug-in functionality

#### affectsNode

A new example that demonstrates the use of the `MPxNode::setDependentsDirty()` method. This new method allows for `attributeAffects()` relationships involving dynamic and non-dynamic (i.e. static) Maya attributes.

#### blastCmd

This example plugin has been improved to demonstrate the use of the new off-screen rendering capabilities on the Linux platform.

#### componentScaleManip

A new example that demonstrates the use of the new scale manipulator function set.

#### customAttrManip

A new example that demonstrates how to create user-defined manipulators from a user-defined context.

#### deleteMsgCmd

A new example that demonstrates each of the node deletion callbacks available.

#### dynExprFieldTest

A new example that demonstrates the per particle field attributes support that has been added to the class `MPxFieldNode`.

#### fluidInfoCmd

A new example that demonstrates the usage of the `MFnFluid` class to retrieve fluid information.

## instanceCallbackCmd

A new example that demonstrates listening to instance add and remove messages.

## nodeCreatedCB

A new example that demonstrates how to use API messaging to invoke a callback whenever a node is created.

## particlePathsCmd

A new example that demonstrates the use of the particle id information now available in the `MFnParticleSystem` class.

This example constructs curves from particle paths by tracking particle positions using the new available ids.

## polyMessageCmd

A new example that demonstrates the use of the `MPolyMessage` class to listen to vertex, edge and face component id changes.

## progressWindowCmd

A new example that demonstrates the use of the `MProgressWindow` class.

## renderViewInteractiveRenderCmd

A new example that demonstrates the *immediate feedback* setting that has been added to the `startRender()` methods of the `MRenderView` class.

## rotateManip

A new example that demonstrates the use of a rotation manipulator function set.

## 14 | API and DevKit

> surfaceBumpManip

### surfaceBumpManip

A new example that demonstrates how to use the `PointOnSurface` manipulator function set to create surface bumps.

### undoRedoMsgCmd

A new example that demonstrates the use of the new Undo and Redo events that have been added to the `MEventMessage` class.

### userMsgCmd

A new example that demonstrates the use of the `MUserEventMessage` class. This example allows the creation, removal and posting of user-defined events identified by strings.

## Other significant changes

- The method `MPxNode::addAttributes()` has been modified to fail if child attributes of a compound are added before a parent. Adding the children of a compound before the parent leads to Dependency Graph problems. This method has been modified to prevent this situation. Adding the parent will result in adding the children of a compound, so no additional calls to this method are needed in the compound case.
- The `MFnDagNode` class and its derivatives can crash under certain conditions when the destructor is executed. These classes currently allow the default bitwise copy constructor to be used. Internally, these classes contain pointers to data which can be freed more than once if the default copy constructor is used. If you are running into destructor crashes with the `MFnDagNode` class or its derivatives, define `DISALLOW_COPY_CONSTRUCTOR` before including these classes to provide compile time feedback on where you are using the default copy constructor.

- We have improved the performance of removing messages with the `MMessage` class.
- The stability of the `MObject` class has been improved. Under certain situations an `MObject` could be left with a dangling pointer to a deleted depend node. When the `MObject`'s destructor was then called, a crash would occur. This problem has been solved.
- For Windows, the plug-in and standalone API application project files have been updated for .NET 2003.
- For Windows, the Maya plug-in wizard has been updated for .NET 2003. Currently, the wizard needs to be manually installed. The required files are located in `$MAYA_LOCATION/devkit/pluginwizard` and the associated readme file describes the installation process.
- For IRIX and Linux, the `devkit/plugin-ins/Makefile` now uses a *buildconfig* file that sets the required platform specific flags and options.
- For Mac OS X, standalone API applications are now supported.
- The stand-alone API application build script `$MAYA_LOCATION/bin/mayald` now supports:
  - A `MAYA_LOCATION=...` parameter which lets you hard-code the `MAYA_LOCATION` variable a Makefile
  - An environment variable `MAYA_LDCMD` that lets you specify an alternate linker.

## Compiler requirements

- Maya 6 for Linux requires gcc 3.3.2 for developing API plug-ins and stand alone applications.
- Maya 6 for Mac OS X requires gcc 3.3 for developing API plug-ins and stand alone applications.

## 14 | API and DevKit

> Maya lists new IMF plug-ins

- Maya 6 for Windows requires Microsoft Visual Studio .NET 2003 for building plug-ins and stand alone applications.

### Devkit

#### Maya lists new IMF plug-ins

Now when you write new IMF plug-ins for Maya, IMF (*.imf*) is automatically listed as an Image Format or File Type option in the following locations:

Software and hardware render globals	Image File Output
Image plane node	Input file browser only
File texture node	Input file browser only
Render view	Input and output file browsers
Artisan tools	Input file browser only
Paint Effects panel in canvas mode	Input and output file browsers
Paint Effects panel in scene mode	Save Snapshot browser only

# Index

## Numerics

- 3D Paint Tool
  - improvements 293
  - lipsticking with 224

## A

- Absolute Rotations 133
- accessing Maya browser 52
- Activate Keys 132
- Adaptation Control
  - cpSolver 339
- Add Cache Segment
  - Cloth Cache Editor 348
- Add Selected Characters 114
- adding tracks to characters 105
- Adobe Photoshop 219
- affectsNode
  - example 386
- All mental ray Nodes tab 240
- All Nodes tab 239
- Alphabetical 139
- Angle Tolerance 93
- animation, referenced
  - bake 178
  - export 179
  - import 179
- animation, retargeting 192, 195
  - about 185
  - labeling joints 187
  - Retarget Skeleton Options window 195
  - setting neutral pose 186
  - why use 185
- Annotation node 101
- API
  - significant changes for Maya 6 388
  - What's New in Maya 6 369

# I

- API classes
  - M3dView 370
  - MAnimControl 371
  - MDagMessage 372
  - MDagPath 373
  - MFloatVector 373
  - MFnArrayAttrsData 373
  - MFnCamera 374
  - MFnClip 374
  - MFnDagNode 375
  - MFnDirectionManip 375
  - MFnDoubleIndexedComponent 376
  - MFnFreePointTriadManip 376
  - MFnManip3D 376
  - MFnNurbsCurve 377
  - MFnNurbsSurface 377
  - MFnParticleSystem 377
  - MFnRotateManip 369
  - MFnScaleManip 369
  - MFnSubd 378
  - MIOStream 379
  - MLightLinks 379
  - MMessage 380
  - MNodeMessage 380
  - MObjectHandle 369
  - MObjectSetMessage 369
  - MPolyMessage 370
  - MProgressWindow 370
  - MPxFieldNode 381
  - MPxHwShaderNode 385
  - MPxManipContainer 381
  - MPxNode 382
  - MRenderUtil 383
  - MRenderView 382
  - MSelectionMask 383

- MString 383
- MTime 384
- MTrimBoundaryArray 370
- MUIntArray 370
- MUserEventMessage 370
- MVector 373
- API headers
  - MFileStream 370
- applying
  - per particle field attributes 212
- Artisan 292
  - tools in new architecture 292
- assets
  - sorting in Hypershade 234
- Attach Multiple Output Meshes 97
- audio
  - creating sound clips 108
  - playing sound clips 109
  - Soundtrack 120
- Autoload Selected Characters 114

## B

- Back (Maya Browser) 56
- baking, normal maps 253
- baking, referenced animation 178
- Bend
  - Modify Curves 88
- Bend Amount 88

- Bevel (Edit Polygons menu) 90
- binding to zero-weighted joints 202
- bins
  - working with 234
- blastCmd
  - example 386
- Blend Weights
  - cpProperty 331
- blending animation clips 129
- blends 128
- blends, deleting 130
- blends, editing 130
- blends, graphing weight 130
- browser
  - accessing 52
  - controls 53
  - MEL commands 56
- browser in a panel 51

## C

- cache
  - cloth, advanced editing 343
  - fluids, One File per Frame 296, 298
  - fluids, segmented 299
  - fluids, temporary 295
  - multiple, cloth 344
- Cache Editor
  - cloth 345
- Cache Editor window 348
- Center Current Time 113



- cgfxShader plug-in 257
- changing fluids cache temp directory 302
- channels
  - muting in Dope Sheet and Graph Editor 163
- Character Mapper
  - about 138
  - buttons 143
  - columns 143
  - Edit menu 140
  - fields 142
  - how it works 134
  - Show menu 139
- Character Mapper (Trax Editor) 111
- Character menu
  - Redirect 160
- characters
  - about mapping 134
  - autoload in Trax 114
  - Character Mapper 138
  - Select Character Set Members (Trax Editor) 132
  - Trax Editor 119
- characters, creating clips for 107
- characters, highlighting in Trax 105
- characters, loading into Trax 104, 114
- characters, making redirectable 146
- characters, mapping 134
- Clear All 140
- clip manipulator 127
- clips
  - about blends 128
  - Activate Keys 132
  - Cycle 126
  - editing blends 130
  - Enable Clip 132
  - Frame In 122
  - Frame Out 122
  - groups 119
  - Holds 126
  - interaction controls 124
  - Key into Clips 133
  - Paste Clip 131
  - Scale 122, 125
  - Source In 121
  - Source Out 121
  - Time Warp curve 123
  - Trim 125
  - weight curve 123
- clips, blending 129
- clips, constraint 124
- clips, copying 107
- clips, creating 107
- clips, creating a group 108
- clips, deleting blends 130
- clips, disabling 123
- clips, editing attributes 123
- clips, expression 124
- clips, graphing blends 130
- clips, keying into 133
- clips, multiple
  - manipulator 127
  - moving 109
- clips, pasting 107
- clips, sound 108
  - playing audio 109
  - Soundtrack 120
- clips, source
  - Select Source Clip 132
  - Source In and Source Out 121
- clips, viewing with Outliner 110
- cloth
  - advanced cache editing 343
  - Cache Editor 345
  - multiple caches 344
  - per-face collision depth 336
  - solver diagnostics 342
  - visualizing stress 333
- cloth objects
  - constraints 326
  - improved support for 325
  - painting collision properties 327
  - painting properties 327
  - resolution 326
  - UV sets 327
  - vertex level properties 329
- cloth solver
  - improvements 338
- Cluster Curve 96
- Cluster Curve (Edit Curves menu) 210
- Cluster deformer, creating for CVs 210
- collision depth
  - per face, cloth 336

# I

- color per vertex
  - hardware support for 259
- colors, custom
  - curves 175
- colors, customizing curve 176
- Combine Meshes 75
- command line
  - new render utility 247
- compiler
  - requirements for Maya 6 389
- Component Editor
  - improvements 27
  - improvements for Maya 6 203
- Component Use Object Pivot 97
- componentScaleManip
  - example 386
- configuring Maya browser 54
- constraints
  - clips 124
  - cloth objects 326
- context sensitive menus
  - Trax Editor 130
- contour rendering 268
- Control Bar
  - FCheck 46
- controlling sculpt deformer
  - strength with texture 206
- convert arrays
  - MEL 356

- Convert NURBS to Polygons 97
- Convert NURBS to Subdiv 95
- Convert Polygons to Subdiv 95
- copying clips 107
- cpClothStress node 334
- cpProperty node
  - new attributes 331
- cpSolver node
  - new attributes 339
- Create Blend (Trax icon) 114
- Create Clip (Trax icon) 114
- Create Lattice Options window
  - Falloff Distance 205
  - Outside Points Transform 204
- Create Layer 45
- Create Meshes Single Sided 93
- creating a group of clips 108
- creating clips 107
- creating fluid caches 295
- creating references
  - compared with importing preserved references 36
- creating sound clips 108
- Curl
  - Modify Curves 87
- Curl Amount 87
- Curl Frequency 88

- curves
  - about custom colors 175
  - customizing color 176
  - deforming with lattice 169, 171
  - muting in Dope Sheet and Graph Editor 163
- custom animation curve
  - colors about 175
- Custom Equalizer Maps
  - fur 317
- customAttrManip
  - example 386
- customizing curve color 176
  - example (MEL) 184
- Cut Along 75
- Cut Off
  - cpClothStress 335
- CV
  - clusters 210
- Cycle 126

# D

- dds image type 365
- default file loading 40
- Default scene 40
- Default Trim Curves 366
- Deformable 83
- deformer, Jiggle
  - restrict jiggle direction 208

- deformer, lattice
  - affecting points outside lattice 204
- deforming curves with lattice 171
- deforming particles 211
- Delete Unused Layers 46
- deleteMsgCmd
  - example 386
- deleting blends 130
- deleting non-skin history 202
  - why use 201
- Depth Map Enable
  - collision object 337
- Depth Map Weight
  - collision object 337
- Devkit
  - What's New in Maya 6 369
- diagnostics
  - mental ray for Maya 289
- Direction Bias 208
- directory, temp
  - making space for fluids cache 302
  - not enough space for fluids cache 302
- Disable Clip 123
- Disable Cutoff
  - cpClothStress 335
- disabling clips 123
- disabling script output on particle events 217

- disk
  - not enough space for fluids cache 304
- Display Channel Names 140
- Display Node Names 140
- Draw Type
  - cpClothStress 335
- Duplicate (Trax Editor) 111
- DWG translator
  - improvements 365
- dynExprFieldTest
  - example 386

## E

- Edit menu (Character Mapper) 140
- Edit menu (Trax Editor) 111
- editing clip attributes 123
- editing, animation blends 130
- Enable Advanced 207
- Enable Clip 132
- Enable Default Scene 40
- environment variable
  - MAYA\_FUR\_LIGHT\_CLAMPING 322
  - MAYA\_FUR\_OLD\_BEHAVIOR 322
- equalizer map
  - fur, improvements 317

- examples
  - affectsNode 386
  - blastCmd 386
  - componentScaleManip 386
  - 6
  - customAttrManip 386
  - customizing curve color 184
  - deleteMsgCmd 386
  - dynExprFieldTest 386
  - instanceCallbackCmd 387
  - One File per Frame fluids cache 298
  - particlePathsCmd 387
  - polyMessageCmd 387
  - progressWindowCmd 387
  - 7
  - redirecting animation 148
  - renderViewInteractiveRenderCmd 387
  - rotateManip 387
  - segmented fluids cache (MEL) 301
  - surfaceBumpManip 388
  - undoRedoMsgCmd 388
  - userMsgCmd 388
- export
  - referenced animation 179
- exporting references 37
- expression
  - applied after dynamics 215
  - applied before dynamics 215
- expressions
  - clips 124

# I

## F

- Falloff Around Selection 61
- Falloff Based On 62
- Falloff Curve 60
- Falloff Distance 205
- Falloff Radius 60
- FCheck
  - Control Bar 46
  - Full Screen 47
  - improvements 46
  - sound 47
- field attributes
  - per particle 212
- File menu (Trax Editor) 111
- files, loading selected 28
- filtering
  - nodes in Hypershade 237
- Final Gather
  - photon visualization 286
- fluids cache
  - creating temporary 295
  - making space for 302
  - One Frame per File 298
  - re-establish link with 304
  - Replace Cache Frame 306
  - segmenting 299
  - troubleshooting 301, 303
  - turning off local creation 296
- Force All 202
- Forward (Maya browser) 57
- Frame All (Trax icon) 115
- Frame In 122
- Frame Out 122

- Frame Playback Range 113
- Frame Playback Range (Trax icon) 115
- frames
  - playblast 178
- freeze transformation
  - improvements 41
- Freeze Transformations 98
- Fur
  - changes 309
- fur
  - equalizer map
    - improvements 317
  - painting
    - improvements 319
  - rendering in mental ray 309
  - Subdivision Surfaces 319
- Fur Feedback
  - hide fur 320
  - improvements 320
  - Render Stats 314
  - show fur 320
  - switch between 321

## G

- Get Clips (Trax icon) 115
- ghosting
  - parts of objects 177
- Go to Neutral Pose (Skeleton menu) 193
- goalU 212
- goalV 212
- Graph Anim Curves (Trax icon) 115

- Graph Editor
  - Lattice Deform Keys Tool 169
  - Move Keys Tool 167
- Graph Weight Curves (Trax icon) 115
- graphing blend curves 130
- Group (Trax Editor) 113
- Group (Trax icon) 115
- grouping clips 108
- groups
  - clips 119
  - highlighting in Trax 105

## H

- hardware plug-in shaders 257
- Hardware rendering
  - color per vertex support 259
  - command line rendering 247
  - performance
    - improvements 257
- Heads Up Display 96
- Hide All Labels 194
- Hide Cloth Stress 333
- Hide Zero Columns 27
- Hierarchical 139
- hierarchy
  - tracks in the Trax Editor 118
- High Stress Color
  - cpClothStress 334

- highlighting characters in
  - Trax 105
- hinge constraints
  - parenting 218
- history, deleting non-skin 202
- Holds 126
- Home (Maya browser) 57
- hwColorPerVertexShader
  - plug-in 257
- Hypergraph
  - node colors 43
- Hypershade
  - custom tabs 239
  - new sorting bins 234
  - performance
    - improvements 233
  - shape and transform
    - nodes in 240
  - tab filtering in 237

## I

- IBL. See Image-Based Lighting
- IGES import/export options
  - improvements 365
- illumination
  - sky-like 278
- image file support
  - dds 365
  - png 365
- image planes
  - using sequences with 245

- image sequences
  - rendering
    - improvements 245
- Image-Based Lighting 278
- IMF
  - new functionality for
    - Maya 6 390
- IMF plug-ins 253
- importing
  - referenced animation 179
  - STL 367
- importing preserved
  - references
    - compared with creating
      - references 36
- importing shading
  - networks 252
- importing sound (FCheck) 47
- Instance Leaf Nodes 41
- instanceCallbackCmd
  - example 387
- instancing
  - improvements 41
- Interactive Playback
  - improvements 218
- Interactive Shading Mode
  - setting options for 232
- Interpolation Type
  - Cloth Cache Editor 349
- IPR rendering
  - with mental ray for
    - Maya 265
- Is Soft
  - mesh constraint 338

## J

- Jiggle deformer
  - restrict jiggle
    - direction 208
- Joint Labelling menu
  - (Skeleton menu) 193
- joint labels
  - Hide All Labels 194
  - Joint Labelling 193
  - Label Based On Joint Names 194
  - Rename Joints Labels 194
  - Show All Labels 194
  - Toggle Selected Labels 194
  - visibility 191
- joint labels, applying 187
- joint labels, removing 191
- joints, labeling 187
- joints, retargeting
  - animation 185, 192
- joints, setting the neutral pose 186

## K

- Key into clip (Trax icon) 116
- keying into clips 132, 133
- keys
  - deforming with lattice 169
  - manipulating groups 167

# I

## L

Label Based On Joint  
Names 194

labeling joints for  
retargeting 187

labels, joint  
Hide All Labels 194  
Joint Labelling 193  
Label Based On Joint  
Names 194  
Rename Joints From  
Labels 194  
Show All Labels 194  
Toggle Selected  
Labels 194

labels, removing from  
joints 191

labels, toggling visibility 191

Lattice Deform Keys Tool 169

Lattice deformer  
deforming points  
outside 204

Lattice Settings (Lattice  
Deform Keys tool) 170

lattices  
deforming curves 169, 171

Layer Editor  
improvements 45

Level Mapping 366

light linking  
improvements 288

lightmaps  
performance  
improvements 288

lipsticking 224

List menu (Trax Editor) 114  
Load No References 31  
Load Related References 32  
Load Selected Characters 114  
loading characters into  
Trax 104, 114  
loading default file 40  
loading mental ray  
shaders 264  
loading references 30, 35  
MEL 358  
loading selected files 28  
loading textures,  
disabling 245  
Locator 35  
locators  
reference 33  
Lock 116  
Lock Length 84  
locking tracks 116  
Low Stress Color  
cpClothStress 334  
Lower Body Scale 198  
Lower Body Solution 196

## M

M3dView  
changes in Maya 6 370  
Maintain Offset 196  
makeIdentity 98  
making space in directory for  
fluids cache 302

MAnimControl  
changes in Maya 6 371  
manipulating  
references 33  
manipulating curves with  
lattice manipulator 169  
Map based on hierarchy 141  
Map based on order 142  
mapping characters 134  
workflow 137  
mapVizShape node 287  
Mask Unselected 60  
master bin 234  
Match Knots 98  
Max Curvature  
Scale Curvature 89  
Maya browser 51  
accessing 52  
configuring 54  
controls 53  
MEL commands 56  
Maya hardware  
rendering 257  
Maya software rendering 248  
maya.rayrc 264  
MAYA\_FUR\_LIGHT\_CLAM  
PING 322  
MAYA\_FUR\_OLD\_BEHAVI  
OR 322  
MAYA\_MRFM\_SHOW\_CUS  
TOM\_SHADERS 264  
MAYA\_SCRIPT\_PATH  
changes 351  
MDagMessage  
changes in Maya 6 372

MDagPath  
 changes in Maya 6 373

MEL  
 convert arrays 356  
 new and improved  
 commands 351

MEL commands in Maya  
 browser 56

mental ray for Maya  
 fur, rendering 309

mental ray for Maya  
 rendering 264  
 command line  
 rendering 247  
 connecting shaders 265  
 diagnostics 289  
 IPR rendering 265

Menu bar  
 Trax Editor 110

menus  
 context sensitive (Trax  
 Editor) 130

Merge Tolerance 97

Merge Vertex Tolerance  
 (Mirror Cut option) 75

Merge Vertex Tolerance  
 (Smooth Proxy  
 option) 78

Merge Vertices 97

Merge vertices with  
 tolerance 367

merging vertices 367

Mesh Draw Offset  
 cpClothStress 336

MFloatVector  
 change in Maya 6 373

MFnArrayAttrsData  
 changes in Maya 6 373

MFnCamera  
 changes in Maya 6 374

MFnClip  
 changes in Maya 6 374

MFnDagNode  
 change in Maya 6 375

MFnDirectionManip  
 changes in Maya 6 375

MFnDoubleIndexedComponent  
 changes in Maya 6 376

MFnFreePointTriadManip  
 changes in Maya 6 376

MFnManip3D  
 changes in Maya 6.0 376

MFnNurbsCurve  
 changes in Maya 6 377

MFnNurbsSurface  
 changes in Maya 6 377

MFnParticleSystem  
 changes in Maya 6 377

MFnRotateManip 369

MFnScaleManip 369

MFnSubd  
 changes in Maya 6 378

MFnStream 370

MI\_CUSTOM\_SHADER\_PATH  
 H 264

MIOStream  
 changes in Maya 6 379

Mirror Behavior 76

Mirror Cut, Polygons 73

Mirror Direction 78

MLightLinks  
 changes in Maya 6 379

MMessage  
 changes in Maya 6 380

MNodeMessage  
 changes in Maya 6 380

MObjectHandle 369

MObjectSetMessage 369

Modify Curves 84

monitorScript  
 cpSolver 340  
 parameters 340

motion redirection  
 how to use 146  
 why use 144  
 workflow 145

Move Falloff 169

Move Keys Tool 167

moving groups of  
 keyframes 167

moving multiple clips 109

MPolyMessage 370

MProgressWindow 370

MPxFieldNode  
 changes in Maya 6 381

MPxHwShaderNode  
 changes in Maya 6 385

MPxManipContainer  
 changes in Maya 6 381

MPxNode  
 changes in Maya 6 382

MRenderUtil  
 changes in Maya 6 383

MRenderView  
 changes in Maya 6 382

# I

- MSelectionMask
  - changes in Maya 6 383
- MString
  - changes in Maya 6 383
- MTime
  - changes in Maya 6 384
- MTrimBoundaryArray 370
- MUIntArray 370
- MUserEventMessage 370
- Mute 117
- mute curve 163
  - why use 163
- muting channels in Dope Sheet and Graph Editor 163
- muting tracks 117
- MVector
  - changes in Maya 6 373

# N

- Neutral Pose 196
- neutral pose
  - Go to Neutral Pose 193
  - Set Neutral Pose 193
- Neutral Pose Frame 196
- neutral pose, setting 186
- node colors 43
- Node Display Override
  - Color 44
- nodes
  - sorting in Hypershade 234
- Non Uniform 207

- nonlinear animation
  - blends 128
  - Trax Editor in Maya 6 103
- non-photorealistic rendering 268
- normal map baking 253
- Normals
  - Freeze Transformations option 99

# O

- Object space, normal map baking 254
- Object Type 177
- off-screen playblast 178
- Offset Distance
  - Polygon Bevel attribute 92
- Offset Space 91
- Offset Type 91
- One File per Frame
  - about 296
  - creating segmented caches 298
  - Example 298
  - why use 296
- Only for non-rigid deformations 100
- Open (Maya browser) 56
- Open Help In Main Maya Window 55
- Open Help Using External Browser 55

- OpenFlight
  - Mac OS X support 367
- Operation
  - Cloth Cache Editor 348
- Optimize Scene Size
  - customizing, MEL 360
  - improvements 37
  - reporting 38
- Outliner
  - viewing all animation clips 110
- Outside Points Transform 204
- overlapping objects
  - selecting 44

# P

- paint
  - polygons, on 291
- Paint Collision Properties Tool 293
- Paint Effects 291
  - polygons 291
  - render progress indicator 291
  - UV linking 291
- Paint Fur Attributes Tool
  - improvements 319
- Paint Hair Tool 292
- Paint Resolution 207
- Paint Scripts Tool
  - improvements 293, 360
- Paint Sculpt Map 208
  - 3D Paint Tool improvements 293



- painting
    - fur, improvements 319
    - in Photoshop 224
  - painting cloth object
    - properties 327
  - painting collision object
    - properties 327
  - panel
    - Web browser 51
  - parenting hinge
    - constraints 218
  - particle events
    - disabling script output 217
  - particle motion blur
    - rendering 288
  - particlePathsCmd
    - example 387
  - particles
    - deforming 211
    - random number streams 216
  - Paste Clip 131
  - pasting clips 107
  - per-face collision depth 336
  - performance improvements
    - Hardware rendering 257, 262
    - Hypershade 233
    - lightmaps 288
  - per-particle field
    - attributes 212
    - applying 212
  - per-particle goalU/goalV
    - attributes 212
  - photons
    - visualization 286
  - Photoshop. See Adobe Photoshop. 219
  - Pixel Snap 94
  - playback range
    - setting to range of clips in Trax 110
  - Playblast
    - command 178
  - playing sound clips 109
  - plug-ins
    - IMF 390
  - png image type 365
  - Poly Mirror Cut 73
  - polyBevel node 93
  - polygon
    - Paint Effects 291
    - painting on 291
  - Polygon Proxy Mode 90
  - polygon surface
    - textured surface emission 216
  - Polygons menu
    - Unmirror Smooth Proxy 82
  - polymesh goal objects
    - per-particle attributes 212
  - polyMessageCmd
    - example 387
  - polyNormalPerVertex 100
  - Pop-up Menu Selection 44
  - poses, neutral
    - Go to Neutral Pose 193
    - Set Neutral Pose 193
  - Preload Reference Editor 30
  - pre-loading references 30
  - Preserve History 60
  - Preserve Length 86
  - Preserve Reference 36
  - preserving references 36
  - progress indicator
    - Paint Effects render 291
  - progressWindowCmd
    - example 387
  - Proxy Mesh Renderable 81
  - PSD files
    - converting to network 222
    - creating in Maya 222
    - updating 225
    - use existing 221
- ## R
- random number streams
    - MEL 357
  - random number streams for particles 216
  - Read Equalizer Maps
    - fur 318
  - Rebuild Curve 98
  - Rebuild Method 98
  - Rebuild Surfaces 98
  - Redirect (Character menu) 160
  - redirecting animation 146
    - example 148
    - workflow 145
  - Redirection Type 161

# I

- redirection, motion
  - about 144
  - how to use 146
- Reference Editor
  - improvements 31
- reference locators 33
- referenced animation
  - baking 178
- references
  - exporting 37
  - loading 30, 35
  - loading, MEL 358
  - manipulating 33
  - pre-loading 30
  - preserving 36
  - reloading 36
  - unloading 35
- reflections
  - rendering blurry 276
- refractions
  - rendering blurry 276
- Refresh 141
- Reload 56
- Reload (Maya browser) 56
- reloading references 36
- remapColor utility 251
- remapHsv utility 251
- remapValue utility 250
- removing cloth properties
  - cloth objects 332
- removing labels from
  - joints 191
- Rename Joints From Labels 194
- render
  - fur in mental ray 309
  - Paint Effects progress indicator 291
- render globals
  - hardware renderer 262
- render nodes
  - bin organization 234
- Render Stats
  - FurFeedbackShape node 314
- render utility
  - new 247
- rendering 219
  - blurry refractions 276
  - contours 268
  - Maya Fluids 267
  - Maya Fur 268
- renderViewInteractiveRender Cmd
  - example 387
- Replace Cache Frame 306
- restricting jiggle direction 208
- Retarget Skeleton Options
  - window 195
  - Lower Body 196
  - Neutral Pose 196
  - Time 201
  - Upper Body 198
- retargeting animation 192
  - about 185
  - labeling joints 187
  - Retarget Skeleton Options window 195
  - setting the neutral pose 186
  - workflow 185
- rigid bind 202
- Rigid Bind Options window
  - Force All 202
- RN suffix 34
- Rotate Mode 83
- rotateManip
  - example 387
- rotations
  - absolute 133
- runtime expressions
  - dynamics 215

# S

- Scale 122, 125
- Scale Curvature 88
- Scale Factor 366, 367
  - Scale Curvature 88
- Script Editor
  - improvements 42
- Sculpt deformer
  - using texture map 205
- Sculpt Deformer Options window
  - Advanced Sculpt Deformer Attributes 207
- Sculpt Polygons Tool 98

- Sculpt Surfaces Tool 98
  - improvements 293
- See also PSD files.
- segmenting fluids cache 298, 299
  - example 301
- Select Character Set
  - Members 132
- Select Curve CVs 96
- Select First CV on Curve 96
- Select Last CV on Curve 96
- Select Source Clip 132
- selecting
  - overlapping objects 44
- selecting character set
  - members 132
- selective file loading 28
- selective load settings 28
- Selective Preload 30, 31
- Set List
  - cpProperty 331
- Set Neutral Pose (Skeleton menu) 193
- setting neutral pose for
  - skeletons 186
- setting Time Slider's playback range to the range of the clips in Trax 110
- shader glow
  - rendering 288
- Shader manager 264
- shaders
  - connecting 265
  - hardware plug-in 257
- shading networks
  - import improvements 252
  - removing redundant 252
  - testing portions of 242
- shading, interactive 228
- shape nodes
  - hiding 240
- Share Transform Node 80
- Show All Columns 28
- Show All Labels 194
- Show Cloth Stress 333
- Show menu (Character Mapper) 139
- Show Selected Columns 28
- Show Selected Objects 28
- skeletons, labeling 187
- skeletons, retargeting
  - animation 185, 192
- skeletons, setting the neutral pose 186
- skin, deleting history 202
- skin, soft bind 203
- sky-like illumination 278
- Smooth
  - Modify Curves 87
- Smooth Factor 87
- Smooth Proxy (Polygons menu) 75
- Smooth, Polygons 89
- soft bind 203
- Soft Modification Tool 59, 203
- Software rendering
  - command line
    - rendering 247
    - new color utility nodes 248
- Solo 117
- soloing tracks 117
- solver
  - cloth, diagnostics 342
  - cloth, improvements 338
- Sort Alphabetically (Component Editor) 27
- Sort Layers Alphabetically 46
- Sort Layers
  - Chronologically 46
- sound
  - importing to FCheck 47
- sound clips 108
- Soundtrack 120
- Source In 121
- Source Out 121
- Split Polygon Tool 95
- Stitch
  - cloth constraint 337
- STL import 367
- Stop Loading (Maya browser) 56
- Straighten 85
- Straightness 86
- stress
  - cloth 333
- Stress Scale Factor
  - cpClothStress 336
- strokes
  - isolate for render 291

# I

- StudioImport
  - Mac OS X support 368
- subcharacters (Trax Editor) 119
  - highlighting
  - summaries 105
- Subdivision Surfaces
  - fur 319
- summaries
  - characters 120
  - groups 120
  - subcharacters 120
- Suppress Command Results 42
- Suppress Error Messages 42
- Suppress Info Messages 42
- Suppress Warning Messages 42
- surfaceBumpManip
  - example 388

# T

- tabs
  - in Hypershade 239
- Tangent space, normal map baking 254
- Target Cache
  - Cloth Cache Editor 348
- Target Range
  - Cloth Cache Editor 348
- testing
  - textures 242
- Texture 207
- texture map
  - Sculpt deformer 205
- Texture Multiplier 207
- textures
  - disabling loading 245
  - mental ray 289
  - testing 242
- Time Range 201
- Time Warp
  - display on clips 123
- time working units
  - additions for Maya 6 177
- Toggle Selected Labels 194
- tooggling joint label
  - visibility 191
- tools
  - Artisan new architecture 292
  - Lattice Deform Keys 169
  - Move Keys 167
- Track control area 116
- Track view area 118
- tracks
  - hierarchy in Trax 118
  - Track control area 116
  - Track view area 118
- tracks, adding to characters 105
- tracks, locking 116
- tracks, muting 117
- tracks, soloing 117
- transform nodes
  - hiding 240

- Trax Editor
  - adding tracks 105
  - changes for Maya 6 103
  - context sensitive menus 130
  - creating clips 107
  - grouping clips 108
  - hierarchy of tracks 118
  - highlighting
    - summaries 105
  - loading characters 104
  - Menu bar items 110
  - Soundtrack 120
  - summaries 120
  - Track control area 116
  - Track view area 118
- Trim 125
- Trim After 111
- Trim Before 111
- Trim clip after current time 116
- Trip clip before current time 116
- troubleshooting
  - fluids cache 301, 303
- turning off local fluids cache creation 296
- Twist attribute
  - Bend tool 88

# U

- undoRedoMsgCmd
  - example 388
- Ungroup (Trax Editor) 113, 115

- unlabeling joints 191
- Unload Related References 32
- unloading references 35
- unloading shaders
  - mental ray for Maya 264
- Unlock Length 85
- Unmap 140
- Unmap All 140
- Unmirror Direction 82
- Unmirror Smooth Proxy
  - (Polygons menu) 82
- Update Maps
  - fur 320
- Upper Body Scale 200
- Upper Body Solution 198
- userMsgCmd
  - example 388
- UV linking
  - Paint Effects 291

- UV sets
  - cloth 327
- UV Texture Editor 94

## V

- variable
  - MAYA\_FUR\_LIGHT\_CLAMPING 322
  - MAYA\_FUR\_OLD\_BEHAVIOR 322
- Vector rendering
  - command line rendering 247
- vertex level cloth
  - properties 329
- Vertex Normal Edit Tool 82, 203
- vertices, merging 367
- View Image 40
- View menu (Trax Editor) 113

- View Sequence 40
- viewing animation clips from the Outliner 110
- visibility, joint labels 191
- Visualize Texture 208

## W

- Web browser 51
  - accessing 52
  - controls 53
  - in a panel, MEL 363
  - MEL commands 56
- weight
  - curve display on clips 123
- What's/wheelmouse 27
- workflow
  - mapping characters 137
  - redirecting animation 145
  - retargeting animation 185

I