

Basics

Version 6

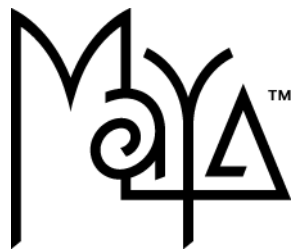

© Copyright 2004 Alias Systems, a division of Silicon Graphics Limited ("Alias"). All images © Copyright Alias unless otherwise noted. All rights reserved.

Alias is a registered trademark and the swirl logo, the Maya logo, Conductors, Trax, IPR, Maya Shockwave 3D Exporter and MEL are trademarks of Alias in the United States and/or other countries worldwide. Maya is a registered trademark of Silicon Graphics, Inc. in the United States and/or other countries worldwide, used exclusively by Alias. SGI, IRIX, Open GL and Silicon Graphics are registered trademarks of Silicon Graphics, Inc. in the United States and/or other countries worldwide. mental ray and mental images are registered trademarks of mental images GmbH & CO. KG. in the United States and/or other countries. Lingo, Macromedia, Director, Shockwave and Macromedia Flash are trademarks or registered trademarks of Macromedia, Inc. Wacom is a trademark of Wacom Co., Ltd. NVidia is a registered trademark and Gforce is a trademark of NVidia Corporation. Linux is a registered trademark of Linus Torvalds. Intel and Pentium are registered trademarks of Intel Corporation. Red Hat is a registered trademark of Red Hat, Inc. ActiveX, Microsoft and Windows are either registered trademarks or trademarks of Microsoft Corporation in the United States and/or other countries. Mac, Macintosh and QuickTime are trademarks of Apple Computer, Inc., registered in the United States and other countries. Adobe, Adobe Illustrator, Photoshop and Acrobat are either registered trademarks or trademarks of Adobe Systems Incorporated. UNIX is a registered trademark, licensed exclusively through X/Open Company, Ltd. AutoCAD, Discreet Logic, Inferno and Flame are either registered trademarks or trademarks of Autodesk, Inc. in the USA and/or other countries. OpenFlight is a registered trademark of MultiGen Inc. Java is a registered trademark of Sun Microsystems, Inc. RenderMan is a registered trademark of Pixar Corporation. Softimage is either a registered trademark or trademark of Avid Technology, Inc. in the United States and/or other countries. All other trademarks, trade names, service marks, or product names mentioned herein are property of their respective owners.

This document contains proprietary and confidential information of Alias, and is protected by Federal copyright law and international intellectual property conventions and treaties. The contents of this document may not be disclosed to third parties, translated, copied, or duplicated in any form, in whole or in part, or by any means, electronic, mechanical, photocopying, recording or otherwise, without the express prior written consent of Alias. The information contained in this document is subject to change without notice. Neither Alias, nor its affiliates, nor their respective directors, officers, employees, or agents are responsible for any damages of any kind arising out of or resulting from the use of this material, including, without limitation, any lost profits or any other direct, indirect, special, incidental, or consequential damages or for technical or editorial omissions made herein.



Table of contents

1	Interface overview	15
About	Working in Maya	15
	3D	16
	3D coordinates	16
	Maya's Interface	17
	Objects and components	17
	Selection, tools, and actions	17
	Main window	18
	Menus and menu sets	20
	Marking menus	21
	Shelves	22
	Web browser in a panel	22
How do I?	Get help	24
	Print the Maya Help	24
	Work with menu items, tools, and options	25
	Choose tools and actions	25
	Set the options for a tool or menu item	26
	Choose actions from marking menus	26
	Choose actions from the hotbox	27
	Choose actions on a shelf	27
	Load the default shelves	28
	Start Maya from the command line	29
	Use the Maya browser	31
	Configure the Maya browser	32
Reference	Tools	34
	Status line (toolbar)	34
	Command line	37
	Toolbox	37
	Select tool	37
	Lasso tool	37
	Show Manipulator tool	38

Table of Contents

	Windows and editors	38
	Maya Browser (Web browser in a panel)	38
	Maya Help	40
	Maya Help search engine	40
	Menus	41
	Edit.	41
	Edit > Undo, Redo, Repeat	41
	Modify	41
	Modify > Make Live	41
	Display	41
	Display > UI Elements	41
	Window	42
	Window > Settings/Preferences > Tool Settings	42
	Tips	42
	Maya Help search tips	42
2	Selecting	45
How do I?	Select	45
	Select objects or components	45
	Select a node	48
	Select only certain types of objects or components (selection masks)	48
	Save and reuse a selection	49
	Select objects based on hierarchy	50
	Select components by painting	50
	Change one type of selection to another	51
	Grow, shrink, or change the selected region of CVs or polygon components	51
Reference	Menus	52
	Edit.	52
	Edit > Select All, Select Hierarchy, Invert Selection	52
	Edit > Select All by Type	53
	Edit > Quick Select Sets	53

Table of Contents

	Edit > Paint Selection Tool	53
	Create	55
	Create > Sets > Quick Select Set	55
3	Viewing the scene	57
How do I?	View the scene and change the display	57
	Move and rotate the camera	57
	Tumble, track, dolly, or tilt the view	57
	Use the mouse to control camera azimuth, elevation, yaw or pitch ..	59
	Center the view on selected or all objects	59
	Return to previous views	60
	Change and resize panels	60
	Change the panel layout	60
	Create a window from the contents of a panel (tear off)	62
	Control what camera is shown in a view	62
	Show, hide, or change the grid	63
	Show information over top of a view (heads-up display)	63
	Change the display of objects	63
	Change the look and smoothness of the selected objects	63
	Show or hide objects	64
	Show or hide components	65
	Show or hide object-specific UI	66
	Show an isolated subset of objects or components in a panel	67
	Change an object's wireframe color	68
Reference	Tools	69
	Quick layout buttons	69
	Menus	69
	Display	69
	Display > Grid	69
	Display > Heads Up Display	71
	Display > Hide, Show	73
	Display > Wireframe Color	75
	Display > Object Display	75

Table of Contents

Display > Component Display	75
Display > Camera/Light Manipulator	77
Window	78
Window > Frame All in All Views, Frame Selection in All Views	78
Panel menus	78
View > Camera Settings	78
View > Camera Tools > Tumble Tool	80
View > Camera Tools > Track Tool	81
View > Camera Tools > Dolly Tool	82
View > Camera Tools > Zoom Tool	83
View > Camera Tools > Roll Tool	83
View > Camera Tools > Azimuth Elevation Tool	83
View > Camera Tools > Yaw Pitch Tool	84
View > Camera Tools > Fly Tool	85
Show menu	85
Show > Isolate Select	85
Show > Grid	86
Shading menu	86
Lighting menu	89
Panels menu	90
Windows and editors	93
Panel editor	93
Nodes	97
Camera node	97
4 Transforming objects	103
About 3D	103
Transformations	103
The pivot point	103
World space, object space, and local space	104

Table of Contents

	Maya's interface	105
	Construction history	105
	Construction planes	106
	Copies vs. instances	106
How do I?	Transform objects and components	107
	Use manipulators	107
	Lock a manipulator to the current selection	110
	Move, rotate, or scale objects	110
	Move, rotate or scale components proportionally.	111
	Change the pivot point.	113
	Flip objects	114
	Transform along different axes	114
	Set transformation values to zero	115
	Align and snap	116
	Snap to the grid, a curve, points, or a view plane	116
	Snap all creation tools to a surface or construction plane	117
	Align objects	117
	Snap one object to another	119
	Change history	121
	Undo, Redo, and Repeat	121
	Edit completed commands (construction history).	121
	Show a custom manipulator for the selected node.	122
	Create and edit models	122
	Create geometric primitives.	122
	Create text	123
	Edit objects	123
	Delete	123
	Duplicate	124
	Edit component numeric values directly	125
Reference	Tools	127
	Toolbox	127
	Move tool.	127
	Rotate tool	129

Table of Contents

Scale tool	130
Menus	131
Edit.	131
Edit > Delete	131
Edit > Delete by Type > History	132
Edit > Delete by Type > Channels, Static Channels, Non-particle Expressions	132
Edit > Delete All by Type	132
Edit > Duplicate	133
Edit > Duplicate with Transform	135
Modify	135
Modify > Transformation Tools > Move Tool, Rotate Tool, Scale Tool, Show Manipulator Tool	135
Modify > Transformation Tools > Move Normal Tool	135
Modify > Transformation Tools > Move/Rotate/Scale Tool	136
Modify > Transformation Tools > Default Object Manipulator	136
Modify > Transformation Tools > Proportional Modification Tool	136
Modify > Reset Transformations, Freeze Transformations	139
Modify > Snap Align Objects > Point to Point, 2 Points to 2 Points, 3 Points to 3 Points	140
Modify > Snap Align Objects > Align Objects	141
Modify > Snap Align Objects > Align Tool	142
Modify > Snap Align Objects > Snap Together Tool	143
Modify > Center Pivot	144
Create.	144
Create > Text	144
Create > Construction Plane	144
Windows and editors	145
Component editor.	145
5 Nodes and attributes	149
About Nodes and attributes	149
Nodes and attributes	149
Two views of the scene: hierarchy and dependency.	152

Table of Contents

	Scene hierarchy	152
	Dependency graph	153
	The Outliner.	154
	The Hypergraph	155
	Node types	157
How do I?	Work with nodes and attributes	159
	View and edit attributes	159
	Change attribute values in the Attribute Editor or Channel Box . . .	159
	Show or hide the manipulator for an attribute in the Channel Box .	161
	View and edit multiple attributes on multiple nodes.	162
	Save and reuse attribute presets.	164
	Lock the value of an attribute	166
	Create, edit, or delete custom attributes.	166
	Open multiple Attribute Editors.	167
	Control the display of attributes in the Channel Box.	167
	View and change the hierarchy of nodes.	168
	View and edit the hierarchy of nodes	168
	Change the visual layout of nodes in the Hypergraph	170
	Change the order of nodes	171
	View and change input and output history relationships between nodes	171
	Show inputs and outputs (dependency graph)	171
	Connect input and output attributes	172
	Connect attributes with an expression	173
	Break connections between attributes	174
	Set a node's update state.	174
	Change the display of nodes and attributes	175
	Show or hide nodes	175
	Control which objects or attribute types appear in an editor	176
	Save and reuse object or attribute visibility filters in editors	177
Reference	Menus	178
	Edit.	178
	Edit > Select Hierarchy	178

Table of Contents

	Edit > Parent	178
	Edit > Unparent	179
	Modify	179
	Modify > Evaluate Nodes	179
	Modify > Prefix Hierarchy Names	179
	Modify > Add Attribute	180
	Modify > Edit Attribute	184
	Modify > Delete Attribute	185
	Windows and Editors	185
	Outliner	185
	Attribute Editor	189
	Attribute Spread Sheet	195
	Channel Box	196
	Hypergraph	202
	Hypergraph	202
	Hypergraph tips	210
	Hypergraph limitations	211
6	Files and organization	213
About	Files and organization	213
	Organizing objects	213
	Sets and partitions	213
	File referencing	214
	Supported file formats	215
How do I?	Work with files	219
	Create, open, or save a scene file	219
	Import or reference data in an external file	220
	Export objects to a new file	222
	View images or animations	222
	Optimize scene size	222
	Organize files into projects	223
	Recover data after a crash	224

Table of Contents

	Organize and annotate	224
	Organize objects	224
	Change the name of one or more objects	224
	Make an object unselectable (template)	225
	Organize objects on display layers	226
	Edit all objects on a layer at once	227
	Group objects together	227
	Create and edit sets	228
	Keep a collection of sets from having overlapping membership. . .	228
	Annotate and measure.	230
	Annotate or document objects	230
	Measure the distance between two points.	230
	Show parameter or arc-length values on a curve or surface	231
	Menus	231
	File	231
	File > New Scene	231
	File > Open Scene	232
	File > Save Scene	234
	File > Save Scene As	235
	File > Optimize Scene Size	237
	File > Import	237
	File > Export All, Export Selection	242
	File > Create Reference	245
	File > Reference Editor	247
	File > Project > New	247
	File > Project > Edit Current	248
	File > Project > Set	248
	Edit.	248
	Edit > Group	248
	Edit > Ungroup	249
	Edit > Level of Detail	250
	Display	252
	Display > Object Display > Template, Untemplate	252

Reference

Table of Contents

Create	252
Create > Measure Tools > Distance Tool, Parameter Tool, Arc Length Tool	252
Create > Locator	252
Create > Annotation	252
Create > Sets > Set, Partition	253
Create > Empty Group	253
Windows and editors	253
Reference Editor	253
Preload Reference Editor	255
Layer Editor	256
Relationship Editor	259
Color editor	262
Visor	265
Nodes	268
General attributes	268
General attributes	268
Transform attributes	268
Display	269
Node behavior	270
Level of Detail group node	271
7 Preferences and customization	273
How do I?	
Customize Maya	273
Customize the look and feel of the interface	273
Show or hide user interface elements	273
Change user interface colors	273
Create a custom panel layout	274
Add a new panel to the list of available panels	275
Change the length (scale) of normals in the display	275
Customize shelves	276
Create, rename, rearrange, or delete a shelf	276
Add a tool, action, or MEL script to a shelf	277
Edit the MEL script associated with a shelf item	278

Table of Contents

	Edit the contents of a shelf	278
	Use a custom name or icon for a shelf item	279
	Change the display of shelves	279
	Customize marking menus and the hotbox	280
	Create or edit a marking menu	280
	Assign a marking menu to a hotkey	281
	Add a marking menu to the hotbox	282
	Customize the hotbox	283
	Customize hotkeys	284
	Assign a predefined command to a hotkey	284
	Assign a MEL script to a hotkey	285
	View a list of all assigned hotkeys	286
	Customize how Maya works	286
	Load or unload plug-ins	286
	Improve performance, quality, or interactivity	287
	Switch between Y-up and Z-up	287
	Customize the Maya Help	288
	Customize the Maya Help	288
	Customize the Maya Web browser	289
	Customize the Maya Web browser	289
	Advanced customization	289
	Directly modify the settings files	289
	Run MEL commands whenever Maya starts up	291
	Run MEL commands whenever a scene is opened or closed	291
	Create a custom heads-up display readout	291
Reference	Hotkeys	295
	View hotkeys	295
	Tool and action hotkeys	296
	Menus	298
	Window	298
	Window > Settings/Preferences > Preferences	298
	Window > Settings/Preferences > Colors	298
	Window > Settings/Preferences > Performance Settings	298

Table of Contents

Window > Settings/Preferences > Shelves	300
Window > Settings/Preferences > Marking Menus	302
Window > Settings/Preferences > Panels	302
Window > View Arrangement, Saved Layouts	302
Windows and Editors	302
Hotbox	302
Hotbox Controls > Hotbox Style	302
Windows and editors	303
Preferences	303
Marking Menus editor	325
Hotkey editor	329
Plug-in Manager	331
Index	335

1

Interface overview

About

Working in Maya

Maya is the premier application for creating compelling 3D digital content, including models, animation, visual effects, games, and simulations.

The work you do in Maya generally falls into these categories:

- Creating models. Polygons, NURBS, and subdivision surfaces are different object types with different ways of modeling. Each has its own strengths, and different artists prefer working with different types.
 - Polygons let you model a surface by building up and reshaping a number of simple surface facets.
 - NURBS let you easily create smooth, curving surfaces with high-level control.
 - Subdivision surfaces let you edit surfaces at a high level with minimum overhead data, while still letting you work with subsections of the surface as if they were made from polygons.
- Character rigging. Most animations involve “characters,” articulated models such as a person, an animal, robot, or anything else that moves by articulation. Maya lets you define internal skeletons for characters and bind skin to them to create realistic movement with deformation.
- Animation. Just about everything you can think of in Maya is keyable or able to be animated.
- Dynamics, fluids, and other simulated effects. Maya includes a comprehensive suite of tools for simulating real world effects such as fire, explosions, fluids, hair and fur, the physics of colliding objects, and more.
- Painting and paint effects. Maya includes an incredible system for using a graphics tablet (or the mouse) to paint 2D canvases, paint directly on 3D models, paint to create geometry, scriptable paint, and virtually limitless other possibilities.
- Lighting, Shading, and Rendering. When you want to render a still image or movie of you scene or animation, you can create them using your choice of renderers.

1 | Interface overview

About > 3D coordinates

3D

3D coordinates

The most basic visual entity is the *point*. The point has no size, but it has a *location*.

To determine the location of points, we first establish an arbitrary point in space as the *origin*.

We can then say a point's location is so many units left (or right) of the origin, so many units up (or down) from the origin, and so many units higher (or lower) than the origin.

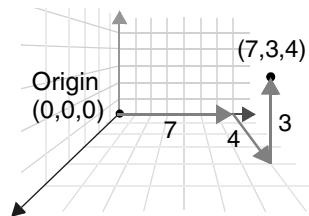

These three numbers give us the *3D coordinates* of the point in space. For example, a point 7 units *right* (*x*), 4 units *down* (*z*), and 3 units *above* (*y*) the origin has the XYZ coordinates (7,4,3).

To specify points on the opposite side of the origin, we use negative numbers. In the example, a point at (-5, -2, -1) would be 5 units *left* of the origin, 2 units *up*, and 1 unit *below*.

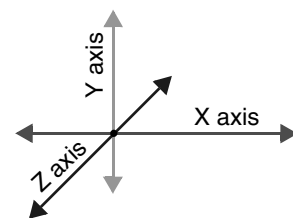

In computer graphics, we don't really say the point is "left/right", "up/down", or "higher/lower". Instead we call the three dimensions the *X axis*, the *Z axis*, and the *Y axis*.

Y-up and Z-up

In animation and visual effects, the tradition is to use Y as the "up" or elevation axis, with X and Z as the "ground" axes. However, some other industries traditionally use Z as the up axis and X and Y as the ground axes.

Maya lets you switch the up axis between Y and Z. Choose Windows > Settings/Preferences > Preferences, then click Settings in the list on the left.

❖ “Switch between Y-up and Z-up” on page 287

Maya’s Interface

Objects and components

In Maya, you model, animate, and render using *objects* such as spheres, NURBS surfaces, polysets, and so on. Objects are made up of or contain *components*, such as control points, patches, polygon faces, and so on.

Selection, tools, and actions

Selection

When you select multiple objects, the last selected object is drawn in a different color from other selected objects. This is known as the key object. Some tools use the key object to determine what to do with the selection. For example:

- When you transform multiple objects, the transformation uses the key object’s pivot point.
- The constrain actions constrain all selected objects to the key object.

Tools and actions

Maya makes a distinction between *tools* and *actions*.

- Tools work continuously: any clicks or drags you make in while the tool is active apply the tool.
For example, the selection arrow is a tool. Any clicks or drags in the view window while the selection arrow is active performs a selection.
- Actions are immediate, “one shot” operations applied to the selection. Most items in the menus are actions.

Tools appear in the toolbox. Almost all menu items are actions, however there are some tools in the menus. You can tell which menu items are tool by the following:

- The menu item has the word Tool in it.
- When you choose the tool it shows up in the toolbox.
- Instructions appear on the help line when the tool is active.

1 | Interface overview

About > Main window

Related topics

- ❖ "Select objects or components" on page 45
- ❖ "Choose tools and actions" on page 25

Main window

This section is a brief summary of Maya's main interface. As you read, keep in mind the following:

- You can show or hide any of the UI elements in the main window using the Display > UI Elements menu.
- You can also hide a UI element by clicking the hide button to the left of or above the UI element. To show a UI element, press the right mouse button on another hide button and select the desired UI element from the pop-up menu.
- You can hide all the interface elements and instead use Maya's quick command features: the Hotbox, Marking Menus, and hotkeys.
- A menu icon appears to the right of the mouse pointer when a right mouse button pop-up menu is available for the control over which the mouse is hovering.

1 | Interface overview

About > Main window

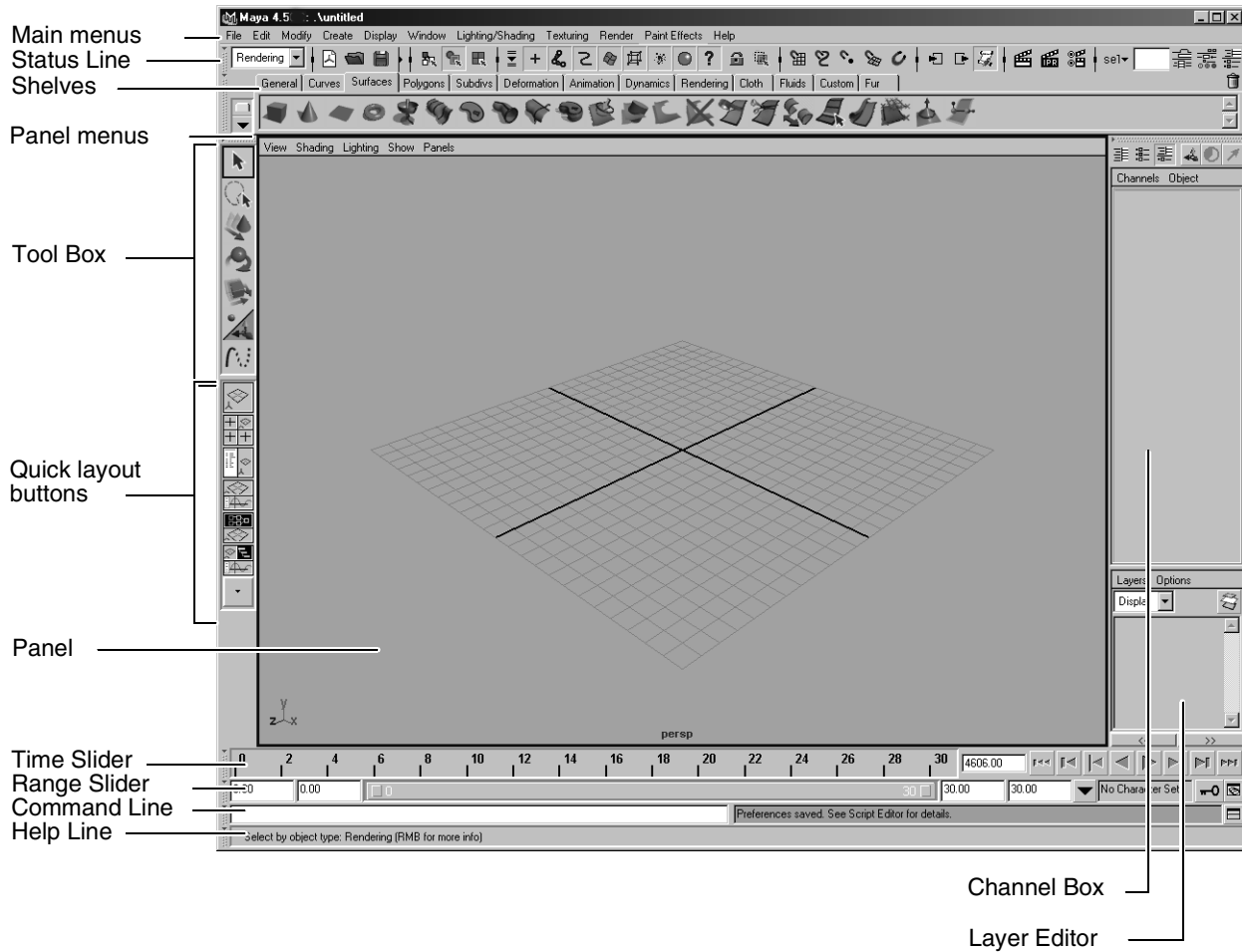

Status line (toolbar)

The status line (or toolbar) lets you

- Change the menu set.
- Access common functions.
- Control the selection mask.
- Set various options.
- Change the contents of the sidebar.

Related topics

- ❖ "Shelves" on page 22

1 | Interface overview

About > Menus and menu sets

- ❖ "Display > UI Elements" on page 41
- ❖ "Quick layout buttons" on page 69
- ❖ "Status line (toolbar)" on page 34
- ❖ "Command line" on page 37
- ❖ "Attribute Editor" on page 189
- ❖ "Channel Box" on page 196

Menus and menu sets

The menus in Maya are grouped into *menu sets*. Each menu set corresponds to a module of the software: Animation, Modeling, Dynamics, and Rendering. Maya Unlimited has additional modules: Cloth and Live. As you switch between menu sets, the right-hand menus change, but the left-hand menus remain the same; these are the common menus.

To switch between menu sets, use the Status Line pull-down menu or hotkeys. The hotkeys are: F2 (Animation), F3 (Modeling), F4 (Dynamics), and F5 (Rendering).

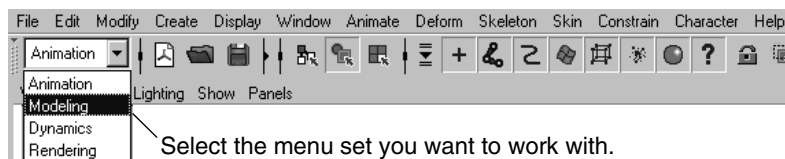

The common menus stay the same ... and these menus change

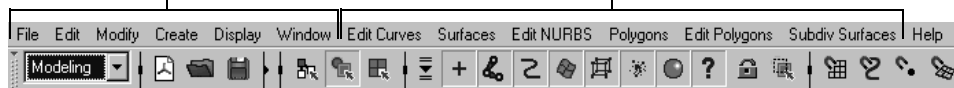

Tear-off menus

You can display menus as separate windows. This is helpful when you use a menu repeatedly. Pull down the menu and click the tear-off line at the top. Tear-off menus always display on top.

1 | Interface overview

About > Marking menus

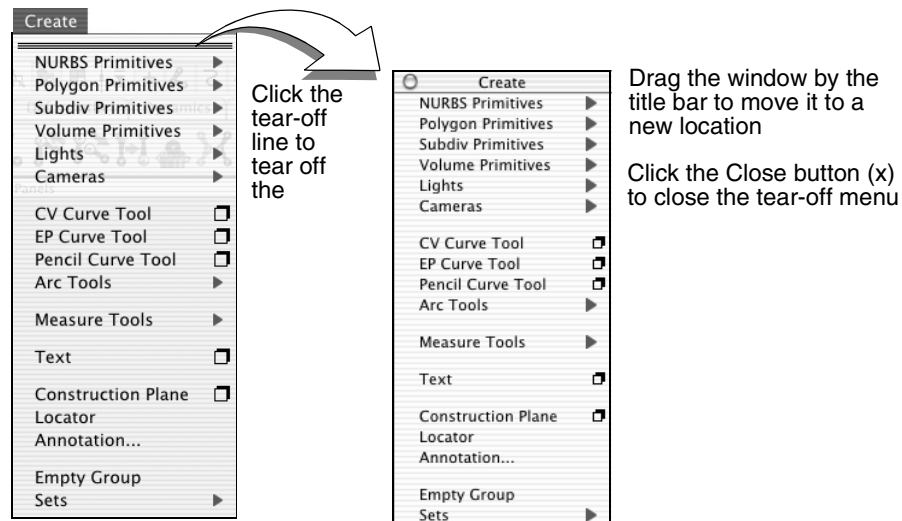

Related topics

- ❖ "Marking menus" on page 21
- ❖ "Choose tools and actions" on page 25

Marking menus

Marking menus allow very quick access to a few of your most commonly used tools.

Marking menus are used throughout the Maya interface. When you press the right mouse button on an object, a marking menu appears that lets you choose a selection mode and other options. Some marking menus appear when you hold a key and press a mouse button.

Marking menus are very fast for experienced users because once you get used to showing them and the positions of their items, you can select the items using very quick gestures with the mouse or tablet pen, sometimes so fast the entire menu won't even display.

Related topics

- ❖ "Choose actions from marking menus" on page 26
- ❖ "Create or edit a marking menu" on page 280
- ❖ "Assign a marking menu to a hotkey" on page 281
- ❖ "Add a marking menu to the hotbox" on page 282
- ❖ "Marking Menu editor" on page 325

1 | Interface overview

About > Shelves

Shelves

Shelves hold commonly used actions and tools, allowing them to be accessed by clicking an icon. You can also put custom scripts and panel layouts on a shelf.



Related topics

- ❖ "Choose actions on a shelf" on page 27
- ❖ "Create, rename, rearrange, or delete a shelf" on page 276
- ❖ "Add a tool, action, or MEL script to a shelf" on page 277
- ❖ "Edit the MEL script associated with a shelf item" on page 278
- ❖ "Edit the contents of a shelf" on page 278
- ❖ "Use a custom name or icon for a shelf item" on page 279
- ❖ "Change the display of shelves" on page 279

Web browser in a panel

This feature is supported on the Windows, Mac OS X, and Linux platforms.

You can use a Web browser within a Maya panel to browse through and view Web content, or issue MEL commands from an HTML page. This makes it possible to integrate Internet solutions into your Maya workflow.



This browser uses Gecko as a layout engine, employing Mozilla Open Source to properly display W3C compliant Web content. This means that you can add plugins to view Flash movies or do any of the other activities you're used to doing from a Web browser window, all from a panel

within the Maya interface. Just like any other Maya panel, the Maya browser can be placed in the main Maya window beside other panels, or into a separate window.

The Maya browser does not provide all of the features supported by your current Web browser, and is not intended as a replacement. For example, it won't create multiple windows or popup windows, so links that create and open new windows will not work. As well, secure sites are not supported for this release.

Examples of workflow

The Maya browser makes it easier for you to view Web content while you work in Maya, without having to flip between browser windows and the Maya interface. Some examples of what you can view from within your Maya window include:

- Help and tutorials, with the Maya interface in front of you to use while you follow instructions or look for interface controls
- Flash content that you've exported from Maya
- 2D images from the Internet (or from your organization's intranet) that you can compare with models you are creating in Maya
- Project criteria on the Web that you're using to construct models, animations, and renderings

By issuing MEL commands from the Maya browser, you can:

- Design your own user interface for Maya using HTML and JavaScript
- Set up multiple controls (widgets) within HTML pages for easy reference, comparison, or tweaking of Maya characters
- Set up custom MEL tools to share over the Internet, or to interface with custom pipeline tools such as render farms

Related topics

- ❖ "Use the Maya browser" on page 31
- ❖ "Configure the Maya browser" on page 32
- ❖ "Maya Browser (Web browser in a panel)" on page 38

1 | Interface overview

How do I? > Get help

How do I? Get help

To...	Do this
Show the online help in a browser.	Choose Help > Maya Help, or press F1.
Show the help for a window.	Choose an item in the window's Help menu.
Find a tool or menu item in the interface.	Choose Help > Find menu.
Get a description of/ instructions for the action under the mouse pointer.	Look in the help line.

Print the Maya Help

The Maya Help is also provided in PDF format. You can print the online books using Adobe Acrobat Reader, available free from Adobe at www.adobe.com.

To print the online books (Windows, Mac OS X)

- 1 Insert the Documentation, Lessons, and Extras CD.
- 2 Navigate to the /pdf directory.
- 3 Double-click to open `contents.pdf`. This file lists all of the available books.
- 4 Click to select the book you want to print. The selected PDF document opens.
- 5 Select File > Print.

To print the online books (IRIX)

- 1 Insert the Documentation, Lessons, and Extras CD.
- 2 Start Adobe Acrobat Reader and open `/CDROM/pdf/contents.pdf` by entering the following:

```
cd /CDROM/pdf
acroread contents.pdf
```
- 3 Click to select the book you want to print. The selected PDF document opens.
- 4 Select File > Print.

To print the online books (Linux)

- 1 Insert the Documentation, Lessons, and Extras CD.
- 2 Start the PDF viewer and open `/mnt/cdrom/pdf` by entering the following:

```
cd /mnt/cdrom/pdf
xpdf contents.pdf
```
- 3 Click to select the book you want to print. The selected PDF document opens.
- 4 Select the print icon.

Work with menu items, tools, and options

Choose tools and actions

To use a tool

- Click a tool in the toolbox to make it active.
- Double-click a tool to show the tool's options panel.

To use an action (menu item)

- Click a menu item to perform the action on the selected objects or components.

Some actions work differently depending on the order you select the objects. For example, you select all the objects you want to constrain, and then select the object to constrain to last when you create a constraint.

The help line for an action tells you the order you need to select objects if order is important.

- Click the box next to the name of a menu item to open the action's options window.
- Click the lines at the top of a menu or sub-menu to keep the menu open in its own window.

To reset a tool or action to its original ("factory") options

- In the option window, choose Edit > Reset settings.
- In the Tool Settings editor, click Reset Tool.

1 | Interface overview

How do I? > Set the options for a tool or menu item

Related topics

- ❖ "Selection, tools, and actions" on page 17
- ❖ "Menus and menu sets" on page 20

Set the options for a tool or menu item

- Click the box next to the name of a menu item to open the action's options window.
- Double-click a tool to show the tool's options panel.

To reset a tool or action to its original ("factory") options

- In the option window, choose Edit > Reset settings.

Choose actions from marking menus

Marking menus appear at the mouse pointer when you use certain key and mouse button combinations. They allow you to quickly choose an action from a small list.

Marking menus are common in the Maya interface:

- When you press the right mouse button on an object Maya shows a context-sensitive marking menu of actions you can apply to the object.
- The hotbox provides five customizable marking menus you can show by clicking inside, above, below, left, or right of the hotbox menus.
- You can assign marking menus to hotkeys. Hold the key and press the mouse button to show the marking menu.
The q, w, e, and r keys have default marking menus attached to them.
- Marking menu items can show additional marking menus, allowing you to pack more commands onto the marking menu.

To choose an item from a marking menu

- 1** Show the marking menu through one of the methods listed above (for example, hold q and press the left mouse button).
- 2** With the mouse button held, drag in the direction of the item you want to choose.

It doesn't matter how far you drag or if you hit the item exactly. This allows you to make the drag very quickly with a little practice.

Dragging over an item with a submenu attached shows the submenu.

- 3** Release the mouse button to choose the item.

Related topics

- ❖ "Marking menus" on page 21
- ❖ "Choose actions from the hotbox" on page 27
- ❖ "Create or edit a marking menu" on page 280
- ❖ "Assign a marking menu to a hotkey" on page 281
- ❖ "Add a marking menu to the hotbox" on page 282
- ❖ "Marking Menus editor" on page 325

Choose actions from the hotbox

The hotbox contains every action available in the Maya interface. It appears when you hold down the space bar.

The hotbox has three main functions:

- It contains every menu and menu item. This is useful if you want to quickly use an action from another menu set without switching menu sets.
- You can use the hotbox to choose actions even if you've hidden the menu bar and other UI to save space.
- The hotbox provides five customizable marking menus you can show by clicking inside, above, below, left, or right of the hotbox menus.

To choose an action from the hotbox

- 1** Hold the space bar to show the hotbox. The hotbox remains on screen as long as you hold the space bar.
- 2** Click one of the menus, or hold the left mouse button above, below, to the left, to the right, or in the center of the hotbox to show marking menus.

Related topics

- ❖ "Add a marking menu to the hotbox" on page 282
- ❖ "Customize the hotbox" on page 283

Choose actions on a shelf

- Click an icon on the shelf to perform the action.
- Click a tab above the icons to show a different shelf.
- Use the pull down menu to the left of the icons (the black arrow) to show or hide the tabs.

1 | Interface overview

How do I? > Load the default shelves

- If the tabs are hidden, or if there are too many to fit on screen, click the tab icon to the left of the icons to show a menu of available shelves.

Click to switch between shelves

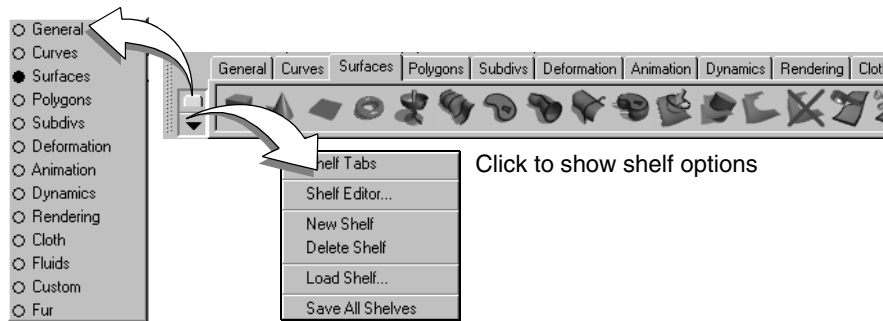

- Drag menu items or snippets of code onto a shelf with the middle mouse button.

Load the default shelves

Maya for Windows and Mac OS X include default shelves with buttons for commonly used features. The shelves are: Animation, Cloth, Curves, Custom, Deformation, Dynamics, Fluids, Fur, General, Hair, Paint Effects, Polygons, Rendering, Subdivs, and Surfaces.

Maya does not include the shelves in IRIX and Linux because they can slow the startup time on those platforms. However you can use the following instructions to load them.

- 1 Open the Script Editor (Window > General Editors > Script Editor).
- 2 To load all shelves, copy the following and paste it into the Script Editor window, then select Script > Execute. (Select only some shelves from the list below if you do not want to load them all by default.)

```
loadNewShelf "shelf_General.mel";
loadNewShelf "shelf_Curves.mel";
loadNewShelf "shelf_Surfaces.mel";
loadNewShelf "shelf_Polygons.mel";
loadNewShelf "shelf_Subdivs.mel";
loadNewShelf "shelf_Deformation.mel";
loadNewShelf "shelf_Animation.mel";
loadNewShelf "shelf_Dynamics.mel";
loadNewShelf "shelf_Rendering.mel";
loadNewShelf "shelf_Cloth.mel";
loadNewShelf "shelf_Fluids.mel";
loadNewShelf "shelf_Fur.mel";
loadNewShelf "shelf_Hair.mel";
```

```
saveAllShelves $gShelfTopLevel;
```

Related topics

- ❖ "Main window" on page 18
- ❖ "Create, rename, rearrange, or delete a shelf" on page 276
- ❖ "Add a tool, action, or MEL script to a shelf" on page 277
- ❖ "Edit the contents of a shelf" on page 278
- ❖ "Window > Settings/Preferences > Shelves" on page 300

Start Maya from the command line

If you start Maya from the command line, there are various startup options you can specify. For example, you can open a file at startup using the `-file` flag:

```
maya -file filename
```

To see the available startup flags, type the following:

```
maya -help
```

Running Maya in batch or prompt mode

Maya can be run in several distinct modes that affect its overall manner of operation, two of which allow you to execute Maya commands without the interface, `-prompt` and `-batch`.

- The `-prompt` flag issues a MEL prompt for you to type commands as you would in the Script Editor. Some commands that require the graphical user interface are either unavailable or have no effect. Type `quit` to exit the prompt mode.
- Use the `-batch` flag to run commands without user input, such as in shell or batch scripts. The `-batch` flag starts Maya, executes any commands you specify, and then closes Maya. For example, you could create a script to open a file from a prior version of Maya in order to update it to the current version:

```
maya -batch -file someMayaFile.mb -command "file -save"
```

There is an example of simulating Cloth in batch mode. See "*Simulate cloth in batch mode*" on page 119 of the Cloth guide.

Additional Maya startup flags

These are additional flags you can use when starting up Maya from the command line.

1 | Interface overview

How do I? > Start Maya from the command line

<code>-archive [file]</code>	Displays a list of files required to archive the specified scene and then exits Maya.
<code>-command [mel command]</code>	Runs the specified command on startup. The command should be enclosed in double quotes to protect any special characters, including spaces.
<code>-log [file]</code>	Copies all error, warning, and information messages (those that normally appear in the Script Editor window) to the specified file (use complete file name).
<code>-optimizeRender [file] [outfile]</code>	Processes the specified scene file to optimize it for rendering, puts the result in outfile and then exits. Use <code>maya -optimizeRender -help</code> for more options. See “-optimizeRender flags” on page 31.
<code>-proj [dir]</code>	Looks for scene files in the specified project directory.
<code>-recover</code>	Recovers the last journal file.
<code>-render [file]</code>	Renders the specified Maya scene file (either a single frame or a sequence of frame, depending on the render globals settings or other command-line flags specific to the <code>-render</code> option) and then exits. Use <code>Render -help</code> for more options.
<code>-script [file]</code>	Sources the specified file (which is expected to be a MEL script) on startup.
<code>-v</code>	Displays the product version and cut number, and then exits.

Notes The `-batch` command is not used for batch rendering. Instead, use the `Render` command. However, `-batch` does check out a render-only license instead of a full Maya license.

On Windows, type `mayabatch` when using the `-batch` flag. The `mayabatch` command runs within the command prompt window, whereas the `maya` command starts a separate window.

-optimizeRender flags

Use this command to optimize the specified scene file for rendering, send the result to an output file and then close Maya.

```
maya -optimizeRender [options] [file] [outfile]
```

The available [options] are:

-botRes [int]	Specify a minimum file texture resolution that will cause BOT files to be produced. For example, specifying “-botRes 256” means that all file textures bigger than 256x256 will be converted to BOT format.
-botLoca [name]	Specify the directory in which BOT files reside. The default is in the same directory as the original file.
-help	Displays all the flags available for use with -optimizeRender.
-noBOT	Does not create BOT files.
-noCleanup	Does not clean up useless data.
-tessFreeze [startframe] [endframe] [byframe]	Calculates NURBS tessellation that gives the best image quality based on the camera projection.

Use the Maya browser

To access the Maya browser

- 1 Do one of the following:
 - From any Maya panel, select **Panels > Panel > Web Browser**. The browser appears in the Maya panel.
 - Right-click a Quick Layout button and select the Web Browser Panel menu item:

1 | Interface overview

How do I? > Configure the Maya browser

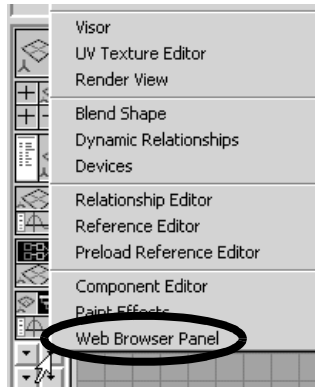

2 Type in a URL or MEL command in the entry field.

- Precede URLs with `http://`
- Precede MEL commands with `mel://`

Related topics

- ❖ "Web browser in a panel" on page 22
- ❖ "Configure the Maya browser" on page 32
- ❖ "Maya Browser (Web browser in a panel)" on page 38

Configure the Maya browser

If you are on a LAN, you may need to set up one or more proxies to access external Internet servers. If you don't know the name or port number of your proxy server, check the settings of your current browser, or contact your LAN administrator.

To configure the Maya browser for use with a network proxy

- 1** Select **Window > Settings/Preferences > Preferences**.
The Preferences dialog box appears.
- 2** Under Settings, select **Web Browser** from the Categories list.
- 3** Type in the appropriate settings under **Network Configuration**. You can choose from **Direct Connection**, **Manual Proxy** (which you must specify), or **Automatic Proxy**.

1 | Interface overview

How do I? > Configure the Maya browser

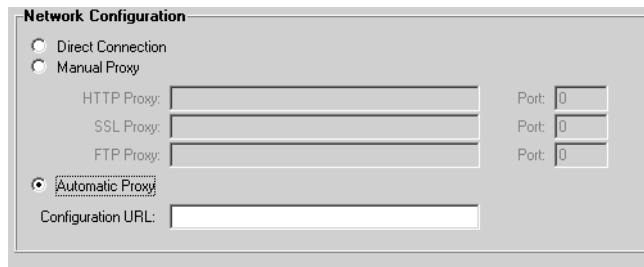

4 Click Save.

To set whether the Maya help opens in the Maya browser or an external browser

1 Select Window > Settings/Preferences > Preferences.

The Preferences dialog box appears.

2 Select Misc from the Categories list.

3 In the Help Browser section, select one of the following:

- Open Help In Main Maya Window – select this to launch the Maya online help in a panel
- Open Help Using External Browser – select this to launch the Maya online help in your default Web browser (default)

4 Click Save.

To set the home page

1 Select Window > Settings/Preferences > Preferences.

The Preferences dialog box appears.

2 Select Settings > Web Browser from the Categories list.

3 Type in the URL of the new home page, or click Use Current Page.

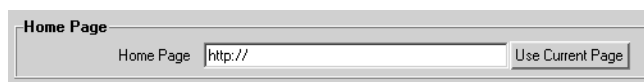

4 Click Save.

Related topics

- ❖ "Web browser in a panel" on page 22
- ❖ "Use the Maya browser" on page 31
- ❖ "Maya Browser (Web browser in a panel)" on page 38

1 | Interface overview

Reference > Status line (toolbar)

Reference Tools

Status line (toolbar)

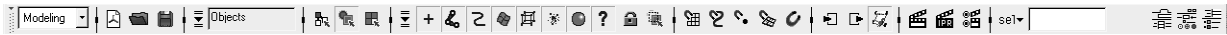

Menu set menu



- ❖ "Menus and menu sets" on page 20
- ❖ "Choose tools and actions" on page 25

File buttons



These buttons let you start a new scene file, open an existing scene file, or save the current scene file.

- ❖ "Create, open, or save a scene file" on page 219

Selection mask

The toolbar contains several different controls to change the selection mask. The selection mask determines what type of objects or components you can select.



The selection mode menu lets you choose common preset selection masks.



The selection mode buttons let you switch between Select by hierarchy and combinations mode, Object mode, and Component mode.



The selection mask buttons let you make specific object/component types selectable or unselectable.

- ❖ "Selection, tools, and actions" on page 17
- ❖ "Select objects or components" on page 45
- ❖ "Select only certain types of objects or components (selection masks)" on page 48

Selection options



Click the lock to lock the selection so the left mouse button operates the manipulator instead of selecting. Click the lock again to unlock the selection.

- ❖ "Select objects or components" on page 45

Snapping buttons



Snap to grids

Snaps a vertex (CV or polygonal vertex) or pivot point to a grid corner. If you select Snap to grids before you create a curve, its vertices snap to the grid corners.

Snap to curves

Snaps a vertex (CV or polygonal vertex) or pivot point to a curve or curve on surface.

Snap to points

Snaps a vertex (CV or polygonal vertex) or pivot point to a point.

Snap to view planes

Snaps a vertex (CV or polygonal vertex) or pivot point to a view plane.

- ❖ "Snap to the grid, a curve, points, or a view plane" on page 116
- ❖ "Snap all creation tools to a surface or construction plane" on page 117

1 | Interface overview

Reference > Status line (toolbar)

Render buttons



Click these buttons to perform a normal render, perform an IPR render, or open the render global settings window.

Input box



Use the menu on the left to choose what the input box does.

Quick Selection (sel)

Type the name of an object to select it. Use wildcards (* and ?) to select multiple objects.

- ❖ "Select objects or components" on page 45

Quick Rename (nam)

Edit the name of the currently selected object. When more than one object is selected, Maya increments a number at the end of the name for each object.

- ❖ "Change the name of one or more objects" on page 224

Numeric input: Absolute (abs)

Type numbers to move to, scale to, rotate to, etc., based on the transformation tool currently selected.

Numeric input: Relative (rel)

Type numbers to move by, scale by, rotate by, etc., based on the transformation tool currently selected.

- ❖ "Move, rotate, or scale objects" on page 110

Sidebar buttons



Click a button to show a sidebar:

- Attribute Editor/notes
- Settings for the current tool
- Channel Box/Layer Editor

Command line

The command line lets you type single MEL commands without having to open the Script Editor. The result from the command appears in the output

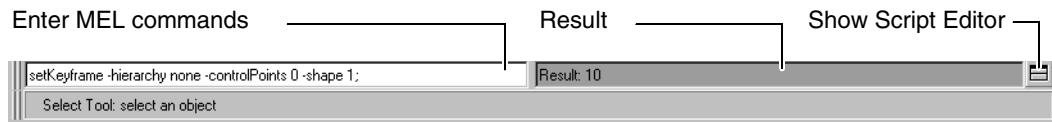

Type MEL commands in the command line. The result appears in the colored box to the right of the command line.

- To enter more complex scripts, click the Script Editor button to the right of the result box.
- Drag the divider between the input and result boxes to resize them.

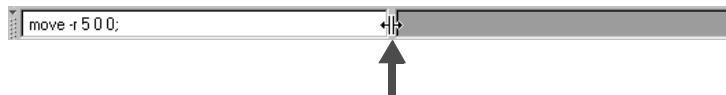

- When the cursor is in the command line, press up and down to scroll through the command history.

Toolbox

Select tool

Lets you select objects and components in view panels and the texture editor.

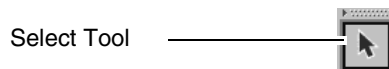

The select tool has no options when you use it in view panels. When you work in a texture editor panel the move tool has texture editor specific options.

Related topics

- ❖ "Selection, tools, and actions" on page 17
- ❖ "Select objects or components" on page 45

Lasso tool

Lets you select objects and components in view panels by drawing a freeform shape around them.

1 | Interface overview

Reference > Show Manipulator tool

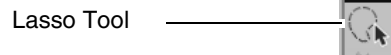

Draw Style

- | | |
|--------|---|
| Open | As you draw the lasso, the shape remains open. |
| Closed | As you draw the lasso, Maya connects the end and start points to show the enclosed space. |

Component Selection

- | | |
|----------|---|
| Fast | Uses an approximation of the lasso shape to select components slightly faster when you release the mouse button. |
| Accurate | Uses the exact shape of the lasso, but can take slightly longer to select components when you release the mouse button. |

On modern machines there is very little difference in speed between Fast and Accurate component selection.

Related topics

- ❖ "Selection, tools, and actions" on page 17
- ❖ "Select objects or components" on page 45

Show Manipulator tool

Shows a manipulator tailored for the selected node or attribute.

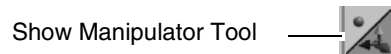

Related topics

- ❖ "Use manipulators" on page 107
- ❖ "Show a custom manipulator for the selected node" on page 122

Windows and editors

Maya Browser (Web browser in a panel)

Related topics

- ❖ "Web browser in a panel" on page 22
- ❖ "Use the Maya browser" on page 31
- ❖ "Configure the Maya browser" on page 32

Maya browser controls

The following controls are available in the Maya browser:

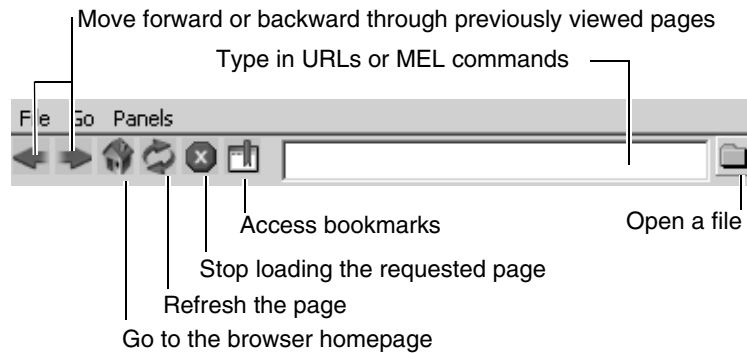

Web browser menu items

File > Open

Lets you load a particular file.

File > Reload

Reloads a page with its latest version (to ensure that you're not viewing a cached page).

File > Stop Loading

Stops the loading of a page.

Go > Back

Goes to previous pages.

Go > Forward

When you are browsing through previous pages, goes to pages you had viewed subsequently.

Go > Home

Goes to the browser home page.

Examples of MEL Commands in the browser

You can communicate with Maya from its Web browser by using MEL commands, which you must precede by `mel://`

The following examples of Maya browser MEL code could be used in a Web page. They produce links that you click in the Maya browser to create and move a cube and a sphere.

1 | Interface overview

Reference > Maya Help search engine

```
<a href="mel://nurbsCube/">Create default cube</a><br>
<a href="mel://sphere -radius 3/">Create sphere with radius 3</a><br>
<a href="mel://select nurbsCube1/">Select cube</a><br>
<a href="mel://move -x 5/">Move cube 5 units along X axis</a><br>
<a href="mel://select nurbsSphere1">Select sphere</a><br>
<a href="mel://sphere -edit -radius 8 nurbsSphere1/">Change radius of sphere to 8</a><br>
```

Maya Help

Maya Help search engine

The Maya Help search engine is based on Lucene (jakarta.apache.org/lucene/). It provides powerful, accurate, and efficient searches. This section gives more details on how the Maya Help search engine works, so you can get maximum use out of the Maya Help system.

Default search

The Maya Help search engine creates an OR search by default; that is, it matches *any* word specified. If you do a search for `render lights`, the search engine finds all documents that contain `render` *and* all documents that contain `lights`. It boosts all documents that contain both terms to the top of your search results, but it also finds all documents that contain only one or the other search term.

This means that simply adding terms won't make your query more constrained; it will make more results appear, as the number of pages with *any* of those terms get larger and larger. To constrain your multiple-word query, use the `+` symbol before the search terms, which tells the search engine that word or phrase *must* appear in the result.

Stemming searches

One of the features of the Maya Help search engine is that it automatically performs a case-insensitive search for all grammatical variants of a word, to get maximally useful search results.

Searching for `render` also returns search results for `renders`, `rendering`, `rendered`, etc.

Other search features

- Search terms appearing in the title of a document cause the matched document to appear higher in the list of search results, compared to a match in the body of a document.
- Search terms appearing in the Glossary cause the matched document to appear higher in the list of search results.

- The Maya Help search engine compares your search against a dictionary of common words to help catch misspellings and typos.
- If no term is matched, the Maya Help search engine automatically performs a fuzzy search to find closely-matching terms.

Related topics

- ❖ “Maya Help search tips” on page 42

Menus

Edit

Edit > Undo, Redo, Repeat

- ❖ “Undo, Redo, and Repeat” on page 121

Modify

Modify > Make Live

Converts the selected surface to a “live surface”. For NURBS surfaces, curves drawn on a live surface become curves-on-surface. All other creation tools automatically snap to the live surface.

Choose this item again to turn it off.

Related topics

- ❖ “Snap all creation tools to a surface or construction plane” on page 117

Display

Display > UI Elements

The items in this menu control the visibility of various user interface parts.

Hide UI Elements

Hide all UI parts so only the panels and menus are visible.

Show UI Elements

Show *all* UI parts.

1 | Interface overview

Reference > Window > Settings/Preferences > Tool Settings

Restore UI Elements

Restores the visibility of UI parts to their state before you selected Hide UI Elements. If certain parts were hidden before you selected Hide UI Elements, they will still be hidden.

Related topics

- ❖ "Main window" on page 18

Window

Window > Settings/Preferences > Tool Settings

Shows the options for the current tool in a window. If the tool options are already visible in the side panel, Maya closes the side panel first.

Related topics

- ❖ "Selection, tools, and actions" on page 17
- ❖ "Choose tools and actions" on page 25

Tips

Maya Help search tips

Related topics

- ❖ "Maya Help search engine" on page 40

You can use the following special syntax in your search query for more exact searches.

Search for a phrase

Enclose the words in quotation marks ("").

Example

```
"test render"  
"curve on surface"
```

Require or exclude terms

Type a plus (+) before a term to require that all results contain that term.
Type a minus (-) before a term to exclude all results that contain that term.

Example

Find both polygon and NURBS:

```
+polygon +nurbs
```

Find test but not render:

```
test -render
```

Perform boolean searches

Use (), AND, OR, and NOT to group terms into boolean searches.

Example

```
(polygon AND nurbs) OR subdivision
```

Search using wildcards

Use a question mark (?) to match a single character. Use an asterisk (*) to match any characters. You cannot use a * or ? symbol as the first character of a search.

Example

```
poly*
```

matches polygons, polys, polygonal, all nodes starting with poly-.

```
d?ne
```

matches done, dune, dine.

```
r*ing
```

matches rendering, running.

Match a word that's close to your search word

Type a tilde (~) at the end of a word to allow fuzzy matches of that word. Note: fuzzy matches are not ranked as high in the search results as exact matches.

Example

```
subd~
```

matches subds, subdivision, all nodes starting with subd-.

Make some terms more important than others

Type a caret (^) at the end of a word or phrase followed by a number (typically between 1 and 5). Higher numbers make that word more important in the ranking of search results.

1 | Interface overview

Reference > Maya Help search tips

Example

```
test render^2  
"shadow pass"^3
```

Search for special characters

To search for strings containing special characters, for example, \, :, or -, put quotes (") around the entire string or use \ before the character.

Example

```
"C:\Program Files\  
"anti-aliasing" or anti\-aliasing
```

Search a subsection of the Maya Help

You can search particular sections of the Maya Help by adding `+section:"<section_name>"` to your query, where `<section_name>` is `What's New` or `Tutorials`.

You can also search in a book in the Using Maya documentation, by adding `+module:"<book_name>"`; for example: `+module:"Rendering"`

You'll get best results when doing a section or module search when you use a + sign in front of the word you're looking for; for example, `+fur+section:"What's New"` finds everything new about Fur.

2 Selecting

How do I? **Select**

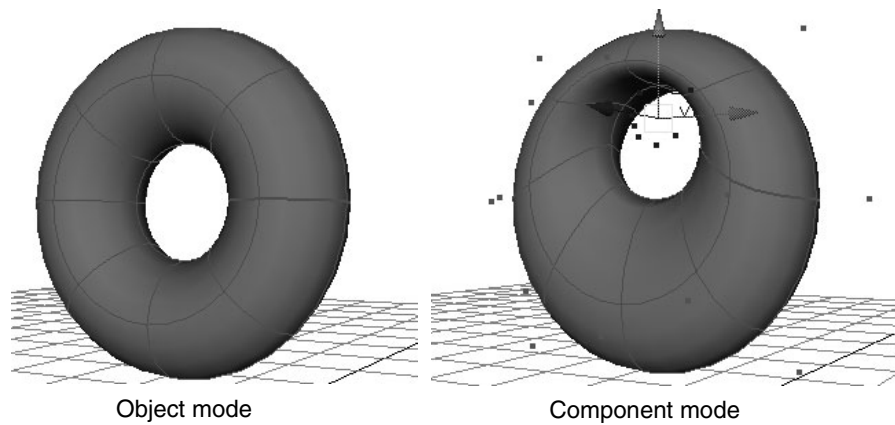

Select objects or components



To...	Do this
Select by clicking or dragging.	Click the Select tool in the toolbox. or Press q.
Select an object/ component.	Click the left mouse button.
Select multiple objects/ components.	Drag a selection box/lasso around the objects/components, or hold Shift and click.
Deselect objects/ components.	Hold Ctrl and click or drag.
Select by drawing selection lasso.	Click the Lasso tool in the toolbox.
Show a marking menu of options and actions related to selection.	Hold q and press the left mouse button.

2 | Selecting

How do I? > Select objects or components

To...	Do this
Select objects.	<p>Click the “Select by object type” icon in the toolbar.</p>  <p>or</p> <p>Press the right mouse button on an object and choose Object Mode from the marking menu.</p>
Select components.	<p>Click the “Select by component type” icon in the toolbar.</p>  <p>or</p> <p>Press the right mouse button on an object and choose a component type from the marking menu.</p> <p>or</p> <p>Press F9 (vertices), F10 (edges), F11 (faces), or F12 (UVs).</p>
Toggle between selecting object and component.	Press F8.
Select an object by name.	<p>Open the drop-down list next to the input box on the status line and choose Quick Selection.</p>  <p>In the input field, type the name of the object.</p> <p>Use wildcards (* and ?) to select multiple objects. “*” matches any string of characters. “?” matches any single character.</p>
Select all objects.	Choose Edit > Select All.
Select all objects of a certain type.	Choose an item in the Edit > Select All by Type submenu.

To...	Do this
Invert the selection. (Select all unselected objects, and deselect all selected objects.)	Choose Edit > Invert Selection.

Selecting specific component types

The following table has tips for selecting certain types of components. They follow the same general pattern for selecting components, but demonstrate some selection techniques or component types that may not be obvious.

To...	Do this
Select polygon faces.	Press the right mouse button on a polyset and choose Face, or press F11. Select the dots in the center of the faces.
Select an arbitrary point on a curve.	Press the right mouse button on a curve and choose Curve Point. Press the left mouse button on the curve and drag to select a point along the curve.
Select an isoparm on a surface.	Press the right mouse button on a surface and choose Isoparm. Press the left mouse button on a visible isoparm that runs in the direction you want, then drag to the position you want.
Select an arbitrary point on a surface.	Press the right mouse button on a surface and choose Surface Point. Press the left mouse button on an isoparm and drag to select a point on the surface.
Select a NURBS surface patch.	Press the right mouse button on a NURBS surface and choose Surface Patch. Select the dots in the center of the patches.

Related topics

- ❖ "Selection, tools, and actions" on page 17

2 | Selecting

How do I? > Select a node

- ❖ "Edit > Select All, Select Hierarchy, Invert Selection" on page 52
- ❖ "Edit > Select All by Type" on page 53

Select a node

To select a node, do any of the following:

- Select an object with which the node is associated, click the node's tab in the Attribute Editor, and click the Select button at the bottom of the Attribute Editor.
- Select an object with which the node is associated, then click the node's heading in the Channel Box.
- Open the Hypergraph (Windows > Hypergraph) and choose Graph > Input and Output Connections. Then click the node in the graph.

With a node selected, you can click the Show Manipulators tool in the toolbox to show custom manipulators for the node.

Related topics

- ❖ "Select objects or components" on page 45
- ❖ "Nodes and attributes" on page 149

Select only certain types of objects or components (selection masks)

You can limit the types of objects or components Maya selects when you click or drag with the selection tools. This lets you work on certain parts of a complex model without accidentally selecting other objects.

To limit selections, you choose which types of objects or components you can and can't select. This is called the *selection mask*.

To...	Do this...
Switch between selecting objects and components.	Use the Select by object type and the Select by component type icons in the toolbar. The icons available in the selection mask depend on whether you are in object or component selection mode.
Turn a object/ component type on or off in the selection mask.	Click the type icon in the selection mask area of the toolbar. When an icon is depressed, that type is selectable.

To...	Do this...
Set the selection mask to all types.	Press the left mouse button on the pop-up menu icon to the left of the selection mask and choose All Objects/Components On.
Clear the selection mask.	Press the left mouse button on the pop-up menu icon to the left of the selection mask and choose All Objects/Components Off. When all types are off, you cannot select anything. Make sure to turn at least one type on again if you want to select.
Set the selection mask to a preset combination of objects and components based on workflow.	<p>If the area to the left of the selection mode icons on the toolbar is hidden, click the bar to expand it.</p>  <p>Click the bar to expand</p> <p>Press the left mouse button on the pop-up menu icon and choose a workflow. The selection mask is set to objects and components related to that workflow.</p>

Related topics

- ❖ "Select objects or components" on page 45
- ❖ "Status line (toolbar)" on page 34

Save and reuse a selection

Quick-select sets are useful to:

- Make it easier to quickly select commonly used sets of objects/components.
- Save a complex selection so you can re-use it later without having to reselect each object.

To create a quick-select set

- 1 Select the objects or components.
- 2 Choose Create > Sets > Quick Select Set.
- 3 Type a name for the set.

2 | Selecting

How do I? > Select objects based on hierarchy

To select the members of a quick-select set

- Choose the set in the Edit > Quick Select Sets submenu.

To edit the membership of a quick-select set

- Use the Relationship Editor to control which objects are in a quick select set.

Related topics

- ❖ "Edit > Quick Select Sets" on page 53
- ❖ "Create > Sets > Quick Select Set" on page 55

Select objects based on hierarchy

To set the selection mask to only select top level nodes (roots)

- 1 Click the Select by hierarchy and combinations icon in the toolbar.



- 2 Set the selection mask to Root.

To set the selection mask to only select only nodes without children (leaves)

- 1 Click the Select by hierarchy and combinations icon in the toolbar.



- 2 Set the selection mask to Leaf.

To select all nodes under the selected node

Choose Edit > Select Hierarchy.

Related topics

- ❖ "Select objects or components" on page 45
- ❖ "Edit > Select All, Select Hierarchy, Invert Selection" on page 52

Select components by painting

You can select components such as vertices or faces by painting over the components with your graphics tablet pen.

- 1 Select the object on which you want to select components.

How do I? > Change one type of selection to another

- 2** Choose Edit > Paint Selection Tool > □.
- 3** Use the tool options panel to set up the tool, including choosing whether you are selecting, deselecting, or toggling components between selected and unselected.
- 4** Set up the selection mask to choose what types of components you want to select.
- 5** Paint on the selected object to select components.

Change one type of selection to another

When you have one type of component selected you can automatically select a corresponding component of a different type. For example, you can select a face and then use Convert Selection to Edges to select the edges around the face.

The Convert Selection... type menu items do not change or convert the actual geometry. They only change which components are selected.

- To change polygon selections, use the Convert... items in the Edit Polygons > Selection submenu.
- To change subdivision surface selections, use the Convert... items in the Subdiv Surfaces menu.

Related topics

- ❖ "Select objects or components" on page 45

Grow, shrink, or change the selected region of CVs or polygon components**Polygon components**

To...	Do this
Grow or shrink a selection.	<ul style="list-style-type: none"> • Chose Edit Polygons > Selection > Grow Selection Region. • Chose Edit Polygons > Selection > Shrink Selection Region.
Select the components around the current selection.	Chose Edit Polygons > Selection > Select Selection Boundary.

2 | Selecting

Reference > Edit > Select All, Select Hierarchy, Invert Selection

To...	Do this
Select all edges connected to the current selection.	Chose Edit Polygons > Selection > Select Contiguous Edges.

NURBS CVs

To...	Do this
Grow or shrink a selection.	<ul style="list-style-type: none">• Chose Edit NURBS > Selection > Grow CV Selection.• Chose Edit NURBS > Selection > Shrink CV Selection.
Select the CVs around the current selection.	Chose Edit NURBS > Selection > Select CV Selection Boundary.
Select CVs on the edges of the surface.	Chose Edit Polygons > Selection > Select Surface Border.

Related topics

- ❖ "Select objects or components" on page 45

Reference Menus

Edit

Edit > Select All, Select Hierarchy, Invert Selection

- Select All selects all objects in the scene.
- Select Hierarchy selects all parent and child objects of the current selection.
- Invert Selection selects all unselected objects, and deselects all selected objects.

Related topics

- ❖ “Select objects or components” on page 45
- ❖ “Select objects based on hierarchy” on page 50

Edit > Select All by Type

The items in this submenu select every object of a certain type in the scene.

Related topics

- ❖ “Select objects or components” on page 45

Edit > Quick Select Sets

The items in this submenu correspond to the quick selection sets you create with Create > Sets > Quick Select Set. Use this menu to quickly switch between common selections.

Related topics

- ❖ “Save and reuse a selection” on page 49
- ❖ “Create > Sets > Quick Select Set” on page 55

Edit > Paint Selection Tool

Lets you select components by painting over them with the stylus. See also “*How Artisan brush tools work*” in the Paint Effects, Artisan, and 3D Paint guide.

Related topics

- ❖ “Select components by painting” on page 50

Edit > Paint Selection Tool > □

The options described below are unique to the Paint Selection Tool. Descriptions of the rest of the options and sections in the Paint Selection Tool settings editor can be found in “*Common Artisan Brush Tool Settings*” in the Paint Effects, Artisan, and 3D Paint guide.

Paint Operations

Select one of the following paint operations.

- | | |
|----------|--|
| Select | Selects painted components. |
| Unselect | Unselects selected painted components. |

2 | Selecting

Reference > Edit > Paint Selection Tool

Toggle

Unselects selected components and selects unselected components.

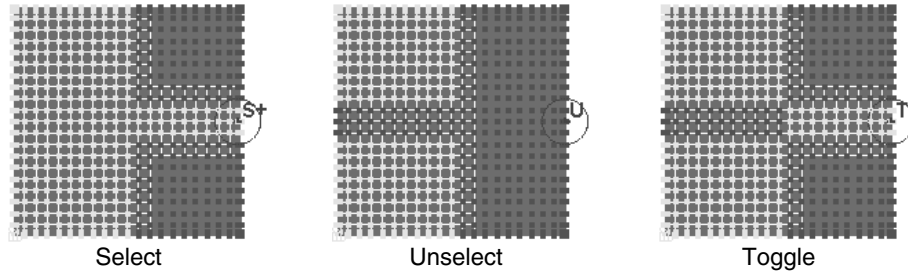

Tips

- To unselect selected components while Select is chosen, press the Ctrl (Windows, Linux, and IRIX) or Control (Mac OS X) key and paint over them. Similarly, when Unselect is chosen, press the Ctrl or Control key and paint to select unselected components.
- Press *u + left mouse button* and select the paint operation from the marking menu instead of the from the Tool Settings editor.

Add to Current Selection

By default, this option is turned on so that each stroke adds to the previous selection. This means you do not have to press the Shift key when you make a brush stroke to select, unselect, or toggle the selection of more components. If you want each stroke to override the previous one, turn Add to Current Selection off.

Select All

Selects all components on the selected surface(s).

Unselect All

Unselects all selected components on the selected surface(s).

Toggle All

Selects all unselected components and unselects all selected components on the selected surface(s).

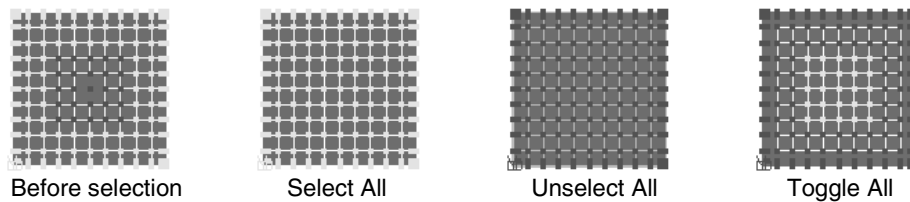

Create

Create > Sets > Quick Select Set

Creates a new “quick select set” from the current selection. The new selection set appears in the Edit > Quick Select Sets submenu.

You can edit the membership of an existing quick select set with the Relationship Editor.

Related topics

- ❖ “Save and reuse a selection” on page 49
- ❖ “Edit > Quick Select Sets” on page 53
- ❖ “Relationship Editor” on page 259

2 | Selecting

Reference > Create > Sets > Quick Select Set

3 Viewing the scene

How do I? View the scene and change the display

Move and rotate the camera

Tumble, track, dolly, or tilt the view

To look around in a scene, you move the virtual camera associated with a view panel.

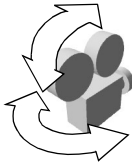
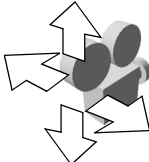
Hold	Drag	To...
Alt	The left mouse button	 Tumble
Alt	The middle mouse button	 Track

3 | Viewing the scene

How do I? > Tumble, track, dolly, or tilt the view

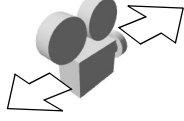
Hold	Drag	To...
Alt	The right mouse button or The left and middle mouse buttons	 Dolly
Alt + Ctrl	The left mouse button	Draw a box around the part of the view you want to dolly in on. <ul style="list-style-type: none">• If you drag the box out from left to right, you dolly in.• If you drag the box out from right to left, you dolly out.

These keyboard shortcuts actually correspond to tools. While it is much more convenient to use these keyboard shortcuts, you may occasionally want to use the tool form, or set the options for the tool:

- ❖ "View > Camera Tools > Tumble Tool" on page 80
- ❖ "View > Camera Tools > Track Tool" on page 81
- ❖ "View > Camera Tools > Dolly Tool" on page 82

To roll (tilt) the camera

- 1 In a view panel, choose View > Camera Tools > Roll Tool.
- 2 Drag the left mouse button to roll the camera.

To zoom the camera lens

- 1 In a view panel, choose View > Camera Tools > Zoom Tool.
- 2 Drag the left mouse button to zoom the camera lens.

Related topics

- ❖ "Use the mouse to control camera azimuth, elevation, yaw or pitch" on page 59
- ❖ "Return to previous views" on page 60
- ❖ "View > Camera Tools > Zoom Tool" on page 83
- ❖ "View > Camera Tools > Roll Tool" on page 83

How do I? > Use the mouse to control camera azimuth, elevation, yaw or pitch

Use the mouse to control camera azimuth, elevation, yaw or pitch

In a panel, choose...	holding the left mouse button ..
View > Camera Tools > Azimuth Elevation Tool	<ul style="list-style-type: none"> • Drag left and right to change the azimuth. • Drag up and down to change the elevation.
View > Camera Tools > Yaw Pitch Tool	<ul style="list-style-type: none"> • Drag left and right to change the yaw. • Drag up and down to change the pitch.
View > Camera Tools > Fly Tool	<ul style="list-style-type: none"> • Drag to change yaw and pitch. • Hold Ctrl and drag up and down to move forward and back.

Related topics

- ❖ "Tumble, track, dolly, or tilt the view" on page 57
- ❖ "Return to previous views" on page 60
- ❖ "View > Camera Tools > Azimuth Elevation Tool" on page 83
- ❖ "View > Camera Tools > Yaw Pitch Tool" on page 84
- ❖ "View > Camera Tools > Fly Tool" on page 85

Center the view on selected or all objects

To...	Do this
Show the selected objects	In the panel menus choose View > Frame selected or press F.
Show all objects	In the panel menus choose View > Frame all.
Point the camera at the selected objects but don't move the camera.	In the panel menus choose View > Look at selection.

Related topics

- ❖ "Return to previous views" on page 60

3 | Viewing the scene

How do I? > Return to previous views

- ❖ "Show or hide objects" on page 64

Return to previous views

To...	Do this
Go back in the view history.	In a panel, choose View > Previous or press [.
Go forward in the view history.	In a panel, choose View > Next or press].
Bookmark the current view.	In the panel menus choose View > Bookmarks > Edit bookmarks. Click New bookmark. Change the name of the bookmark to something descriptive.
Return to a bookmarked view.	In the panel menus choose View > Bookmarks and then click the name of the bookmark.
Create a shelf button for a bookmark	In the panel menus choose View > Bookmarks > Edit bookmarks. Click the bookmark. Click Add to shelf.

Related topics

- ❖ "Tumble, track, dolly, or tilt the view" on page 57
- ❖ "Center the view on selected or all objects" on page 59

Change and resize panels

Change the panel layout

You can set up the division of the main window into panels, adjust their size, and change the contents of panels between view and editors.

3 | Viewing the scene

How do I? > Change the panel layout

To...	Do this
Switch to a saved layout of panels.	<ul style="list-style-type: none">Click one of the Quick Layout buttons below the toolbox. or <ul style="list-style-type: none">In a panel, choose an item from the Panels > Saved Layouts submenu.
Change the number and division of panels	<ul style="list-style-type: none">Press the right mouse button on the panel contents proxy (at the bottom of the Quick Layout buttons below the toolbox) to show the layout menu. or <ul style="list-style-type: none">In a panel, choose an item from the Panels > Layouts submenu.
Resize the panels	Drag the dividers between panels. Drag the point where the dividers cross to resize all panels at the same time.
Switch between panel layout and filling the screen with the active panel.	Tap the space bar.
Set the contents of a panel.	<ul style="list-style-type: none">Click the icon for that panel in the layout proxy below the layout thumbnails, then choose a panel from the pop-up menu. or <ul style="list-style-type: none">In the panel, choose an item from the Panels > Panel submenu.
Use a preset layout of panels.	In a panel, choose an item from the Panels > Saved layouts menu.
Go back in the panel layout history.	In a panel, choose Panels > Layouts > Previous arrangement.
Go forward in the panel layout history.	In a panel, choose Panels > Layouts > Next arrangement.

3 | Viewing the scene

How do I? > Create a window from the contents of a panel (tear off)

Related topics

- ❖ "Control what camera is shown in a view" on page 62
- ❖ "Create a custom panel layout" on page 274
- ❖ "Quick layout buttons" on page 69
- ❖ "Panel editor" on page 93

Create a window from the contents of a panel (tear off)

To...	Do this
Copy a panel into a floating window.	In the panel, choose Panels > Tear Off Copy.
Move the contents of a panel into a floating window and change the panel's contents.	In the panel, choose Panels > Tear Off.

Control what camera is shown in a view

When you start a new scene it has four default cameras: persp (perspective), front, side, and top. You can assign a view panel to show the view through one of these camera, or create new cameras and assign them.

To...	Do this
Assign a camera to a view	In the panel, open the Panels menu and choose a camera from the Perspective or Orthographic submenu. or If the camera object is visible in the scene, select it and in the panel choose Panels > Look Through Selected.
Create a new camera for a view	In the panel, choose Panels > Perspective > New or Panels > Orthographic > New.

Show, hide, or change the grid

To...	Do this
Show or hide the grid in all view panels.	Choose Display > Grid.
Hide the grid in one panel.	In the panel, choose Show > Grid.
Edit the spacing, look, and extent of the grid.	Choose Display > Grid > □.

Related topics

- ❖ "Show information over top of a view (heads-up display)" on page 63
- ❖ "Display > Grid" on page 69
- ❖ "Show > Grid" on page 86

Show information over top of a view (heads-up display)

In the Display > Heads Up Display submenu, turn items on or off.

Related topics

- ❖ "Create a custom heads-up display readout" on page 291
- ❖ "Display > Heads Up Display" on page 71

Change the display of objects

Change the look and smoothness of the selected objects

Changing the *smoothness* affects how accurately Maya draws NURBS and subdivision surfaces on screen. It does not affect the actual geometry of the surface. Using a rougher display results in faster screen drawing for complex scenes.

You can also change whether Maya draws the object as a wireframe (only lines), with shading (showing the solid surfaces), or shaded with textures.

3 | Viewing the scene

How do I? > Show or hide objects

Press...	To display the selected objects as
1	Rough
2	Medium
3	Fine
	You can also use Display > NURBS Smoothness > Hull and Display > Subdiv Smoothness > Hull to get an even faster/rougher approximation of a NURBS or subdivision surface than the "Rough" option.
4	Wireframe
5	Shaded
6	Shaded with hardware-rendered textures
	You can also use X-ray shading, which automatically displays objects with slight transparency to let you see and select things behind opaque surfaces. In a view panel, select Shading > Shade Options > X-ray.

Related topics

- ❖ "Tumble, track, dolly, or tilt the view" on page 57
- ❖ "Show or hide objects" on page 64
- ❖ "Change an object's wireframe color" on page 68

Show or hide objects

To...	Do this
Hide the selected objects.	Choose Display > Hide > Hide Selection.
Redisplay the last object(s) you hid.	Choose Display > Show > Show Last Hidden.
Show all hidden objects.	Choose Display > Show > All.

3 | Viewing the scene

How do I? > Show or hide components

To...	Do this
Hide or show all objects of a specific type.	<ul style="list-style-type: none">• To change the display of all panels, use the items in the Display > Hide and Display > Show sub-menus.• To change the display of one panel, use the items in the panel's Show menu.
Show a specific hidden object.	Select the object's node in one of the editors and choose Display > Show > Show Selection.
Select a hidden object.	Use the Outliner or Hypergraph to select the object's node.
Hide the actual geometry of an object while leaving other components visible.	Choose Display > Object Display > No Geometry.
Show only an object's bounding box.	Choose Display > Object Display > Bounding Box.

Related topics

- ❖ "Show or hide components" on page 65
- ❖ "Show or hide object-specific UI" on page 66
- ❖ "Show an isolated subset of objects or components in a panel" on page 67

Show or hide components

Use the items in the Display > NURBS Components, Display > Polygon Components, and Display > Subdiv Surface Components submenus, as well as the Display > Hide and Display > Show menus submenus.

Tip When you are in component selection mode, Maya automatically shows the components on the selected objects.

3 | Viewing the scene

How do I? > Show or hide object-specific UI

To...	Do this
Show or hide geometry components on the selected objects.	Use the Display > NURBS Components, Display > Polygon Components, and Display > Subdiv Surface Components submenus.
Show CVs on all NURBS surfaces.	Choose Display > Show > All Surface CVs.
Show or hide backfaces (polygon faces hidden behind other faces) on the selected polygons.	Choose Display > Component Display > Backfaces.

Related topics

❖ "Show or hide objects" on page 64

Show or hide object-specific UI

To show or hide...	Do this
A lattice deformer attached to the selected object.	Choose Display > Component Display > Lattice Points to show or hide the control points on the lattice. Choose Display > Component Display > Lattice Shape to show or hide the lattice object.
Pivot points on the selected objects.	Choose Display > Component Display > Rotate Pivots or Display > Component Display > Scale Pivots.
Selection handles attached to the selected objects.	Choose Display > Component Display > Selection Handles.
Manipulators on the selected cameras or lights.	Use the Display > Camera/Light Manipulator submenu.

How do I? > Show an isolated subset of objects or components in a panel

Related topics

❖ "Show or hide objects" on page 64

Show an isolated subset of objects or components in a panel

Use the Isolate Select feature (Show > Isolate Select > View Selected) to show only certain objects or components in a view panel.

Unlike the Display > Hide commands, the Isolate Select feature can also isolate components (polygon faces, NURBS CVs, or subdivision surface mesh faces), and only affects the display, not rendering.

Each panel maintains its own Isolate Select settings.

To...	Do this
Only show the selected objects/components in a panel.	In the panel, choose Show > Isolate Select > View Selected.
Always only show the selected objects in the panel as the selection changes.	In the panel, turn on Show > Isolate Select > Auto Load Selected Objects.
Choose whether new objects will or won't be in the isolated subset.	In the panel, turn Show > Isolate Select > Auto Load New Objects on or off.
Add or remove objects in the isolated subset when Auto Load is off.	In the panel: <ul style="list-style-type: none"> • To change the isolated subset to the current selection, choose Show > Isolate Select > Load Selected Objects. • To add the current selection to the isolated subset, choose Show > Isolate Select > Add Selected Objects. • To remove the current selection from the isolated subset, choose Show > Isolate Select > Remove Selected Objects.

3 | Viewing the scene

How do I? > Change an object's wireframe color

To...	Do this
Save and reuse isolation settings.	In the panel: <ul style="list-style-type: none">To save the current isolation settings, choose Show > Isolate Select > Bookmarks > Bookmark Current Objects.To recall an isolated subset, choose it from the Show > Isolate Select > Bookmarks submenu.

Related topics

- ❖ "Show or hide objects" on page 64

Change an object's wireframe color

You can assign different wireframe colors to objects to make them easier to keep track of in the view panels.

To...	Do this
Change an object's wireframe color.	Select the object(s) and choose Display > Wireframe Color.
Change the colors available in the wireframe color palette.	Choose Display > Wireframe Color and double-click a color swatch. or Choose Window > Settings/Preferences > Colors. On the General tab, open the User Defined section.
Make an object use the default wireframe color.	Select the object(s) and choose Display > Wireframe Color, then click Default.

Related topics

- ❖ "Change the look and smoothness of the selected objects" on page 63
- ❖ "Change user interface colors" on page 273

Reference Tools

Quick layout buttons

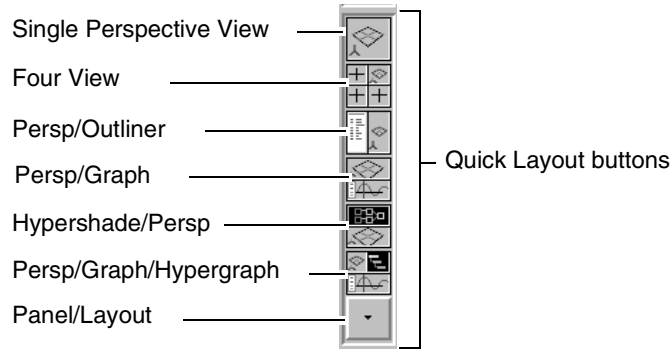

The quick layout buttons let you switch to one of a few common panel layouts quickly.

- Click one of the layout thumbnails to switch to the pictured layout and panels.
- Press the right mouse button on one of the layout thumbnails to change the layout/panels the button loads.
- Press the left mouse button on a box in the layout thumbnail at the bottom to change the content of a panel in the current layout.
- Press the right mouse button on the layout thumbnail to change the current layout.

Related topics

- ❖ "Change the panel layout" on page 60
- ❖ "Create a custom panel layout" on page 274
- ❖ "Panel editor" on page 93

Menus

Display

Display > Grid

Shows or hides the grid in all view panels.

When the grid is visible, you can turn it off in an individual panel using the panel's Show > Grid item.

3 | Viewing the scene

Reference > Display > Grid

Related topics

- ❖ "Show, hide, or change the grid" on page 63
- ❖ "Show > Grid" on page 86

Display > Grid >

Size

You can change the size and length of the grid, set the number of subdivision lines, and the increment for the grid lines.

Length and Width

Sets the number of units for the length and width of the grid. The default is 12 units.

Grid Lines Every

Displays a grid line every n units. The default is 5.

Subdivisions

Specifies the number of divisions between major grid lines. Setting the Subdivisions option to a value greater than 1 specifies that each main grid interval is subdivided by the amount specified. The default is 5.

Color

You can change the color of the axes, grid lines and labels, and subdivision lines.

Axes

Specifies a color for the X and Z axes on the grid. The default is dark grey.

Grid Lines & Numbers

Specifies a color for the grid lines and the grid line numbers. The default is light grey.

Subdivision Lines

Specifies a color for the subdivision lines. The default is light grey.

Note You can also change the color of the axes, grid lines and numbers, and subdivision lines in the Colors window (Window > Settings/Preferences > Colors). Go to the Inactive tab and then the Modeling category to find these color options. Here you can also change the color of the X-, Y-, and Z-axis that appear in the Origin and View axes.

Display

You can turn on and off the display of grid elements, including axes, thicker lines for axes, grid lines, subdivision lines, and grid line numbers.

Axes

Turns on or off the display of the axes. The default is on.

Thicker Line for Axes

Turns on or off the display of thicker lines for the axes. The default is on.

Grid Lines

Turns on or off the display of the grid lines. The default is on.

Subdivision Lines

Turns on or off the display of the subdivision lines. The default is on.

Perspective Grid Numbers

In the Perspective view, you can set the grid line numbers to display on the axes, along the edge of the grid, or just hide them.

Orthographic Grid Numbers

In the Orthographic views (top, side, front), you can set the grid line numbers to display on the axes, along the edge of the grid, or just hide them.

Hide	Hides the grid line numbers. This is the default for both Perspective and Orthographic Grid Numbers.
On Axes	Displays the grid line numbers along the axes.
Along Edge	Displays the grid line numbers along the edge of the grid.

Note To restore the default grid option settings, select Edit, Reset Settings in the Grid Options window. However, this does not restore the default grid color settings. To restore the default colors, go to the Colors window (Window > Settings/Preferences > Colors) and select Edit, Reset to Defaults. This restores all color defaults, including the grid colors.

Display > Heads Up Display

This submenu contains a number of readouts you can show or hide over top of the view panel content.

3 | Viewing the scene

Reference > Display > Heads Up Display

Related topics

- ❖ "Show information over top of a view (heads-up display)" on page 63
- ❖ "Create a custom heads-up display readout" on page 291

Items

Object Details

Displays a list of object details that includes: Backfaces, Smoothness, Instance, Display Layer, Distance From Camera and number of Selected Objects. The details are displayed in the top-right corner of the panel. The default is off.

Poly Count

Displays polygon statistics for the visible objects displayed in the view panel, including Vertices, Edges, Faces, Triangles, and UVs. This feature is useful for games development. The first column on the left lists the total components of all the polygons in the scene. The second column lists the total components of the selected polygon(s). The third column lists the total selected components. The default is off.

Animation Details

Turns on or off the display of a list of animation details, which include: Playback Speed, Current Character, and IK Solver Enable. The details are displayed above the Frame Rate in the bottom-right corner of the panel. The default is off.

Camera Names

Displays the camera name (persp, top, side, front) in the bottom-center of camera views. The default is on.

Frame Rate

Displays the frame rate in Hertz (fps) for the current port in the bottom-right corner. The default is off.

View Axis

Displays the global axis in the bottom-left corner of all views. The default is on.

Origin Axis

Displays the global axis at the origin (0, 0, 0) within the perspective view. The default is on.

3 | Viewing the scene

Reference > Display > Hide, Show

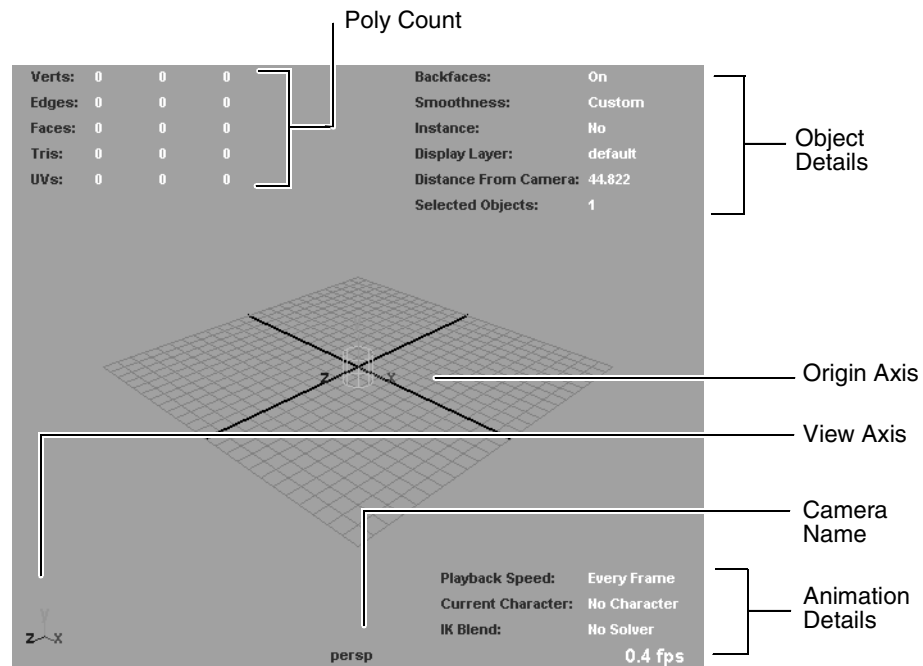

Display > Hide, Show

Use Display > Hide to hide items you aren't working on and reduce visual clutter. This is handy if you want to remove an object from the view, but do not want to delete it or move it.

To redisplay items, use the Display > Show submenu, which includes the same selections as Display > Hide.

Related topics

❖ "Show or hide objects" on page 64

The Hide menu items are:

Items

Hide Selection

Hides selected object(s).

Hide Unselected Objects

Hides all unselected objects.

3 | Viewing the scene

Reference > Display > Hide, Show

Hide Unselected CVs

To control the display of CVs, select the CVs that you want to remain visible, and then use Display > Hide > Hide Unselected CVs to hide all the other CVs on that surface. This affects the display of CVs in component selection mode, as well as CVs displayed in object selection mode by the use of Display > NURBS Components > CVs.

Tip It is possible to use selective CV display on more than one surface at a time.

The selective CV display function operates exclusively from other Maya Hide and Show commands, and therefore menu selections such as Display > Show > All and others do not effect CVs whose display has been set using selective CV display.

All

Hides all objects, whether they are selected or not.

Hide Geometry

Displays a menu that lets you select the type of geometry you want to hide.

Hide Kinematics

Displays a menu that lets you select the type of kinematics you want to hide.

Hide Deformers

Displays a menu that lets you select the type of deformers you want to hide.

Hide Cloth

Available only if you have Maya Unlimited and are using Maya Cloth. Hides cloth objects. For details, see Cloth.

Lights

Hides lights.

Cameras

Hides cameras.

Texture Placements

Hides texture placements.

Construction planes

Hides construction planes.

Animation Markers

Hides animation markers.

Light Manipulators

Hides light manipulators.

Camera Manipulators

Hides camera manipulators.

Display > Wireframe Color

Lets you set the wireframe color of the selected objects. You can leave the color selection window open and keep selecting and applying colors.



Display > Object Display

The items in this submenu control the display and selectability of the selected objects.

- Bounding box draws a box around the total space occupied by each object.
- Geometry shows or hides the actual geometry of the object (for example, the surface or polygon mesh). This lets you turn on the display of components (such as CVs) but turn off the actual object itself.

Related topics

- ❖ "Change the look and smoothness of the selected objects" on page 63
- ❖ "Show or hide objects" on page 64

Display > Component Display

The items in this submenu let you show or hide object-specific UI in the view windows.

3 | Viewing the scene

Reference > Display > Component Display

Related topics

- ❖ "Show or hide components" on page 65
- ❖ "Show or hide object-specific UI" on page 66

Items

Backfaces

If you selected a polygonal object, turns on or off the display of the object's backfaces.

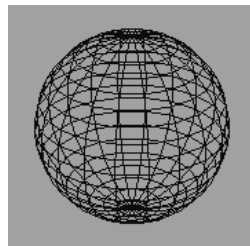

Backfaces

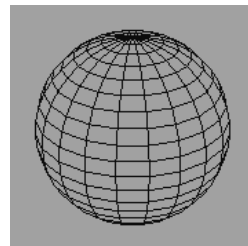

No backfaces

Lattice Points

If you selected a lattice deformer (an L icon represents a lattice deformer handle), turns on or off the display of the lattice points. For information on lattices, see Character Setup.

Lattice Shape

If you selected a lattice deformer, turns on or off the display of the object's lattice shape. The lattice deformer switches between displaying its lattices and the L icon. For information on lattices, see Character Setup.

Local Rotation Axes

Turns on or off the display of the object's local rotation axes.

Joint Labels

Turns on or off the display of joint labels in the scene view for selected joints.

Rotate Pivots

Turns on or off the display of the object's rotate pivots.

Scale Pivots

Turns on or off the display of the object's scale pivots.

Selection Handles

Turns on or off the display of selection handles on manipulators.

Display > Camera/Light Manipulator

Camera items

Center of Interest

Turns on or off the display of the camera's center of interest manipulator.

Pivot

Turns on or off the display of the camera's pivot.

Clipping Planes

Turns on or off the display of the camera's clipping planes.

Cycling Index

Turns on or off the display of the camera's cycling index. By clicking on this control, you can cycle through the available manipulator controls one at a time for the selected camera.

Light items

Center of Interest

Turns on or off the display of a light's center of interest manipulator.

Pivot

Turns on or off the display of a light's pivot.

Cone Angle

Turns on or off the display of a light's cone angle.

Penumbra

Turns on or off the display of a light's Penumbra.

Look Through Barn Doors

Barn doors are doors or shutters fitted on the spotlight, which let you create a square spot effect. Shows the view through the spotlight's barn doors. These manipulators appear when you are in Render View or are looking through the selected light (Panels > Look Through Selected).

Decay Regions

Turns on or off the display of a light's decay regions.

3 | Viewing the scene

Reference > Window > Frame All in All Views, Frame Selection in All Views

Cycling Index

Turns on or off the display of the light's cycling index. By clicking on this control, you can cycle through the available manipulator controls for the selected light one at a time.

For more information about creating lights and editing light attributes, see [Rendering](#).

Window

Window > Frame All in All Views, Frame Selection in All Views

Tracks and dollies *all* view panels to show all objects or the selected objects.

To show all objects or the selected objects in a specific view panel, use the panel's View menu.

Related topics

❖ ["Center the view on selected or all objects"](#) on page 59

Panel menus

View > Camera Settings

Perspective

Turn Perspective on so that the camera uses a perspective view. This means that the lines converge at infinity. If turned off, the camera uses an orthographic view.

Journal

Turn Journal on to copy camera view actions, such as tumble, track, and zoom, to the MEL journal making the commands undoable. Normally, the camera command view actions are not copied to the MEL journal and they are not undoable. For more information on the MEL journal, see [MEL](#).

No Gate

Displays no frustrum. This is the default.

3 | Viewing the scene

Reference > View > Camera Settings

Film Gate

Displays the viewable frustum according to the film back size. The aspect ratio of the window (or rendering resolution) determines what you actually see. Also sets the camera Overscan attribute to 1.5. The following illustration shows the film gate representing the maximum viewable (or renderable) area.

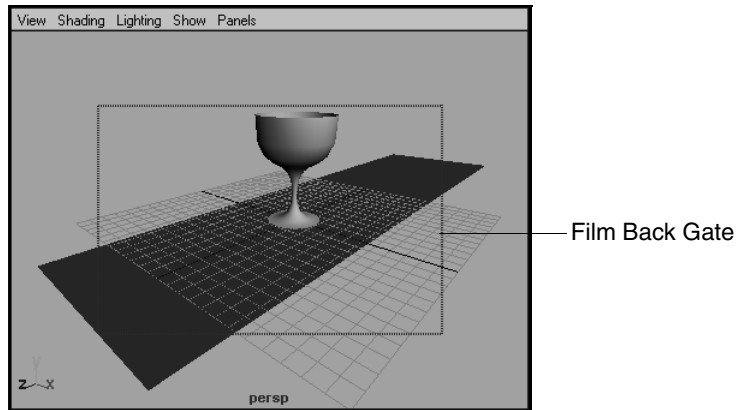

Resolution Gate

Displays the renderable frustum for the current resolution specified in Render Globals. This often specifies a more exact rendered image than the Film Gate option. Also sets the camera Overscan attribute to 2.0.

Note If the aspect ratio between the film back and the resolution is the same, then the two resulting rendered images match.

Field Chart

Turn Field Chart on to display a grid that represents the twelve standard cell animation field sizes. The largest field size (number 12) is identical to the rendering resolution (the resolution gate). Render Resolution must be set to NTSC dimensions for this option to have meaning.

Safe Action

Turn this option on to display a box defining the region that you should keep all of your scene's action within if you plan to display the rendered images on a television screen. The safe action view guide represents 90% of the rendered resolution (the resolution gate). Render Resolution must be set to NTSC dimensions for this option to have meaning.

3 | Viewing the scene

Reference > View > Camera Tools > Tumble Tool

Safe Title

Turn this option on to display a box defining region that you should keep titles (text) within if you plan to display the rendered images on a television screen. The safe title region represents 80% of the rendered resolution (the resolution gate). Render Resolution must be set to NTSC dimensions for this option to have meaning.

Fill

Automatically selects a horizontal or vertical fit so that the selected image fills the render frame.

Horizontal

Selects a horizontal fit for the selected image in the render frame.

Vertical

Selects a vertical fit for the selected image in the render frame.

Overscan

Selects a slightly larger fit for the selected image in the render frame.

View > Camera Tools > Tumble Tool

Revolves the camera by varying the azimuth and elevation angles in a perspective view. You can also press alt + the left mouse button. Hold Shift to constrain the camera movement.

Related topics

❖ *"Tumble, track, dolly, or tilt the view"* on page 57

View > Camera Tools > Tumble Tool >

Tumble scale

Scales the speed of the camera movement. The slider range is 0.01 to 10. The default value is 1.

Tumble camera about

Center of Interest

The camera tumbles about its center of interest. Tumble camera about is set to Center of interest by default.

Tumble Pivot

The camera tumbles about its pivot point. This tumble pivot can also be set in the camera's Attribute Editor. These values are stored in world space coordinates.

3 | Viewing the scene

Reference > View > Camera Tools > Track Tool

View operations such as Frame Selection, Frame All, Look at Selection, Default Home, and Bookmarks all set the tumble pivot.

Orthographic views

Locked

If on, you cannot tumble an orthographic camera. If off, you can tumble an orthographic camera. Locked is on by default.

Stepped

If on, you can tumble an orthographic camera in discrete steps. The Stepped operation lets you easily return to the Default Home positions. If off, you can tumble an orthographic camera smoothly. Stepped is only available if Locked is off. Stepped is on by default.

Ortho step

The angle of steps (in degrees) that you can tumble an orthographic camera when Locked is off and Stepped is on. The valid range is 0.01 to 180. The default value is 5.

View > Camera Tools > Track Tool

Tracks the camera vertically and horizontally. You can also press alt + the middle mouse button. Hold Shift to constrain the camera movement.

Related topics

- ❖ "Tumble, track, dolly, or tilt the view" on page 57

View > Camera Tools > Track Tool >

Track Geometry

If off, as the camera moves an object moves at a speed that may be different than the speed of the cursor. This problem occurs with objects far from the camera. Track Geometry is off by default.

If on, as the camera moves, an object moves at the same speed as the cursor. The object selected at the beginning of the Track operation remains under the cursor. Tracking is slower (especially if there are many objects in the scene) if Track Geometry is on.

Track Scale

Scales the speed of the camera movement. The slider range is 0 to 100. The default value is 1.

3 | Viewing the scene

Reference > View > Camera Tools > Dolly Tool

View > Camera Tools > Dolly Tool

Tracks the camera forward and backward. You can also press alt + the right mouse button (or alt + the left and middle mouse buttons). Use Ctrl + Alt + the left mouse button to drag a marquee around the area you want to dolly in on.

Related topics

❖ "Tumble, track, dolly, or tilt the view" on page 57

View > Camera Tools > Dolly Tool >

Scale

Scales the speed of the camera movement. The slider range is 0.01 to 10. The default value is 1.

Dolly

Local

If on, drag in the camera's view to move the camera toward or away from its center of interest. If off, drag in the camera's view to move both the camera and its center of interest along the camera's sight line. Local is on by default.

Center of Interest

If Center of Interest is on, MMB-drag in the camera's view to move the camera's center of interest toward or away from the camera. If off, drag in the camera's view to move the camera toward or away from its center of interest. LMB-marquee a region and snap the center of interest to the center of those objects. Center of Interest is off by default.

If Center of Interest (and/or Local) and Bounding box are on, when you drag in the views, a red line with a small x at the end points to indicate the Center of Interest.

Snap box dolly to

A box dolly moves the center of interest to the marquee region when you use the Ctrl-Alt-drag (Windows, Linux, and IRIX) or Control-Option-drag (Mac OS X) method to dolly the camera.

Surface

If on, when you perform a box dolly (Ctrl-drag or Control-drag) on an object, the center of interest moves onto the surface of the object. Calculating the surface point is slower if Smooth Shade mode is off (and especially if there are many visible objects in the scene).

Bounding box

If on, when you perform a box dolly (Ctrl-drag or Control-drag) on an object, the center of interest moves to the center of the object's bounding box. Bounding Box is on by default.

View > Camera Tools > Zoom Tool

Changes the focal length on a camera. Zooming in is like using a telephoto lens. Zooming out is like using a wider angle lens.

You can use zoom in both a perspective or orthographic view.

To move in or out without changing the viewing angle, use Dolly.

Related topics

- ❖ "Tumble, track, dolly, or tilt the view" on page 57
- ❖ "Use the mouse to control camera azimuth, elevation, yaw or pitch" on page 59

View > Camera Tools > Zoom Tool >

Zoom Scale

Scales the speed of the camera movement. The slider range is 0.01 to 3. The default value is 1.

View > Camera Tools > Roll Tool

Rotates the display around its horizontal axis.

Related topics

- ❖ "Tumble, track, dolly, or tilt the view" on page 57
- ❖ "Use the mouse to control camera azimuth, elevation, yaw or pitch" on page 59

View > Camera Tools > Roll Tool >

Roll Scale

Scales the speed of the camera movement. The slider range is 0.01 to 10. The default value is 1.

View > Camera Tools > Azimuth Elevation Tool

Revolves the camera about the center of interest in the perspective view.

3 | Viewing the scene

Reference > View > Camera Tools > Yaw Pitch Tool

The angle of a camera's sight line relative to the ground plane is also referred to as its *elevation*; the angle of a camera's sight line relative to a plane perpendicular to the ground plane is also referred to as its *azimuth*.

Related topics

- ❖ "Tumble, track, dolly, or tilt the view" on page 57
- ❖ "Use the mouse to control camera azimuth, elevation, yaw or pitch" on page 59

View > Camera Tools > Azimuth Elevation Tool > □

Scale

Scales the speed of the camera movement. The slider range is 0.01 to 10. The default value is 1.

Rotation type

Controls whether the camera movement is an Azimuth Elevation movement or a Yaw Pitch movement.

Tip Press Shift to constrain the camera's movement.

View > Camera Tools > Yaw Pitch Tool

Tilting a camera means rotating the camera up or down; panning a camera means rotating the camera left or right. The scene in the camera's view moves in the opposite direction.

The angle of rotation up or down is also referred to as *pitch*; the angle of rotation left or right is also referred to as *yaw*.

Related topics

- ❖ "Tumble, track, dolly, or tilt the view" on page 57
- ❖ "Use the mouse to control camera azimuth, elevation, yaw or pitch" on page 59

View > Camera Tools > Yaw Pitch Tool > □

Scale

Scales the speed of the camera movement. The slider range is 0.01 to 10. The default value is 1.

Rotation type

Controls whether the camera movement is a Yaw Pitch movement or an Azimuth Elevation movement.

Tip Press Shift to constrain the camera's movement.

View > Camera Tools > Fly Tool

Lets you navigate your scene as if you were playing a 3D first-person perspective game. The camera flies through your scene without being constrained by any geometry.

- Hold Ctrl and drag up to fly forward or down to fly backward.
- To change the camera direction, release the Ctrl or Control key and drag the left mouse button.
- Tumble, track, and dolly are available while the Fly Tool is active.

Show menu

Use the items in this menu to show or hide specific object types in a panel.

Related topics

- ❖ "Show or hide objects" on page 64

Show > Isolate Select

Lets you limit a panel to show only an isolated subset of all objects in the scene.

Related topics

- ❖ "Show an isolated subset of objects or components in a panel" on page 67

Items

View Selected

Activates or deactivates the isolate select feature. When activated, the word "Isolate" appears at the bottom of the panel and the current selection becomes isolated.

3 | Viewing the scene

Reference > Show > Grid

Auto Load New, Selected Objects

Turn on to automatically update the isolate select panel when you add new objects or change your selection. If turned off, you must use the Load, Add, or Remove Selected Objects options to update the panel.

Load, Add, Remove Selected Objects

If you don't have auto load on, you can use these options to control the isolate select display. Select items from the isolate panel or another panel and then load, add, or remove them as needed. Note that Load Selected Objects replaces the display with the current selection, while Add Selected Objects adds the current selection to the selections already displaying.

Bookmarks

Enables you to bookmark an isolated selection. To create a bookmark, choose Show > Isolate Select > Bookmarks > Bookmark Current Objects. Choose the option box if you want to name the bookmark; otherwise, a default name is used.

To view bookmarked items, choose Show > Isolate Select > Bookmarks > *BookmarkName*. Choose it again to turn it off and return to the previous view. You can view multiple bookmarks at the same time.

Bookmarks are saved with the scene as a set.

Show > Grid

Allows you to turn the grid off in a single panel.

Related topics

- ❖ "Show, hide, or change the grid" on page 63
- ❖ "Display > Grid" on page 69

Shading menu

The Shading menu provides a number of ways to look at your scene. The quality can range from a simple wireframe display to a smooth- shaded view.

Related topics

- ❖ "Change the look and smoothness of the selected objects" on page 63

Wireframe

Draws edges for polygon meshes and isoparametric curves for surfaces. This is the default shading quality.

Smooth Shade All

Displays all surfaces, meshes, and particles as smooth-shaded objects.

Smooth Shade Selected Items

Displays selected items as smooth-shaded objects.

Flat Shade All

Displays all surfaces and meshes as flat-shaded objects.

Flat Shade Selected Items

Displays selected items as flat-shaded objects.

Bounding Box

Shows objects as boxes that represent their bounding volumes. Bounding boxes speed up Maya operations and can make a significant difference for complex models.

The bounding box encompasses the hulls as well as the actual geometry. As a result, the bounding box may have dimensions larger than those of the geometry.

Note To see bounding box coordinates, open the Attribute Editor, click on the shape node tab, and open the Object Display section. It shows the read-only minimum and maximum world space boundary coordinates of a surface along the X, Y, and Z axes.

Points

Shows objects as groupings of individual points.

Shade Options

There are three display options for shaded objects.

Wireframe on Shaded

Superimposes a wireframe display on all shaded objects in a view.

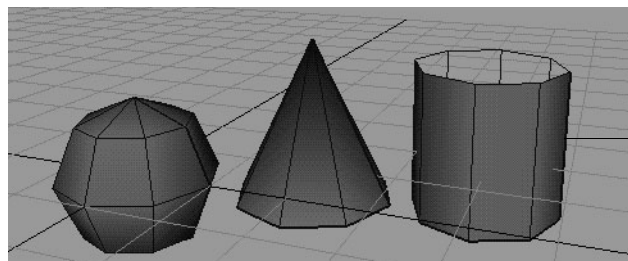

Wireframe isoparms appear over the shaded objects

3 | Viewing the scene

Reference > Shading menu

X-Ray	Displays all shaded objects as semi-transparent. This can be useful for seeing hidden parts of a model.
Transparency Sorting	Draws transparent objects in order corresponding to their distance from the camera. This is not equivalent to transparency sorting in high-quality rendering.

Interactive Shading

Controls the display of objects during interactive modes (such as transformations, camera navigation, and playbacks). At the same time the normal display can be in some sort of shaded mode. For example, the normal display can be smooth-shaded while the interactive display is bounding box. There are four interactive shading options:

High Quality Rendering	There are several sub-options for the high-quality rendering setting. You can choose from:
Shaded	
Wireframe	Displays objects in wireframe mode during the interactive mode.
Bounding Box	Displays objects as bounding boxes during the interactive mode.
Points	Displays objects as points during the interactive mode.

Color Index Mode

On Linux and IRIX only, lets you manipulate a wireframe object in a complex scene more quickly (for example, if you are using a full-color image plane while working in wireframe mode).

Backface Culling

For objects displayed in smooth shade or flat shade mode, makes the object's back face transparent which helps speed the display or manipulation of objects.

Smooth Wireframe

Displays smooth wireframed objects in Maya's 3D views, including the Hardware Render Buffer and the 3D Paint Effects view.

Note Does not work in 2D views, including the UV Texture Editor.

Hardware Texturing

Displays Maya's hardware textured rendered results as if they were being displayed in an external viewer. (See also the Rendering book in the Maya documentation set.)

Hardware Fog

Simulates hardware fog effects achievable in programs outside of Maya. Displays how a spotlight's fog is distributed before you render. Used for preview purposes, Hardware Fog only displays in the perspective view. (See also the Rendering book in the Maya documentation set.)

Apply Current to All

Applies the current 3D view's shading style to all objects in the scene.

Lighting menu

Use the items in this menu to select which lights or groups of lights to use in your scene.

Related topics

- ❖ "Change the look and smoothness of the selected objects" on page 63

Items

Use Default Lighting

Lights the scene using only a single point light situated at the camera.

Use All Lights

Uses all lights in the scene, to a maximum of eight lights. This option gives you a representation of what the lights look like when the image is rendered.

Note This option does not include the default light.
If there are no lights in the scene, the scene renders as an all black image.

Use Selected Lights

Uses only selected lights. If you change the light selection, the lighting also changes respectively.

3 | Viewing the scene

Reference > Panels menu

Use Previously Specified Lights

Select this option to use the lights selected with the Specify Selected Lights option. This option is grayed until you choose Specify Selected Lights. If you select a different set of lights when this option is selected, the scene still uses the previously selected lights.

Note This menu item can be turned off by picking any of the items above it.

Two Sided Lighting

Turn this option on to illuminate both sides of an object. Note that Maya's performance may decrease on some systems.

Shadows

This menu item is only available on cards with Transform and Lighting capabilities. Display hardware shadow maps from directional and spot lights for geometry (NURBS, polygons, subdivision surfaces) and particles (points, multipoints, and spheres only). These hardware shadow maps can be calculated and displayed on graphics cards with drivers that support the ARB_multitexture and EXT_texture_env_combine OpenGL extensions (such as graphics cards with NVidia GeForce or Quadro GPU, or ATI Radeon 8800). See the Rendering guide for details on how to preview hardware shadow maps.

Specify Selected Lights

Lets you use a preset selection of lights. Select the lights you want to use then select Specify Selected Lights. Once specified, turn on Lighting > Use Previously Specified Lights to use this light selection. Unlike Use Selected Lights, if you change the light selection, the scene will still use the previously selected lights. For additional information on lighting, see Rendering.

Panels menu

The items in this menu let you set the contents of this specific panel as well as the overall layout and panel contents.

Related topics

- ❖ "Change the panel layout" on page 60
- ❖ "Control what camera is shown in a view" on page 62

- ❖ "Create a custom panel layout" on page 274
- ❖ "Quick layout buttons" on page 69
- ❖ "Panel editor" on page 93

Items

Perspective

Lets you change to a perspective view or create a new perspective view.

Orthographic

Lets you change to an orthographic view or create a new orthographic view.

Look Through Selected

Lets you look through a selected camera, object, or light.

Panel

Displays a menu containg the following:

Outliner	Opens the Outliner, where you can view objects and their attributes hierarchically.
Graph Editor	Opens the Graph Editor where you can edit visual representations of keys and animation curves (keysets). For more information, see Animation.
Dope Sheet	Opens the Dope Sheet, where you can edit event and sound synchronization and timing. For more information, see Animation.
Trax Editor	Opens the Trax Editor, where you can create and edit time-independent clips of character animation. For more information, see Animation.
Hypergraph	Opens the Hypergraph, which gives you an overview of your entire scene, all objects it contains, and the relationships between those objects.
Hypershade	Opens the Hypershade, which you can use to create and edit rendering nodes, and to view and edit rendering (or shading) networks. For more information, see Rendering.
Visor	Opens the Visor, which you can use to show images of shading nodes you can create, those already in your scene, and those in online libraries, in a visual outline form. For more information, see Rendering.

3 | Viewing the scene

Reference > Panels menu

UV Texture Editor	Opens the UV Texture Editor window, which you use to map textures to a polygonal model. For more information, see Polygonal Modeling.
Render View	Opens the Render View window, where you can test render single frames and interactively tune rendering attributes. For more information, see Rendering.
Blend Shape	Lets you create character deformations. For more information, see Character Setup.
Dynamic Relationships	Lets you view or edit connections between dynamics elements such as particle emitters, collisions, etc. For more information, see Dynamics.
Devices	Lets you use external tools and plug-ins for special devices, such as Motion Capture.
Relationship Editor	Opens the Relationship Editor, which you can use to group and manipulate objects as sets and assign shading groups to geometry.
Reference Editor	Opens the Reference Editor, which you can use to specify settings for importing files by reference.
Component Editor	Opens the Component Editor, which you can use to edit data assigned to components.
Paint Effects	Opens the Paint Effects Panel, where you can interactively render strokes without rendering the rest of the scene. New strokes render as you paint them in this view. For more information, see Painting.

Layouts

Lets you specify how different camera views are arranged spatially in the Maya window.

Saved Layouts

Lets you select a panel layout.

Tear Off

Moves the current camera view into a separate window. The current view is replaced with the next view in the Panels list (to see this list, select Panels > Panel Editor).

Tear Off Copy

Copies the current camera view into a separate window.

Panel Editor

Opens the Panel editor window, where you can create new panels, re-label existing panels, rename layouts, and change layout configurations.

Windows and editors

Panel editor

To show the panel editor, choose Panels > Panel Editor in a panel

Tabs

Panels

Displays existing panels you can rename or delete.

- Select a panel and edit the Label field to rename it. You cannot rename the Top, Side, Front, or Persp view panels.
- Select a panel and click Delete to remove it from the list.

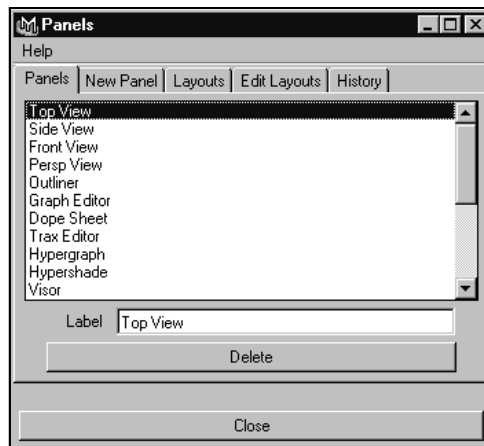

New Panel

Contains controls for creating a new panel type.

- ❖ “Add a new panel to the list of available panels” on page 275

3 | Viewing the scene

Reference > Panel editor

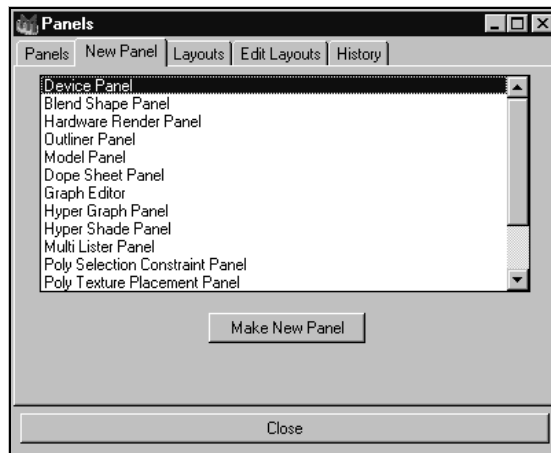

Layouts

Displays existing panel layouts.

- Click New Layout to add an item to the list.
- Click a layout and click the Edit Layouts tab to edit it.
- To delete a layout, click it in the list, then click Delete.

Edit Layouts

Displays the current panel layout for editing.

- ❖ “Create a custom panel layout” on page 274

Configurations

Use this tab to change the configuration and proportions of the layout.

From the pull-down menu, select the panel layout you want.

Resize the panes by dragging the borders in the thumbnail view of the layout. The main window changes to reflect your changes.

3 | Viewing the scene

Reference > Panel editor

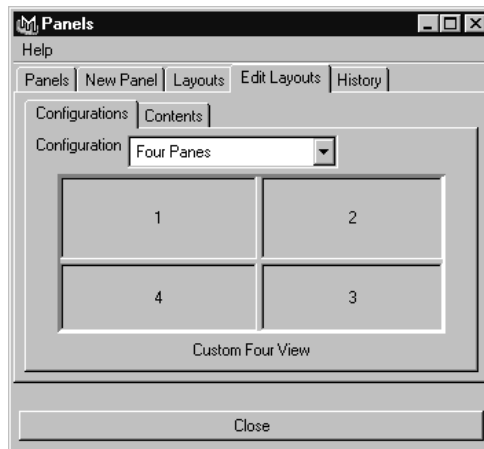

Contents

Use this tab to change which panel contents appear in the layout.

Scene

Independent

Scene independent layouts are available for all scenes. Their contents are defined by panel types.

If you have multiple panels of the same type in a scene, it is not certain which panels show up when you select your layout. This is not a problem in most cases; however, if you are working in a particular scene a great deal, then develop layouts that you can save specifically with that scene.

Associated with Scene

These layouts are only usable with the current scene. You can specify a particular panel if you have more than one of the same type.

3 | Viewing the scene

Reference > Panel editor

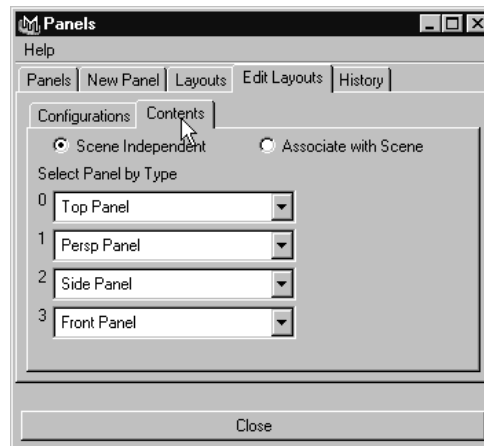

History

Displays the history of the panels you used.

Maya keeps a record of panel layout changes. This lets you step forward or back through each view. This is helpful if you are moving between two layouts and cannot remember their names.

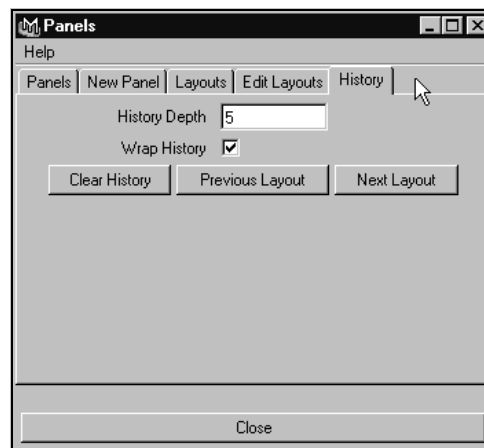

History Depth

Specify the number of configurations you want stored in the history.

Wrap History

Toggle this on to return you to the first view or the most recent view configuration when you reach the end of recorded history.

Clear History

Click this button to delete the record of all the panels you have used.

Previous Layout

Click this button to browse back through the panel layouts.

Next Layout

Click this button to browse forward through the panel layouts.

Nodes

Camera node

Auto Render Clip Plane

If on, Maya automatically sets the near and far clipping planes so they enclose all objects within the camera's view. All objects render and depth precision problems are eliminated. Clipping planes are only available to the software renderer (not visible in the views).

If off, the near and far clipping planes are set to the Near Clip Plane and Far Clip Plane values. Auto Render Clip Plane is on by default.

In some cases you should turn off Auto Render Clip Plane:

- to ensure frames rendered from previous versions of Maya exactly match frames rendered from Maya 4.5
- to limit which objects render based on their distance from the camera

Film Back

The Film Back attributes control the basic properties of a camera (for example, the camera's film format: 16mm, 35mm, 70mm).

Film Gate

Lets you select a preset camera type. Maya automatically sets the Camera Aperture, Film Aspect Ratio, and Lens Squeeze Ratio. To set these attributes individually, set Film Gate to User. The default setting is User.

Camera Aperture

The height and width of the camera's aperture or film back, measured in inches. The Camera Aperture determines the relationship between Focal Length and Angle of View. The default values are 1.417 and 0.945.

3 | Viewing the scene

Reference > Camera node

Film Aspect Ratio

The ratio of the camera aperture's width to its height. Maya automatically updates the Film Aspect Ratio (and vice versa). The valid range is 0.01 to 10. The default value is 1.5.

Film Offset

Vertically and horizontally offsets the resolution gate and the film gate relative to the scene. Changing the Film Offset produces a two-dimensional track. Film Offset is measured in inches. The default setting is 0.

1	The view guide fills the view. The edges of the view guide may be exactly aligned with the edges of the view, in which case the view guide are not visible.
> 1	The higher the value, the more space is outside the view guide.

Depth of Field

These attributes provide control over the camera's focus.

Tip	The more out of focus an image is, the longer it takes to generate the final rendered image (that is, the post-render blur takes longer.)
-----	---

Depth Of Field

If on, some objects in the scene are sharply focused and others are blurred or out of focus, based on their distance from the camera. If off, all objects in the scene are sharply focused. Depth Of Field is off by default.

Focus Distance

The distance from the camera at which objects appear in sharp focus, measured in the scene's linear working unit. Decreasing the Focus Distance also decreases the depth of field. The valid range is 0 to ∞ . The default value is 5.

F Stop

The range of distances from the camera within which objects appear in sharp focus (the depth of field). The range of distances is centered on the Focus Distance. The range is smaller toward the camera and larger away from the camera. The valid range is 1 (small depth of field) to 64 (large depth of field). The default value is 5.6.

Focus Region Scale

Scales the Focus Distance value. The valid range is 0 to ∞ . The default value is 1.

Output Settings

Control whether a camera generates an image during rendering, and what types of images the camera renders.

Renderable

If on, the camera can create an image file, mask file, and/or depth file during rendering. By default, Renderable is on for the default perspective camera, and off for all other cameras.

Note Changing the Camera attribute in the Image File Output section of the Render Globals window can change the Renderable setting in a camera's Attribute Editor.

Image

If on (and Renderable is on), the camera creates an image file during rendering. The default setting is on.

Mask

If on (and Renderable is on), the camera creates a mask during rendering. A mask is an 8-bit channel (the alpha channel) in the image file that represents objects in shades of gray. Black areas represent areas where there are no objects (or fully transparent objects), and white areas represent areas where there are (solid) objects. Masks are used primarily for compositing.

Note If the Image Format in the Render Globals window is *not* set to Maya IFF, Maya16 IFF, RLA, or one of the alpha channel enabled formats which are supported by QuickTime, the camera does not include the mask information in the alpha channel of the image file. Instead, it creates a separate mask file. See also the Render Globals chapter in the Rendering book.

3 | Viewing the scene

Reference > Camera node

Depth

If on (and Renderable is on), the camera creates a depth file during rendering. A depth file is a type of image file that represents the distance of objects from the camera by shades of gray. Depth files are used primarily for compositing. When on, the Depth Type attributes (next) are enabled.

Depth Type

Determines which objects Maya uses to create the Depth file.

Closest Visible Depth

Uses the closest object to the camera. When transparent objects are located in front of other objects, turn on Transparency Based Depth to ignore the transparent object.

Furthest Visible Depth

Most often used when a Particle Effect is occluded by an opaque object. Maya uses the Furthest Visible Depth to create a Depth file.

Transparency Based Depth

Turns on Threshold, which determines which object is closest to the camera, based on transparency. Transparency Based Depth is only enabled when you select Closest Visible Depth.

Tip	When transparent objects are located in front of other objects, you can turn on Transparency Based Depth to ignore the transparent object.
------------	--

Threshold

Used when compositing multiple layers of transparency (which varies from 0 to 1). For example, if Threshold is 0.9 (the default), when transparent surfaces add up to 0.9 or larger, the surface becomes opaque.

Environment

Control the appearance of the scene's background as seen from the camera. Different cameras can use different backgrounds.

Background Color

The color of the scene's background. The default color is black.

Image Plane

Creates an image plane and attaches it to the camera. Clicking the Create button automatically changes the focus of the Attribute Editor to include attributes for an image plane. See the Rendering book for details about Image Plane attributes.

Special Effects

Shutter Angle

Controls the blurriness of motion blurred objects.

In a real-world camera, the shutter is actually a metal disk that is missing a pie-shaped section. This disk sits between the lens and the film, and rotates at a constant rate. When the missing section is in front of the film, it allows light from the lens to pass through and expose the film. The larger the angle of the pie-shaped section, the longer the exposure time, and moving objects are more blurred. Shutter Angle is measured in degrees. The valid range is 1 to 360. The default value is 144.

Note Motion Blur must be on in the Render Globals window and in at least one object's Attribute Editor for the Shutter Angle to have any effect.

Display Options

Controls the display of view guides in the camera's view, and provides options for moving the camera. You can also access most of these attributes in any panel's View > Camera Settings pull-out menu.

Display Film Gate

Displays a rectangle that indicates the area of the camera's view that a real-world camera would record on film. The dimensions of the film gate represent the dimensions of the camera aperture. The film gate view guide indicates the area of the camera's view that renders *only* if the aspect ratios of the camera aperture and rendering resolution are the same.

Display Resolution

Displays a rectangle that indicates the area of the camera's view that renders. The dimensions of the resolution gate represent the rendering resolution. The rendering resolution values are displayed above the resolution gate. See also the Rendering book.

3 | Viewing the scene

Reference > Camera node

Display Field Chart

Displays a grid that represents the twelve standard cel animation field sizes. The largest field size (number 12) is identical to the rendering resolution (the resolution gate). See also the Rendering book.

Display Safe Action

Displays a rectangle indicating the region in which all of the scene's action takes place if you plan to display the rendered images on a television screen. The safe action view guide represents 90% of the rendering resolution (the resolution gate). See also the Rendering book.

Display Safe Title

Displays a rectangle indicating the region in which to keep titles (text) if you plan to display the rendered images on a television screen. The safe title view guide represents 80% of the rendering resolution (the resolution gate). See also the Rendering book.

Journal Command

If on, all camera movements are written to the Script Editor and become part of the undo queue which lets you undo or redo them. This also lets you copy camera movements and use them for other cameras or scenes.

If off, you cannot undo or redo camera movements. Use Previous View or Next View instead. Journal Command is off by default.

Center of Interest

The distance from the camera to the center of interest, measured in the scene's linear working unit.

Tumble Pivot

The point the Tumble tool pivots the camera about when Tumble Camera About is set to Tumble Pivot in the Tumble Tool settings window.

Orthographic Views

When you create a camera from the Create menu, the default view is perspective. If you want an orthographic camera view, click the Orthographic check box and change the Orthographic Width if necessary.

The Orthographic Views attributes also let you control the field of view for orthographic cameras.

4 Transforming objects

About

3D

Transformations

Transformations change an object's position, size, and orientation without changing its shape. "Transform" is basically a fancy way of saying "Move, Scale, and/or Rotate".

Transformations are relative to an object's (or component's) *pivot point*, and take place along/around either the *world axes*, *object axes*, or *local axes*.

In Maya, the transformations you make to an object are saved in a *transform node*. That is, Maya remembers that the object is rotated 32,0,5 degrees and moved -3,6,2,7 cm from its original position.

When you *group* objects together, each group remembers its own transformations. This lets you create hierarchical animations easily.

Related topics

- ❖ "The pivot point" on page 103
- ❖ "World space, object space, and local space" on page 104
- ❖ "Nodes and attributes" on page 149
- ❖ "Move, rotate, or scale objects" on page 110
- ❖ "Set transformation values to zero" on page 115
- ❖ "Group objects together" on page 227

The pivot point

Pivot points control how objects rotate and scale, and also represent the exact locations of objects in space. All transformations to an object are relative to the pivot point:

You can change the pivot point of an object or the selected components by pressing Insert or Home and using the pivot point manipulator.

Transformation	Relationship to Pivot
Move	Moves the pivot point (and the object travels along with it).

4 | Transforming objects

About > World space, object space, and local space

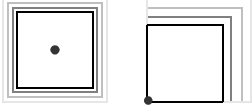
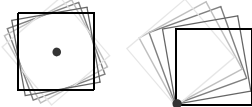
Transformation	Relationship to Pivot
Scale	Scales object out from or in toward the pivot point. 
Rotation	Rotates object around the pivot point. 

Related topics

- ❖ "Change the pivot point" on page 113
- ❖ "Move, rotate, or scale objects" on page 110

World space, object space, and local space

3D positions and transformations exist within *coordinate systems* called *spaces*.

World space is the coordinate system for the entire scene. Its origin is at the center of the scene. The grid you see in view windows shows the world space axes.

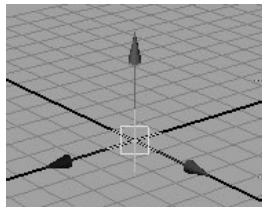

Object space is the coordinate system from an object's point of view. The origin of object space is at the object's pivot point, and its axes are rotated with the object.

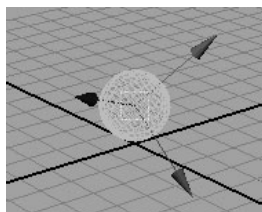

Local space is similar to object space, however it uses the origin and axes of the object's *parent node* in the hierarchy of objects. This is useful when you haven't transformed the object itself, but it is part of a group that is transformed.

Related topics

- ❖ "Transformations" on page 103
- ❖ "The pivot point" on page 103

Maya's interface

Construction history

As you work in Maya, most of your actions create nodes in the construction history of the objects you work on. At each point in your work, the current scene is the result of all the nodes you've created so far.

For example, you can revolve a curve around a centerpoint to create a new surface with a cross-section in the shape of the curve. When you apply this action to the curve, a new revolve node is created. The new node has the shape of the curve as an input. It has attributes that control how it creates the surface from the curve. And it has the resulting surface as its output.



This chain of nodes, from the curve to the revolve node to the surface, is called the surface's *construction history*. The most important thing about construction history is that you can change it. You can reshape the curve, or change the attributes on the revolve node, and the resulting surface updates automatically.

Construction history is part of Maya's *dependency graph*. While construction history refers to the history of actions that created the scene, the entire dependency graph refers to all connections (input and output) between nodes.

Related topics

- ❖ "Edit completed commands (construction history)" on page 121
- ❖ "Show a custom manipulator for the selected node" on page 122
- ❖ "Nodes and attributes" on page 149
- ❖ "Dependency graph" on page 153

4 | Transforming objects

About > Construction planes

Construction planes

A construction plane is a construction aid that can make creating objects with orientations other than along XYZ easier. When you make a construction plane “live”, all drawing is locked to the plane.

Related topics

- ❖ “Snap to the grid, a curve, points, or a view plane” on page 116
- ❖ “Snap all creation tools to a surface or construction plane” on page 117

Copies vs. instances

The Duplicate command lets you create a “real” duplicate or a lightweight “instance” of the original.

This lets you create armies and forests full of duplicate objects without needing the memory or computing power to handle that much actual geometry.

An instance is like an alias or shortcut or symbolic link in a file system. It doesn't have its own shape, it's just a visual pointer back to the original. However each instance has its own transform node so it can have its own position, rotation, and scaling.

An instance stays linked to the original so when the original changes the instance changes too. If you move a control point on the original, all instances automatically update. The instances do not have their own control points.

(In the Outliner an instance appears to have its own shape node but this is actually shared with the original.)

Limitations

- Instanced lights have no effect.
- Some functions, such as extrude and insert, cannot be used on instances.
- You can't apply clusters and deformations to instances, although you can of course use them on the original.
- There is always at least one non-instanced transformation node between the instance nodes and the actual geometry nodes.
- You cannot create a hierarchy of instances. If you create an instance of an instance node, Maya simply makes a new sibling.

4 | Transforming objects

How do I? > Use manipulators

- File referencing connects objects by name. If you replace a reference with a different file, instanced objects within both files should have the same name. Otherwise you may encounter errors when retrieving the scene.

Related topics

- ❖ "Duplicate" on page 124

How do I? Transform objects and components

Use manipulators

The Move, Rotate, and Scale tools show a manipulator on the selected objects. You move, rotate, or scale the objects by dragging handles on the manipulator.

Other tools and objects can also have manipulators. Usually these are the same manipulators (or combinations of the manipulators) used the move, rotate, or scale tools.

Position manipulator

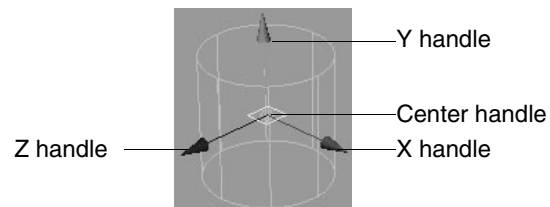

- Drag an arrow to move along that axis.
- Drag the center handle to move freely across the view plane.
- Click a handle to make it active (yellow), then drag the middle mouse button anywhere in a view window to move along the active handle.
- Hold Shift and drag the middle mouse button up and down or left and right to move in that direction.
- In a perspective view, Ctrl-click an arrow to switch the center handle to move across an axis plane.

Ctrl-click the center handle to switch it back to moving across the view plane.

4 | Transforming objects

How do I? > Use manipulators

Rotation manipulator

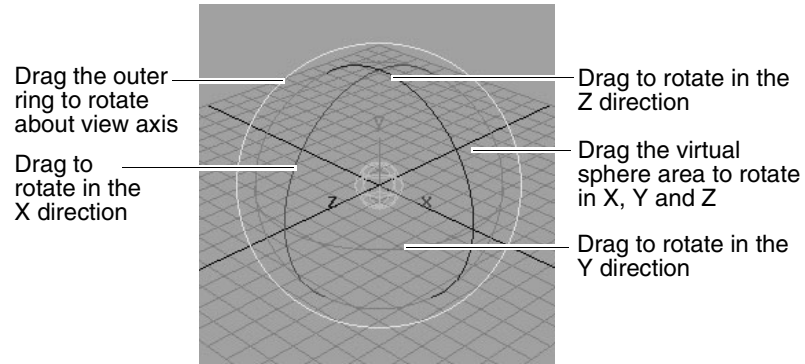

- Drag the rings to rotate around the different axes.
- Drag the outer ring to rotate around the view axis.

Scale manipulator

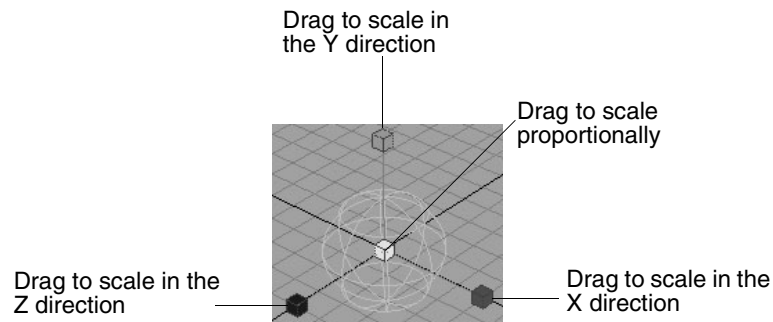

- Drag a box to scale along that axis.
- Drag the center box to scale uniformly in all directions.
- Click a handle to make it active (yellow), then drag the middle mouse button anywhere in a view window to move along the active handle.
- Hold Shift and drag the middle mouse button up and down or left and right to scale in that direction.

4 | Transforming objects

How do I? > Use manipulators

Combined move/rotate/scale manipulator

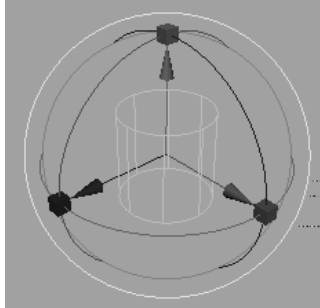

This manipulator combines the handles from the Position, rotation, and scale manipulators in one. The Move/Rotate/Scale tool and Proportional Modification tool use this manipulator.

When a move or scale handle is active, the axis rotation rings are hidden. Click the outer ring rotation ring to show all rotation handles.

Some tools add another handle projecting from the center of the manipulator. Clicking this handle switches the manipulator axes between world and local space.

Complex manipulators

Many objects/nodes have manipulators that let you control the attributes of the node. Often these manipulators are based on the position, rotation and scale manipulators, although some objects and nodes (for example, the spotlight) use complex custom manipulators.

Partial curve manipulators

Some actions (such as Revolve) let you operate on only part of a curve using the Curve Range: Partial option.

When you show manipulators for an action with a partial curve, boundary handles appear on the curve that let you adjust what part of the curve is used.

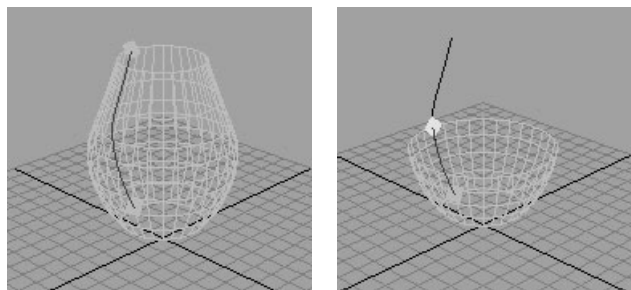

4 | Transforming objects

How do I? > Lock a manipulator to the current selection

Related topics

- ❖ "Transformations" on page 103
- ❖ "World space, object space, and local space" on page 104
- ❖ "Move, rotate, or scale objects" on page 110

Lock a manipulator to the current selection

- 1 Select the object or objects.
- 2 Choose the Move, Rotate, Scale, or Show Manipulator tool.
- 3 Click the Lock current selection icon in the toolbar.

While the lock icon is on, you cannot select other objects using this tool. Clicking or dragging the left mouse button operates the active manipulator handle (like the middle mouse button does normally).

Click the Lock current selection icon again to unlock the manipulator.

Move, rotate, or scale objects

To move

- Choose the Move tool or press w.
- Use the position manipulator to change the position of the selected objects.
- Hold w and press the left mouse button to show a marking menu of options and actions related to the Move tool.

To rotate

- Choose the Rotate tool or press e.
- Use the rotation manipulator to rotate the selected objects. The selection rotates around the pivot of the key object.
- Hold e and press the left mouse button to show a marking menu of options and actions related to the Rotate tool.

To scale

- Choose the Scale tool or press r.
- Use the scale manipulator to scale of the selected objects. The selection scales from the pivot of the key object.
- Hold r and press the left mouse button to show a marking menu of options and actions related to the Scale tool.

4 | Transforming objects

How do I? > Move, rotate or scale components proportionally

To use the combined Move/Rotate/Scale tool

This tool shows the move, rotate, and scale handles all in one manipulator. You may find it easier to use than the individual tools when you're performing a lot of move, rotate, and scale operations on an object to get it into position.

- Choose Modify > Transformation Tools > Move/Rotate/Scale Tool.

To type exact transformation values

- 1 Choose the Move, Rotate, or Scale tools.
- 2 Set the pop-up menu next to the numeric input field to Absolute (abs) or Relative (rel).
- 3 Click the input field and type X, Y, and Z values separated by spaces. You can also type -a or -r before the numeric input to switch to absolute or relative mode. For example -a 5 2 1.

Related topics

- ❖ "Transformations" on page 103
- ❖ "Use manipulators" on page 107
- ❖ "Move, rotate or scale components proportionally" on page 111
- ❖ "Change the pivot point" on page 113
- ❖ "Flip objects" on page 114
- ❖ "Transform along different axes" on page 114
- ❖ "Modify > Transformation Tools > Move Tool, Rotate Tool, Scale Tool, Show Manipulator Tool" on page 135

Move, rotate or scale components proportionally

The Proportional Modification tool lets you move a manipulator and have the surrounding control points follow proportional to their distance from the moving point. This effect is controlled by the Distance Cutoff setting.

4 | Transforming objects

How do I? > Move, rotate or scale components proportionally

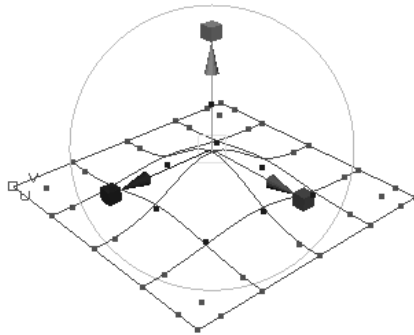

“Proportional modification” is sometimes shortened to *propmod*.

To transform the selected components proportionally

- 1** Select the components you want to modify. Only the selected components are influenced by the tool.
- 2** Choose Modify > Transformation Tools > Proportional Modification Tool > .
- 3** Use the options in the tool options panel to control how distance is measured and how quickly the influence of the manipulator falls off with distance:
 - Set the Modification Type to World to calculate distance in world space. Set it to Parametric to calculate distance across the surface (Parametric only works on NURBS).
 - Set Modification Falloff to Linear to have influence fall off at a steady rate. Set it to Power to have influence fall off very quickly.
- 4** Press Insert or Home to change the manipulator to pivot point mode. Drag the manipulator to move it where you want the center of influence. Press Insert or Home again to change the manipulator back to normal mode.
- 5** Use the other handles on the manipulator to move or scale the selected components based on their distance from the manipulator.

Related topics

- ❖ “Use manipulators” on page 107
- ❖ “Move, rotate, or scale objects” on page 110

Change the pivot point

To move the selected object's pivot

- 1 Choose a transformation tool such as the move tool, rotate tool, or scale tool.
- 2 Press the Insert or Home key to switch the manipulator to pivot point mode.
- 3 Use the manipulator to move the pivot point.
- 4 Press Insert or Home again to switch the manipulator back to normal mode.

To move the pivot point using exact values

- 1 Show the Attribute Editor and click the transform node's tab.
- 2 In the Pivots section, turn on the pivot display options so you can see the effects of editing the pivot values.
- 3 Do one of the following:
 - In the Local Space section, type X, Y, and Z coordinates for the Rotate Pivot and Scale Pivot relative to the object's origin.
 - In the World Space section, type X, Y, and Z coordinates for the Rotate Pivot and Scale Pivot relative to the world origin.

To reset the selected object's pivots to center

- 1 Choose the Rotate or Scale tool.
- 2 Choose Modify > Center Pivot.

To make the selected object's pivot points visible in the scene

- Choose Display > Component Display > Rotate Pivots and Display > Component Display > Scale Pivots.

To keep the pivot in place while working with components

When you transform components, Maya creates a temporary pivot at the center of the selected components. Because the pivot is always at the center of the selection, selecting or deselecting additional components moves the pivot.

You can lock the pivot in place so it won't move as components are added to or removed from the selection.

- 1 Press the Insert or Home key to show the pivot point manipulator.
- 2 Move the pivot point.

4 | Transforming objects

How do I? > Flip objects

- 3 Click the circle at the top of the pivot point manipulator to lock or unlock the pivot point for component transformations. When the circle is filled, the pivot is locked.

Note If the pivot point of an object is changed from its default value, duplicating multiple copies of that object results in additional transforms to the channels of the duplicated transform node. However, the resulting position, orientation and the pivots of the duplicated objects will be correct. To avoid these extra transforms, the duplicate command should be invoked with No of copies set to 1. The hotkey g can then be used as many times as needed.

Related topics

- ❖ "Transformations" on page 103
- ❖ "The pivot point" on page 103
- ❖ "Modify > Center Pivot" on page 144

Flip objects

Scaling an object by a negative amount in one or more directions has the same effect as flipping it across its axes.

- 1 Click the Scale tool and then click the object you want to flip.
- 2 In the toolbar press the right mouse button on the input box and set it to Numeric Input: Absolute or Numeric Input: Relative.
- 3 In the text box, type three numbers representing X, Y, and Z, separated by spaces. To flip the object across an axis, enter -1 for that axis, otherwise type 1.
For example, to flip the object across Y, type 1 -1 1. To flip the object across X and Z, type -1 1 -1.
- 4 Press Enter.

Related topics

- ❖ "Transformations" on page 103
- ❖ "Move, rotate, or scale objects" on page 110
- ❖ "Change the pivot point" on page 113

Transform along different axes

In the Move tool and Rotate tool, you can choose what axes to use.

4 | Transforming objects

How do I? > Set transformation values to zero

Move tool

- Object moves along an object's own rotated axes.
- Local moves along an object's *parent's* rotated axes.
- World moves along the world (grid) axes.
- Normal lets you move CVs on a NURBS surface along U, V, or Normal directions.

Rotate tool

- Local rotates around an object's own axes.
- Global rotates around the world (grid) axes. When this option is on the rings do not rotate with each other but instead stay locked to the world axes.
- Gimbal changes only the X, Y, or Z rotation value. In local and global modes, the rings may change more than one of the rotation XYZ channels.

Related topics

- ❖ "Transformations" on page 103
- ❖ "World space, object space, and local space" on page 104
- ❖ "Move tool" on page 127
- ❖ "Rotate tool" on page 129

Set transformation values to zero

When you transform an object, Maya stores it in a transform node as the difference from its original (zero) position. These menu items let you control this saved transformation information for an object.

To...	Do this
Reset transformations on the selected object back to zero (return to first or last "frozen" position).	Choose Modify > Reset Transformations.
Make the selected object's current transformations be the zero position.	Choose Modify > Freeze Transformations.

4 | Transforming objects

How do I? > Snap to the grid, a curve, points, or a view plane

Related topics





- ❖ "Transformations" on page 103
- ❖ "Modify > Reset Transformations, Freeze Transformations" on page 139

Align and snap

Snap to the grid, a curve, points, or a view plane

When using the Move tool and various creation tools, you can snap to existing objects in the scene.

To snap a move, press the middle mouse button on the object you want to snap to (pressing the left mouse button just selects the object).

To snap to...	Hold	Or turn on this icon in the toolbar
Grid intersections	x	
Curves	c	
CV, vertex, or pivot	v	
View plane		

Note If you have snapping turned on and drag an arrow on the position manipulator (as opposed to the center), the manipulator snaps to the first available point *along that axis*.

Related topics

- ❖ "Snap all creation tools to a surface or construction plane" on page 117

How do I? > Snap all creation tools to a surface or construction plane

Snap all creation tools to a surface or construction plane

You can set a surface so that all creation tools (such as the curve drawing tools) are locked on to the surface. This does not affect actions (such as the create primitives commands).

To snap creation tools to the selected surface

- Click the “Make the selected object live” icon on the toolbar, or choose Modify > Make Live.



While the Make live icon is on, creation tools snap to the surface. Click the icon again to stop snapping to the surface.

To snap creation tools to a plane

- 1 Choose Create > Construction Plane > , set the initial orientation of the plane and click Create.
- 2 Use the Move and Rotate tools to orient the plane.
- 3 Select the plane and choose Modify > Make Live.

While the Make live icon is on, creation tools snap to the surface. Click the icon again to stop snapping to the surface.

Note When you use Make Live to snap a curve to a NURBS surface, the curve becomes a curve-on-surface and you can use it to trim.

For more information, search the online help for Trim Curves

Related topics

- ❖ “Construction planes” on page 106
- ❖ “Snap to the grid, a curve, points, or a view plane” on page 116
- ❖ “Create > Construction Plane” on page 144

Align objects

To align objects using an interactive manipulator

- 1 Choose Modify > Snap Align Objects > Align Tool.
- 2 Select the objects you want to align.

4 | Transforming objects

How do I? > Align objects

The other objects align to the last selected (key) object. This object is highlighted in green.

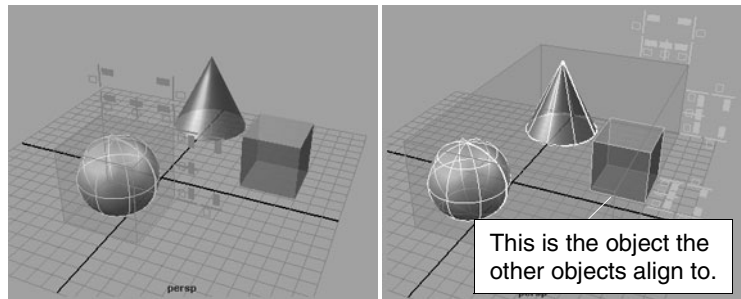

3 Do any of the following:

- Click an icon to align the objects. The icons show how the bounding boxes align. For example:



Align tops.



Align bottoms.



Align centers.



Align tops to the bottom of the key object.

- Use Edit > Undo or press z to reverse an align.

In the following example, the objects align to the far right of the cube outside the transparent box.

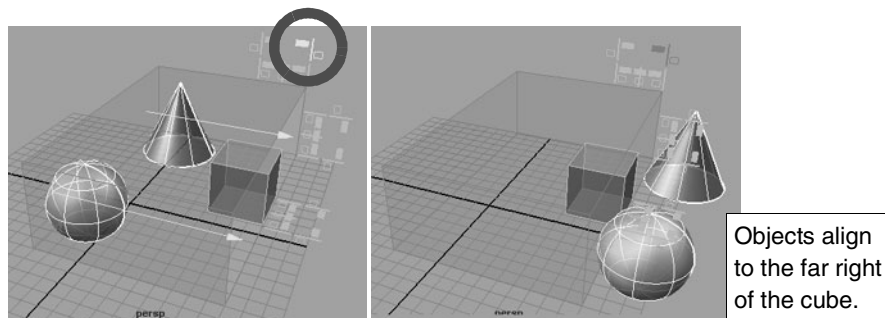

To align objects by setting options

- 1** Select the objects you want to align.
- 2** Choose Modify > Snap Align Objects > Align Objects > .

4 | Transforming objects

How do I? > Snap one object to another

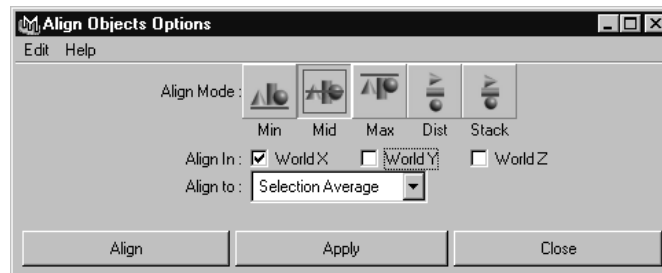

- 3 Choose the align mode. Min aligns objects along the side closest to 0. Max aligns objects to the side farthest from 0. Mid aligns centers. Dist distributes objects equally along the distance between them. Stack moves objects so they are lined up with no space between them.
- 4 Choose which axes to align along. For example, to align tops/bottoms turn on World Y.
- 5 Choose what to move the objects to. Selection Average moves the objects to the average of the object's coordinates. Last selected object moves the objects to the key object. This object is highlighted in green.
- 6 Click Align.

Related topics

- ❖ "Snap one object to another" on page 119
- ❖ "Modify > Snap Align Objects > Align Objects" on page 141
- ❖ "Modify > Snap Align Objects > Align Tool" on page 142

Snap one object to another

To snap objects together with interactive control

- 1 Choose Modify > Snap Align Objects > Snap Together Tool.
- 2 Click the point on the first object you want to snap.
- 3 Click the point on the second object you want to snap to.
- 4 An arrow appears showing how the objects snap together. To change the points, click or drag new points on either object.
- 5 Press Enter to snap the objects together.

The Snap Together Tool normally moves and rotates the objects to make the points touch. Use the tool settings to make the tool move the objects without rotation.

4 | Transforming objects

How do I? > Snap one object to another

Tip You can also use the Snap Together Tool on polygon edges. Press the right mouse button on an object and choose Edge from the marking menu to enter edge selection mode, then apply the Snap Together Tool to polygon edges.

To snap two objects together at one point

- 1 Select the point that will move.
- 2 Shift-select the point to snap to.
- 3 Choose Modify > Snap Align Objects > Point to Point.
Maya moves the first point's object so the two points touch.

To snap two objects together at two points

- 1 Select two points on the object that will move.
- 2 Shift-select two points on the object to snap to.
- 3 Choose Modify > Snap Align Objects > 2 Points to 2 Points.
Maya moves the first object so the first point you selected on each object touch, and the second point you selected on each object touch.

To snap two objects together at three points

- 1 Select three points on the object that will move.
- 2 Shift-select three points on the object to snap to.
- 3 Choose Modify > Snap Align Objects > 3 Points to 3 Points.
Maya moves the first object so the first point you selected on each object touch, the second point you selected on each object touch, and the third point you selected on each object touch.

Related topics

- ❖ "Snap to the grid, a curve, points, or a view plane" on page 116
- ❖ "Snap all creation tools to a surface or construction plane" on page 117
- ❖ "Align objects" on page 117
- ❖ "Modify > Snap Align Objects > Point to Point, 2 Points to 2 Points, 3 Points to 3 Points" on page 140
- ❖ "Modify > Snap Align Objects > Align Objects" on page 141
- ❖ "Modify > Snap Align Objects > Align Tool" on page 142
- ❖ "Modify > Snap Align Objects > Snap Together Tool" on page 143

Change history

Undo, Redo, and Repeat

To...	Do this
Undo.	Choose Edit > Undo or press z.
Redo.	Choose Edit > Redo or press Shift + z.
Repeat the last command.	Choose Edit > Repeat or press g.
Repeat a recent command.	<ul style="list-style-type: none"> • Choose Edit > Recent Commands to show a list of recent commands. • Hold the space bar to open the hotbox and press the left mouse button in the Recent Commands area on the left to show a menu of recent commands.

Related topics

❖ “Edit completed commands (construction history)” on page 121

Edit completed commands (construction history)

Most actions you perform in Maya create a node in the dependency graph.

To select and edit history nodes

- 1 Select the object.
- 2 Do one of the following:
 - Hold the a key and press the left mouse button to show a marking menu of commands related to attributes. Choose Select All Inputs.
 - Press the left mouse button on the input icon in the toolbar and choose a history node from the menu.
 - In the Attribute Editor, click the tab for the history node you want to edit.
 - Click the node’s heading in the Channel Box.
- 3 Edit the node’s attributes in the Attribute Editor or the Channel Box.

4 | Transforming objects

How do I? > Show a custom manipulator for the selected node

To show a custom manipulator for this node, click the Show Manipulator tool in the toolbox.

To temporarily turn off creation of construction history

Click the Construction History On/Off icon on the toolbar.



Related topics

- ❖ "Construction history" on page 105
- ❖ "Dependency graph" on page 153
- ❖ "Edit completed commands (construction history)" on page 121
- ❖ "Show inputs and outputs (dependency graph)" on page 171
- ❖ "Edit > Delete by Type > History" on page 132

Show a custom manipulator for the selected node

Select the node and click the Show Manipulator tool in the toolbox, or choose Modify > Transformation Tools > Show Manipulator Tool.

Show Manipulator Tool 

The manipulator lets you edit the attributes of the node visually.

Related topics

- ❖ "Construction history" on page 105
- ❖ "Nodes and attributes" on page 149
- ❖ "Show or hide the manipulator for an attribute in the Channel Box" on page 161

Create and edit models

Create geometric primitives

Use the items in the Create > Polygonal Primitives, Create > NURBS Primitives, and Create > Subdiv Primitives to add geometric primitives such as spheres, cubes, cylinders, cones, planes, and tori to the scene.

Create text

The Create > Text action lets you create curves or surfaces in the shape of styled text.

- 1 Choose Create > Text > □.
- 2 Type the text you want to create.
- 3 Use the menu button at the right end of the Font box to choose a type face and style.
- 4 Choose one of the following:
 - Click Curves to create NURBS curves from the outline of the text.
 - Click Trim to create planar NURBS surfaces trimmed to the shape of the text.
 - Click Poly to create polygonal surfaces in the shape of the text.
- 5 Click Create.

Notes

- The text is always created starting at the origin in the XY plane. In some views it may appear to be a line because it is edge-on to the view.
- The letters of the text are individual objects in a group. To transform the text, select the group in the Outliner.
- When you use the Curves option, the NURBS curves use CV multiplicity to achieve sharp corners.

Related topics

- ❖ "Create geometric primitives" on page 122
- ❖ "Annotate or document objects" on page 230
- ❖ "Create > Text" on page 144

Edit objects

Delete

To...	Do this
Delete the selection.	Choose Edit > Delete.

4 | Transforming objects

How do I? > Duplicate

To...	Do this
Delete components of a certain type from the selected objects	Choose an item from the Edit > Delete by Type submenu.
Delete all objects of a certain type.	Choose an item from the Edit > Delete All by Type submenu.

Related topics

- ❖ "Edit > Delete" on page 131
- ❖ "Edit > Delete by Type > Channels, Static Channels, Non-particle Expressions" on page 132
- ❖ "Edit > Delete All by Type" on page 132

Duplicate

The Duplicate command lets you create multiple copies of the selected objects, with optional transformations applied to each copy.

You can also make lightweight references to existing objects, known as instances. Instances are linked to the original object, so changing to the original automatically updates all its instances.

To duplicate the selected objects

- 1 Choose Edit > Duplicate > □.
- 2 Set the Geometry Type to Copy.
- 3 Set the options for the number of copies and the transformations to apply to each copy.

Duplicate the selected objects and reapply the last transform

Edit > Duplicate With Transform lets you create a single duplicate of the selected object and automatically apply the last transformation you did with the current manipulator.

For example, if you move an object 2 units up, then choose Edit > Duplicate With Transform, a duplicate object is created and move 2 units up again.

To create lightweight instances of the selected objects

- 1 Choose Edit > Duplicate > □.
- 2 Set the Geometry Type to Instance.

4 | Transforming objects

How do I? > Edit component numeric values directly

- 3 Set the options for the number of copies and the transformations to apply to each copy.

Note If the pivot point of an object is changed from its default value, duplicating multiple copies of that object results in additional transforms to the channels of the duplicated transform node. However, the resulting position, orientation and the pivots of the duplicated objects will be correct. To avoid these extra transforms, the duplicate command should be invoked with No of copies set to 1. The hotkey g can then be used as many times as needed.

Related topics

- ❖ "Copies vs. instances" on page 106
- ❖ "Flip objects" on page 114
- ❖ "Edit > Duplicate" on page 133
- ❖ "Edit > Duplicate with Transform" on page 135

Edit component numeric values directly

With the Component Editor you can view and edit the numeric values of each individual component of an object in a spreadsheet format. For example:

- The stiffness of individual springs.
- The colors of individual particles.
- Polygon vertex colors and normals.
- Weights of CVs, vertices, or lattice points with cluster deformers or after skinning.

4 | Transforming objects

How do I? > Edit component numeric values directly

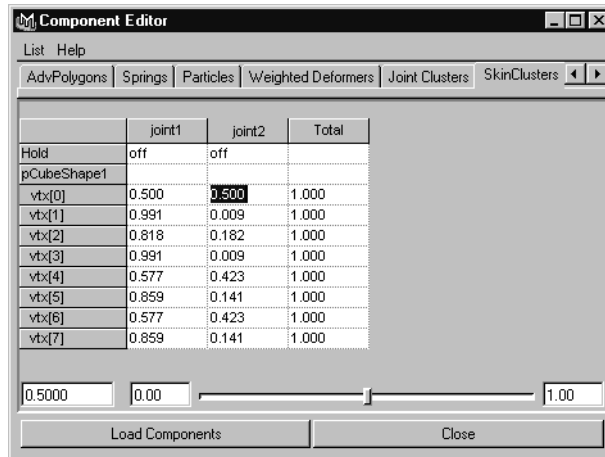

Each component is a row in the spreadsheet. Each value or influence is a column.

To...	Do this
Edit components on an object.	Select the object and choose Window > General Editors > Component Editor.
Show different component types or influences.	Click the tabs across the top of the Component Editor window.
Enter values in cells.	Select all the cells you want to enter the same value in, then type the value or use the slider at the bottom of the window. You can select one or more cells, rows, columns, or any combination.
Switch between always showing the current selection and manually updating the selection.	In the Component Editor, turn List > Auto Update on or off. When Auto Update is off, use the Load Components button to update the window with the current selection.
Change the decimal precision in the cells.	Select List > Change Precision.

Related topics

- ❖ "Component editor" on page 145

Reference Tools

Toolbox

Move tool

Shows a move manipulator for the selected objects or components.

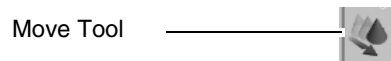

Related topics

- ❖ "Transformations" on page 103
- ❖ "The pivot point" on page 103
- ❖ "World space, object space, and local space" on page 104
- ❖ "Use manipulators" on page 107
- ❖ "Move, rotate, or scale objects" on page 110

Choosing a coordinate system for the Move Tool

Use the Tool Settings options window to specify the coordinate system for the Move Tool.

Object

Moves an object in object space coordinate system. Axis orientation includes rotations on the object itself. If several objects are selected, each object moves the same amount relative to its own object space coordinate system.

Local

Aligns the object to the rotation of the parent object. Movement is constrained to those axes in the local space coordinate system. The object is aligned to the rotation of the parent object and does not include the rotations on the object itself. If several objects are selected, each object moves the same amount relative to its own object space coordinate system.

World

Moves in the world space coordinate system. The object is aligned to the world space axis. This is the default.

4 | Transforming objects

Reference > Move tool

Normal

Moves selected CVs on a NURBS surface in the U or V direction of the surface. Typically you would use this option for small sets of CVs. The manipulator indicates the surface Normal, U, and V directions.

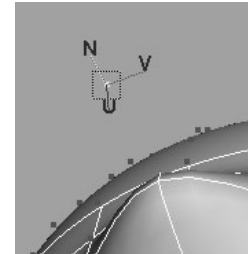

When you select Normal, the Update [UVN] Triad checkbox appears. Turned on, this option causes the manipulator orientation to reflect the moved surface rather than the original surface. This is the default. Turned off, the manipulator retains the orientation for the original surface.

Discrete Move

The Discrete Move setting enables the Relative option and lets you specify the amount an object is moved in increments (determined by the Step Size value).

Relative

While Maya moves the object, relative spacing is maintained. Turn this option off if you don't want to preserve relative spacing while translating.

Step Size

Enter a value to determine the amount an object is moved in increments when the Discrete Move option is selected.

Move Snap Settings

The following settings let you snap to polygon face centers and vertices while translating.

Retain Component Spacing

Turned on by default. This means that while Maya moves the component, relative spacing is maintained. Turn this option off if you don't want to preserve relative spacing while translating and snapping polygonal components.

Snap to Live Polygon—Face Center or Vertex

These settings let you move and snap to a live polygon's components (face centers and vertices).

To snap to components on a live polygon



- 1 Select the polygon you want to snap *to* and click the Make Live icon on the Status Line.
- 2 Double-click the Move icon from the Tool Box to open the Tool Settings window.
- 3 In the Tool Settings window, select a Snap to Live Polygon setting—Face Center or Vertex.
- 4 Click the object you want to move and use the center Move manipulator handle to drag. The movement is restrained to the nearest face centers or vertex locations of the live polygon.

Note: The arrow manipulator handles do not restrain movement.

Rotate tool

Shows a rotation manipulator on the selected objects or components.

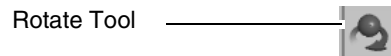

Related topics

- ❖ "Transformations" on page 103
- ❖ "The pivot point" on page 103
- ❖ "World space, object space, and local space" on page 104
- ❖ "Use manipulators" on page 107
- ❖ "Move, rotate, or scale objects" on page 110

Choosing a rotate mode

Local

Rotates the object about the object space axes.

Global

Rotates the object about the world space XYZ axes. Notice that in this mode the rings never change.

4 | Transforming objects

Reference > Scale tool

Gimbal

Changes only the X, Y, or Z rotation value. In local and global modes, the XYZ constraint rings may change more than one of the rotation XYZ channels.

Discrete Rotate

The Discrete Rotate setting enables the Relative option and lets you specify the amount an object is rotated in increments (determined by the Step Size value).

Relative

While Maya rotates the object, relative spacing is maintained. Turn this option off if you don't want to preserve relative spacing while rotating.

Step Size

Enter a value to determine the amount an object is rotated in increments when the Discrete Move option is selected.

Component Use Object Pivot

Lets you rotate object components about the object's pivot point.

Changing the rotation order and axis orientation

In the Transform Attributes section of an object's Attribute Editor, you can change the rotation order of the axes by selecting an order from the Rotate Order pop-up menu. You can also enter values in the Rotate Axis X, Y, or Z boxes to rotate the axes in a specific direction, and to rotate the object around a different axis.

Keep in mind that these attributes have a combined effect with the Rotate Mode settings in the rotate Tool Settings.

Scale tool

Shows a scale manipulator on the selected objects or components.

Scale Tool

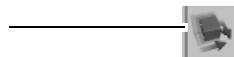

Related topics

- ❖ "Transformations" on page 103
- ❖ "The pivot point" on page 103
- ❖ "World space, object space, and local space" on page 104
- ❖ "Use manipulators" on page 107
- ❖ "Move, rotate, or scale objects" on page 110

Choosing a scale mode

You use the Tool Settings window to specify the behavior for the Scale Tool.

or

Use the marking menu when scaling. Press the letter **r** and the left mouse button over a selected object to display the following marking menu.

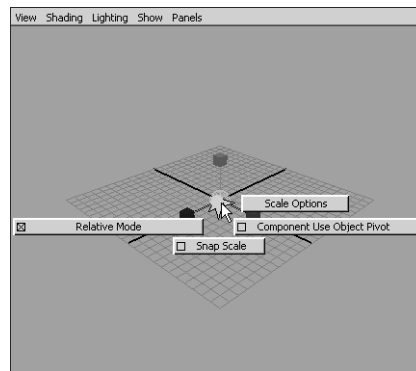

Discrete Scale

The Discrete Scale setting enables the Relative option and lets you specify the amount an object is scaled in increments (determined by the Step Size value).

Relative

While Maya scales the object, relative spacing is maintained. Turn this option off if you don't want to preserve relative spacing while scaling.

Step Size

Enter a value to determine the amount an object is scaled in increments when the Discrete Scale option is selected.

Component Use Object Pivot

Lets you scale object components about the object's pivot point.

Menus

Edit

Edit > Delete

Deletes the selected items.

4 | Transforming objects

Reference > Edit > Delete by Type > History

Edit > Delete by Type > History

Removes construction history from the selection, “baking” it in its current state.

Related topics

- ❖ “Construction history” on page 105
- ❖ “Edit completed commands (construction history)” on page 121
- ❖ “Dependency graph” on page 153

Edit > Delete by Type > Channels, Static Channels, Non-particle Expressions

Hierarchy

To delete the component from the selected object only, choose Selected. To delete the component from the selected object and all objects below it in the DAG hierarchy, choose Below.

Channels

To delete all channels attached to all the selected object’s keyable attributes, select All Keyable. To delete channels attached to those attributes selected in the Channel Box, select From Channel Box. (Instead of Channels, this same option affects Expressions for Non-particle Expressions.)

Driven Channels

Turn this option on to delete driven channels attached to the selected object’s set driven key attributes.

Control Points

Turn this option on to delete channels attached to lattice, polygon, and NURBS curves and surface CVs. If you select All Keyable, this is automatically turned on. The default is off.

Shapes

Removes the object's geometry channels. If you select All Keyable, this is automatically turned on. The default is off.

Edit > Delete All by Type

The items in this submenu let you delete every object of a certain type in the scene.

Related topics

- ❖ "Delete" on page 123

Edit > Duplicate

Creates one or more duplicates of the selection, optionally with transformations applied to each duplicate.

Related topics

- ❖ "Duplicate" on page 124
- ❖ "Edit > Duplicate with Transform" on page 135

Edit > Duplicate >

Translate, Rotate, Scale

Specify the offset values for X, Y, and Z. Maya applies these values to the copied geometry. You can position, scale, or rotate objects as Maya duplicates them.

Note The default for Translate and Rotate is 0.0000. The default for Scale is 1.0000. With the default values, Maya places the copy on top of the original geometry. You can specify offset values (positive or negative floating point) for translation, rotation, and scaling that are then applied to the copied geometry.

Number of Copies

Specify the number of copies to create. The range is from 1 to 1000.

Geometry Type

Select how you want the selected object(s) duplicated.

- | | |
|----------|---|
| Copy | Make a copy of the geometry being duplicated. |
| Instance | Create an instance of the geometry being duplicated. When you create an instance, you do not create actual copies of the selected geometry. Instead, Maya redisplay the geometry being instanced. |

Group under

Group objects under one of the following:

- | | |
|--------|--|
| Parent | Groups the selected objects under their lowest common parent in the hierarchy. |
|--------|--|

4 | Transforming objects

Reference > Edit > Duplicate

World Groups the selected objects under the world (at the top level of the hierarchy).

New Group Create a new group node for the duplicates.

Smart Transform

Turn Smart Transform on so that when you duplicate and transform a single copy or instance of the object (without changing the selection), Maya applies the same transformations to all subsequent duplicates of the selected duplicate.

Tip As a shortcut for duplicating with Smart Transform on, use Edit > Duplicate with Transform.

Duplicate Input Graph

Turn this option on to force the duplication of all upstream nodes leading up to the selected object. Upstream nodes are defined as all nodes with connections feeding into selected nodes.

For example, if A, B, and C are the upstream nodes connecting to D...

A > B > C > D

...and you select D and use the Duplicate Input Graph option, the resultant graph is as follows:

A1 > B1 > C1 > D1

(where A1, B1, C1, and D1 are duplicates of A, B, C, and D respectively).

Duplicate Input Connections

Turn this option on so that in addition to duplicating the selected node, the connections feeding into the selected node are also duplicated.

For example, if A, B, and C are connections feeding into C...

A > B > C

...and you select C and use the Duplicate Input Connections option, then the resultant graph is as follows:

A > B > C and

A > B > C1

(where C1 is a duplicate of C).

Assign Unique Name to Child Nodes

The child node is renamed when the hierarchy is duplicated.

Instance Leaf Nodes

Duplicate entire node hierarchies except for the leaf nodes, which are instanced to the original hierarchy. The new menu item is an improvement over the existing instance menu item, in that all dynamic attributes on the non-leaf nodes are properly duplicated into the new hierarchy.

Edit > Duplicate with Transform

Duplicates the selection and applies the last transformation you did with the current manipulator.

If you do a transform and then make the manipulator go away (for example, but deselecting the object), Maya forgets the last transformation.

Related topics

- ❖ "Duplicate" on page 124

Modify

Modify > Transformation Tools > Move Tool, Rotate Tool, Scale Tool, Show Manipulator Tool

These menu items act the same as clicking the Move tool, Rotate tool, Scale tool, or Show Manipulator tool in the toolbox.

- ❖ "Move tool" on page 127
- ❖ "Rotate tool" on page 129
- ❖ "Scale tool" on page 130
- ❖ "Show Manipulator tool" on page 38

Modify > Transformation Tools > Move Normal Tool

Use the Move Normal Tool to move selected CVs on a NURBS surface in the U or V direction of the surface. This is the same as selecting the Normal option for the Move Tool.

The Update [UVN] Triad check box is turned on by default.

All other settings are the same as the Move tool.

4 | Transforming objects

Reference > Modify > Transformation Tools > Move/Rotate/Scale Tool

- ❖ "Move tool" on page 127

Modify > Transformation Tools > Move/Rotate/Scale Tool

Lets you move, rotate, and scale the selection using a single more complex manipulator.

Related topics

- ❖ "Use manipulators" on page 107
- ❖ "Move, rotate, or scale objects" on page 110

Modify > Transformation Tools > Default Object Manipulator

These items let you use the Move, Rotate, or Scale manipulators with the Show Manipulator tool instead of the custom manipulator for a node.

Choose None to show the node's custom manipulator, rather than a transform manipulator. This is the default.

This information is saved with the scene. It is also shown in the Attribute Editor in the Transform Display section.

Related topics

- ❖ "Use manipulators" on page 107
- ❖ "Show a custom manipulator for the selected node" on page 122

Modify > Transformation Tools > Proportional Modification Tool

Lets you move components based on their distance from a manipulator.

Related topics

- ❖ "Move, rotate or scale components proportionally" on page 111

Modify > Transformation Tools > Proportional Modification Tool >

Modification type

World	Proportional modification happens in XYZ space.
Parametric (NURBS)	Proportional modification happens in UV space.

Modification Falloff: Linear

This is the default modification falloff. Maya performs the modification in a linear fashion and displays the Distance Cutoff option.

Distance Cutoff

Objects further away than this value are ignored. The distance is measured in 3D from the manipulator handle. For Parametric (NURBS) modification type, you set Distance Cutoff U and Distance Cutoff V.

Distance Based On

The distance from the manipulator handle to the object directly influences the modification factor. The distance is computed along the selected axes only. If any of these is turned off, the distance used in the computation of the propmod effect from the handle to the point ignores that component.

Modification Falloff: Power

Using the Proportional Modification Tool, you can set the degree to any value between +5 and -5 and the falloff is non-linear (it forms a logistic curve). However, if you set the degree to 1, the falloff is linear again.

Distance Cutoff

Objects further away than this value are ignored. The distance is measured in 3D from the manipulator handle. For Parametric (NURBS) modification type, you set Distance Cutoff U and Distance Cutoff V.

Degree

Specifies the degree of effect in the U and V directions. A value of 0 applies the transformation equally over the entire region.

A *positive* value *decreases* the effect of the transformation for objects further away from the manipulator handle; the greater the degree, the greater this dampening effect.

If Degree is *negative*, the effect of the transformation is *increased* for objects further away from the manipulator handle.

Distance Based On

The distance from the manipulator handle to the object directly influences the modification factor. The distance is computed along the selected axes only.

Modification Falloff: Script

This method uses a MEL script to determine the falloff.

4 | Transforming objects

Reference > Modify > Transformation Tools > Proportional Modification Tool

With the appropriate parameters set, you can choose the Script option and type a command for the settings in the User Defined Script box to save the current parameter settings without actually invoking the function. If you want to use these settings again later, you can retrieve the tool's script from the Reference Editor.

User Defined Script

The script should return a modification factor. The inputs to the script are "float" numbers. The first three represent the position of the manipulator handle. The second three represent the position of the point manipulated. For example, the points for which this script returns 1 moves with the manipulator handle. The points for which this script returns 0.5 move half as fast as the manipulator handle.

Modification Falloff: Curve

This option uses an animation curve to create the falloff. An animation curve profile can be used to produce a modification factor.

Anim. Curve

Enter the name of an existing animation curve. Its vertical direction maps into the modification factor. The distance maps to the anim curve time axis (in seconds).

You can use the pull-down menu to the right of the box to list and choose all the anim curves with names starting with *propModAnimCurve*. You can also create one of those by choosing Create New from the same pull-down menu.

Scale U, Scale V

For Parametric (NURBS) Modification type only.

Distance Based On

The distance from the manipulator handle to the object directly influences the modification factor. The distance is computed along the selected axes only.

Modification Falloff: NURBS Curve

For World Modification type only. This option uses a NURBS curve to create the falloff. A NURBS curve profile can be used to produce a modification factor.

Enter the name of an existing NURBS curve. Its vertical direction maps into the modification factor. The distance maps to the NURBS curve.

You can use the pull-down menu to the right of the box to list and choose from all the NURBS curves.

Using the PropMod script

The PropMod script is similar to the Move script except that it has additional settings for the move distance. Using the Script option, you can compute each object's factor individually.

The user-defined script command considers both the position of the manipulator and the object. The value returned by the script is used as a multiplying factor for a specific object.

Example

Create myPropMove.mel file as:

```
global proc float myPropMove
    (float $mx, float $my, float $mz,
     float $px, float $py, float $pz)
{
    float $value = rand (1.0);
    return $value;
}
```

...which produces a random value between 0 and 1.

If you select myPropMove as the script name, you get a random modification factor for all selected points.

Modify > Reset Transformations, Freeze Transformations

Reset transformations sets the transformations on the selected objects back to zero. This undoes any transformations since the object was created or the last "freeze".

Freeze transformations makes the current transformations on the selected objects be the objects' zero position.

Tip	Perform a freeze transform before executing operations such as stitch, align, attach, sculpt, wire, and wrinkle; or delete history before doing freeze.
------------	---

Related topics

- ❖ "Set transformation values to zero" on page 115

4 | Transforming objects

Reference > Modify > Snap Align Objects > Point to Point, 2 Points to 2 Points, 3 Points to 3 Points

Modify > Reset Transformations, Freeze Transformations >

Use the options to control which types of transformations (translate/move, rotate, scale, joint orientation) is reset or frozen.

Normals

The normals on polygonal objects will be frozen.

Note You only need to turn on Normals if you are applying Modify > Freeze Transformation to an object that has been sheared, skewed or non-proportionally scaled. Turning on Normals will bake the normals so they will not update if you make subsequent tweaks to the object's shape.

Normals will not be frozen on a polygonal object that has been negatively scaled.

Only for non-rigid deformations

The normals on polygonal objects will be frozen only if it's a non-rigid transformation matrix (that is, a transformation that does not contain shear, skew or non-proportional scaling).

This option is only available when Normals is on.

Modify > Snap Align Objects > Point to Point, 2 Points to 2 Points, 3 Points to 3 Points

Snap objects together at one, two, or three points.

Related topics

❖ "Snap one object to another" on page 119

Options

Move

Object	Apply the transformation to the object itself.
Parent	Apply the transformation to the object's parent.
Grandparent	Apply the transformation to the object two levels up in the scene hierarchy.

4 | Transforming objects

Reference > Modify > Snap Align Objects > Align Objects

Snap Type

Only appears in Snap 2 points to 2 points. You click two pairs of points on the two objects to align them. This option controls what Maya does when the pairs of points are different distances.

Left	Snaps the first and third points you click, and aligns the second and fourth points in the same direction as the first and third.
Middle	Snaps the second and fourth points, aligns the first and third in the same direction.
Right	Snaps the midpoint of the first and third points to the midpoint of the second and fourth, and aligns the other matching points in the same direction.

Modify > Snap Align Objects > Align Objects

Aligns objects in space.

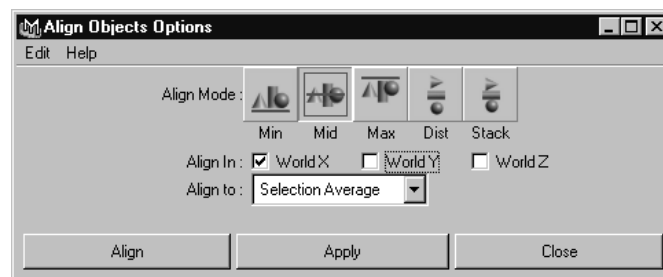

Related topics

❖ "Align objects" on page 117

Modify > Snap Align Objects > Align Objects > □

Align Mode

You can select from one of five different alignment modes according to the objects' bounding boxes.

Min	Aligns objects with the side closest to 0.
Mid	Aligns centers.
Max	Aligns objects with the side farthest from 0.
Dist	Distributes objects evenly along the total distance between them.
Stack	Lines the objects up so there is no distance between their sides.

4 | Transforming objects

Reference > Modify > Snap Align Objects > Align Tool

Align In

You can select an axis or multiple axes in which to align the selected objects. For example, to align tops/bottoms turn on World Y.

Align to

You can use this pull-down menu to specify how to align objects in the Min, Mid, and Max modes. This pull-down menu does not apply to the Dist (Distribute) or Stack modes.

Selection

Average Uses the average minimum, middle, or maximum value of the objects' bounding boxes as the alignment reference.

Last Selected

Object Uses the minimum, middle, or maximum value of the bounding box of the key object as the alignment reference. This object is highlighted in green.

Modify > Snap Align Objects > Align Tool

Lets you align objects visually by clicking icons representing the planes and positions you want to align.

Select the objects you want to align. The other objects align to the last selected (green) object.

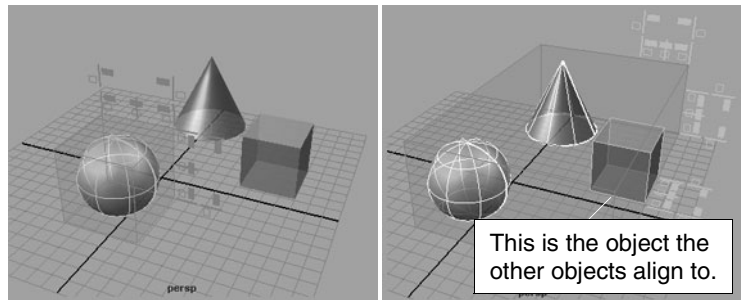

- Click an icon to align the objects. The icons show how the bounding boxes align. For example:



Align tops.



Align bottoms.



Align centers.



Align tops to the bottom of the key object.

- Use Edit > Undo or press z to reverse an align.

4 | Transforming objects

Reference > Modify > Snap Align Objects > Snap Together Tool

In the following example, the objects align to the far right of the cube outside the transparent box.

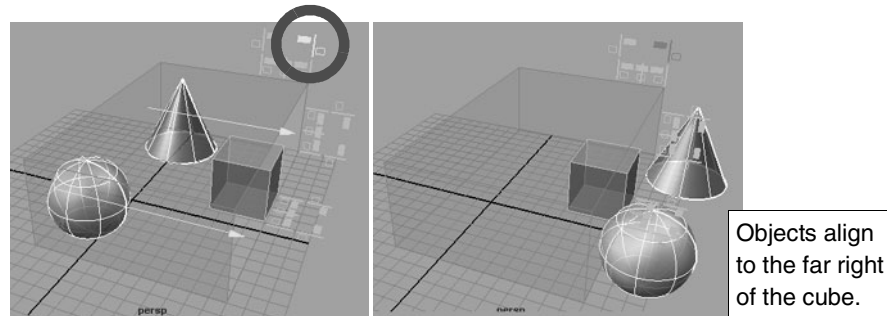

Related topics

- ❖ "Align objects" on page 117

Modify > Snap Align Objects > Snap Together Tool

Lets you visually pick the points on two objects to snap together.

Click a point on one object, then click a point on the second object. You can drag the selected points to edit them. Then press Enter to snap the points together.

Related topics

- ❖ "Snap one object to another" on page 119

Modify > Snap Align Objects > Snap Together Tool > □

Move and rotate object(s)

As the tool snaps the points together, it rotates the moving object so the objects snap together along normals. This can help prevent the objects from intersecting.

Move object(s) only

The tool snaps the points together without rotating the moving object. The objects retain their orientation after the snap.

Snap to Polygon Face

Constrains the snap points to the centers of polygon faces.

4 | Transforming objects

Reference > Modify > Center Pivot

Modify > Center Pivot

Moves the pivot to the center of the object (based on its bounding box).

Related topics

- ❖ "Change the pivot point" on page 113

Create

Create > Text

Adds objects to the scene in the shape of styled text.

Related topics

- ❖ "Create text" on page 123
- ❖ "Annotate or document objects" on page 230

Create > Text > □

Text

Specifies the text to be created.

Font

Typographical style for the text. For details on using a character from an expanded character set on Windows, see the steps that follow.

Type

Curves creates text as NURBS curves you can transform and manipulate.

Trim creates text as trim surfaces. You can render the letters.

Poly creates text as polygons you can transform and manipulate. A planar trim curve is created between the curve and tessellate nodes, but you see only the polygonal surface, not the planar surface.

Create > Construction Plane

Creates a construction plane to which you can snap construction tools.

Related topics

- ❖ "Construction planes" on page 106

- ❖ "Snap all creation tools to a surface or construction plane" on page 117

Create > Construction Plane >

Pole Axis

Sets the orientation of the construction plane. The default is an XY plane.

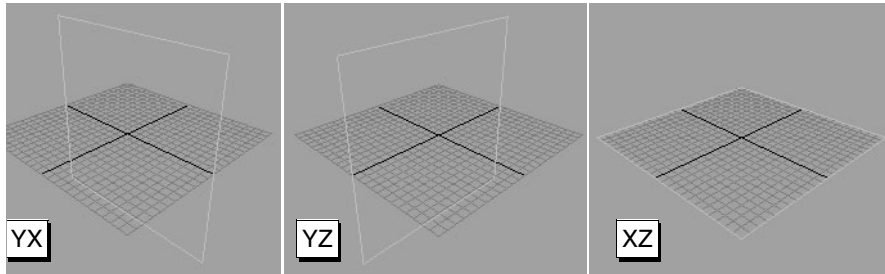

Size

Sets the size of the plane in grid units.

Windows and editors

Component editor

A spreadsheet of values contained in the components of an object.

Related topics

- ❖ "Edit component numeric values directly" on page 125

Menus

Options

Auto Update

Controls whether the editor automatically shows the components of the current selection, or you need to manually update the editor to show the current selection.

When Auto Update is off, click the Load Components button to update the editor with the current selection.

4 | Transforming objects

Reference > Component editor

Hide Zero Columns

When this item is turned on, all columns whose values are zero are hidden (for example, a joint with no influence on vertices in the Smooth Skins tab). When this item is turned off, columns whose values are zero are shown.

Sort Alphabetically

When Sort Alphabetically is turned off, the items that make up the columns are displayed in their order in the hierarchy. When Sort Alphabetically is turned on, the items are sorted in alphabetical order.
Layout

Show Path Name

Shows the path.

Change Precision

Controls how many decimal places Maya shows for numbers in the cells.

Layout

Load Selected Components

This is the same as the Load Components button at the bottom of the window. Updates the editor with the current selection when Auto Update is off.

Show Selected Columns

Removes all columns from the view, except those which are selected. This gives you a way to specify a set of influences/joints and view only them.

Show Selected Objects

Allows you to view only those components which are influenced by a selected object.

For example, create a Smooth Skinned object and select all of its CVs. The Component Editor shows all the CVs. If you select one of the influences and choose Show Selected Objects, you'll see only CVs for that influence; the others will be hidden.

Show All Columns

Shows all columns.

Tabs

Polygons

Lists component data of polygonal vertices, including color or normal data in world space coordinates. If color or normal data are not shared at the vertex level, the column displays the word UnShared. These unshared values can be viewed and edited from the AdvPolygons tab.

AdvPolygons

Lists vertex face component data, including color and normal values for the vertex face.

Weighted Deformers

Lists component data of CVs, vertices, or lattice points influenced by cluster deformers (cluster weights).

Rigid Skins

Lists component data of CVs, vertices, or lattice points bound to a skeleton's joints by rigid skinning (joint cluster weights).

Smooth Skins

Lists component data of CVs, vertices, or lattice points bound to a skeleton's joints by smooth skinning (skin cluster weights).

Springs

Lists component data for springs, including stiffness and damping data.

Particles

Lists component data for particles, including color or velocity data.

Spreadsheet area

- Each component is a row, and each value or influence on the component is a column.
- Click, shift-click, or drag across a cell, column, or row to select it.
- Type a value to enter it in all selected cells.

4 | Transforming objects

Reference > Component editor

5 Nodes and attributes

About Nodes and attributes

Nodes and attributes

Nodes

Maya is built around *nodes*. An “object”, such as a sphere, is built from several nodes: a creation node that records the options that created the sphere, a transform node that records how the object is moved, rotated, and scaled, and a shape node that stores the positions of the spheres control points.

Attributes

An attribute is a position associated with a node that can hold a value or a connection to another node. Attributes control how a node works. For example, a transform node has attributes for the amount of rotation in X, Y, and Z. You can set attributes to control practically every aspect of your animation.

There are many ways to set attributes in Maya: with the Attribute Editor, the Channel Box, the attribute spread sheet, menu selections, and MEL.

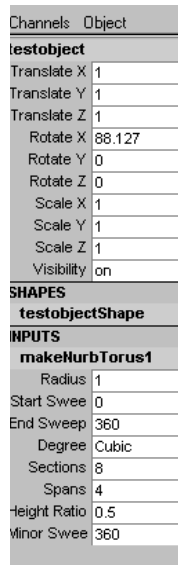

Channel Box

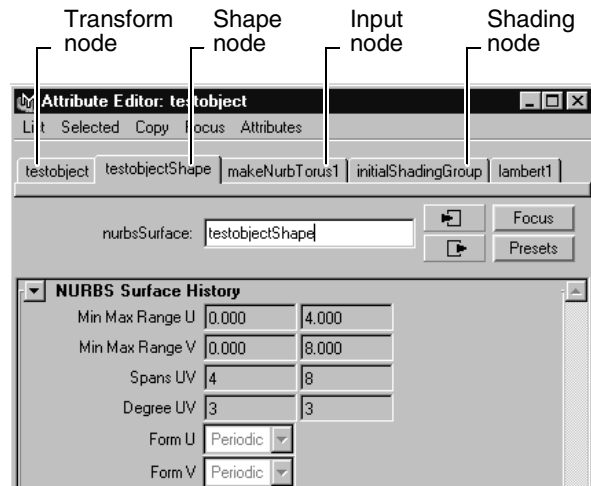

Attribute Editor

5 | Nodes and attributes

About > Nodes and attributes

Every node is created with certain default attributes. Some attributes (such as Opacity and Color of particle objects) are added dynamically when you need them.

You can also add your own attributes to any node to store information. This is often useful for animation expressions and scripts, and can be used to control several normal attributes using one custom attribute.

Related topics

- ❖ “Two views of the scene: hierarchy and dependency” on page 152
- ❖ “Node types” on page 157
- ❖ “Change attribute values in the Attribute Editor or Channel Box” on page 159
- ❖ “View and edit the hierarchy of nodes” on page 168
- ❖ “Show inputs and outputs (dependency graph)” on page 171

Construction history

As you work in Maya, most of your actions create nodes in the construction history of the objects you work on. At each point in your work, the current scene is the result of all the nodes you’ve created so far.

For example, you can revolve a curve around a center point to create a new surface with a cross-section in the shape of the curve. When you apply this action to the curve, a new revolve node is created. The new node has the shape of the curve as an input. It has attributes that control how it creates the surface from the curve. And it has the resulting surface as its output.



This chain of nodes, from the curve to the revolve node to the surface, is called the surface’s *construction history*. The most important thing about construction history is that you can change it. You can reshape the curve, or change the attributes on the revolve node, and the resulting surface updates automatically.

Direct manipulation

Much of working in Maya involves directly manipulating nodes and attributes using *manipulators*.

Manipulators are visual objects that let you accomplish complex tasks easily, concretely, and visually by dragging handles and seeing the results immediately.

5 | Nodes and attributes

About > Nodes and attributes

Using the revolve example above, you can select the revolve node and edit its attributes (how it creates the surface) visually by showing its manipulator with the Show Manipulator tool.

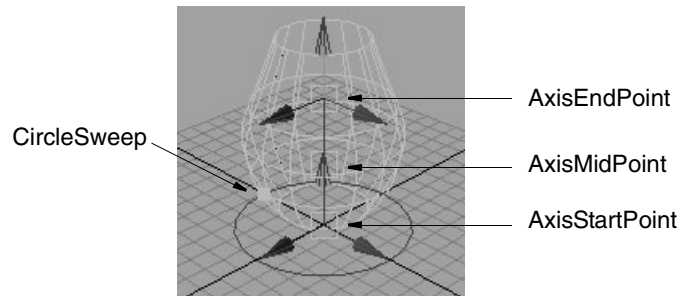

This lets you control attributes (such as how far around the centerpoint the surface goes) simply by dragging a handle.

You can also show manipulators for individual attributes to edit their values visually.

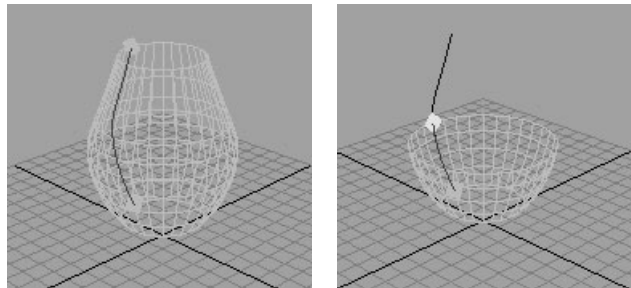

Keyable attributes

Animation in Maya is not limited to making things move. You can animate practically any attribute of any node in Maya. Attributes that control how a surface is constructed, or the look of a texture, or the influence of a deformer or physical force, can all change over time.

MEL

MEL stands for Maya Embedded Language. It is Maya's scripting language. It is deeply integrated with Maya, and allows you to do anything from open a window or perform a simple action with a command, to total customization of the Maya interface, to writing an entirely new application on top of Maya. Practically everything that Maya can do can be accomplished through MEL (and what can't be done in another language with the Maya API).

5 | Nodes and attributes

About > Two views of the scene: hierarchy and dependency

Two views of the scene: hierarchy and dependency

There are two basic ways to view your scene in Maya:

- As a hierarchical list of nodes. This shows which nodes are parents and children of other nodes.
See "Scene hierarchy" on page 152.
- As a graph of connections between nodes. This shows which nodes provide input or output to other nodes.
See "Dependency graph" on page 153.

Scene hierarchy

The scene hierarchy is the grouping of child nodes under parent nodes.

While you could create a scene without establishing a hierarchy, you will find that it makes modeling and especially animation much easier.

You can view and edit the scene hierarchy with the Outliner or the Hypergraph.

Example 1

When you transform a parent, its children are transformed with it. This lets you, for example, model a leg by making the thigh the child of the hip, the knee the child of the thigh, the shin the child of the knee, the foot the child of the shin, and so on. Rotating one joint rotates the rest of the leg under that joint.

Example 2

Suppose you animate a planet to orbit the center of the workspace. If you make a moon the child of the planet, it follows the motion of the planet.

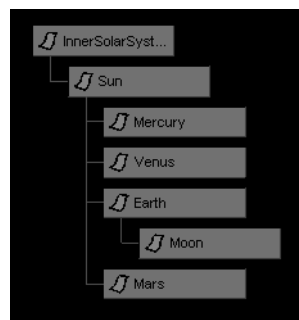

Though the moon is the child of the planet, you can also give the moon motion that's independent of the planet. For example, you can make it orbit the planet. If you later change the orbiting motion of the planet, the moon continues to follow the planet's motion, but still retains its original orbiting motion.

“Parenting”

Among Maya users, establishing hierarchy is often called *parenting objects*. When you make node B the child of node A, we say you have *parented* node B to node A.

(This might be somewhat confusing at first, since “parenting” something does not mean “making it a parent” but rather means “making it a child”, but that's the way it is.)

Grouping

To control multiple objects with one node, you can *group* objects together under a new transform node. By grouping objects, you can move, shade, texture, and do many other actions to all the objects at the same time.

Organizing

You can also use the scene hierarchy to organize objects to make them easier to work with, even if you're not animating them.

Related topics

- ❖ “Nodes and attributes” on page 149
- ❖ “Dependency graph” on page 153
- ❖ “The Outliner” on page 154
- ❖ “The Hypergraph” on page 155
- ❖ “View and edit the hierarchy of nodes” on page 168
- ❖ “Group objects together” on page 227

Dependency graph

The dependency graph is one of two ways Maya represents your scene (the other being the scene hierarchy). It's a chain of nodes.

The dependency graph is like a series of instructions for how to get the current scene starting from scratch: “create a sphere A, move these CVs, create a curve B, project curve B onto sphere A to create curve-on-surface C, trim sphere A using curve on surface C”, and so on.

5 | Nodes and attributes

About > The Outliner

The dependency graph gets its name from the connections between nodes. In the example above, the project curve operation *depends* on two inputs: sphere A and curve B.

Each node in the dependency graph represents an action to build up or change the scene, with the final result being the scene in its current state.

What this lets you do is modify or reshape input objects, change attributes on a node, change node connections, or delete nodes, and have Maya automatically and instantaneously update the entire scene to reflect the changes.

The connections between creation and editing nodes is also called *construction history*, because it records the history of how the scene was constructed.

You can view and edit the dependency graph in the Hypergraph.

Related topics

- ❖ "Construction history" on page 105
- ❖ "Scene hierarchy" on page 152
- ❖ "Edit completed commands (construction history)" on page 121
- ❖ "Show inputs and outputs (dependency graph)" on page 171
- ❖ "Connect input and output attributes" on page 172
- ❖ "Connect attributes with an expression" on page 173

The Outliner

The Outliner is one of two main *scene management* editors in Maya (the other is the Hypergraph).

The Outliner shows the hierarchy of all objects in the scene in outline form: You can expand and collapse the display of branches in the hierarchy, and lower levels of the hierarchy are indented under higher levels.

5 | Nodes and attributes

About > The Hypergraph

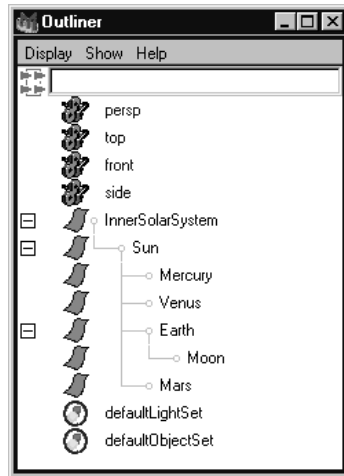

The outline includes objects that are normally hidden in the view panels, such as the default cameras. You can control what objects appear in the Outliner using the menus and the text filter box. For example, type `*top*` in the box and press Enter to only show objects with the letters top in their names.

Clicking the name of a node in the Outliner selects the node. The selected node(s) are shown with a gray background. You can double-click the name of a node to renaming it.

You use the Outliner most often for two functions:

- Selecting objects. With complex scenes it is often easier to select an object by clicking its name in the Outliner than trying to hit it in a view panel.
- Changing the hierarchy of nodes. You can move nodes around the hierarchy and parent nodes to other nodes by dragging them with the middle mouse button.

Related topics

- ❖ "Nodes and attributes" on page 149
- ❖ "The Hypergraph" on page 155
- ❖ "View and edit the hierarchy of nodes" on page 168
- ❖ "Outliner" on page 185

The Hypergraph

The Hypergraph is one of two main *scene management* editors in Maya (the other is the Outliner).

5 | Nodes and attributes

About > The Hypergraph

The Hypergraph shows a network of boxes representing nodes and lines connecting them representing relationships.

You can use the Hypergraph to view and edit hierarchical relationships (the same information the Outliner shows) or dependency relationships (input and output connections between attributes).

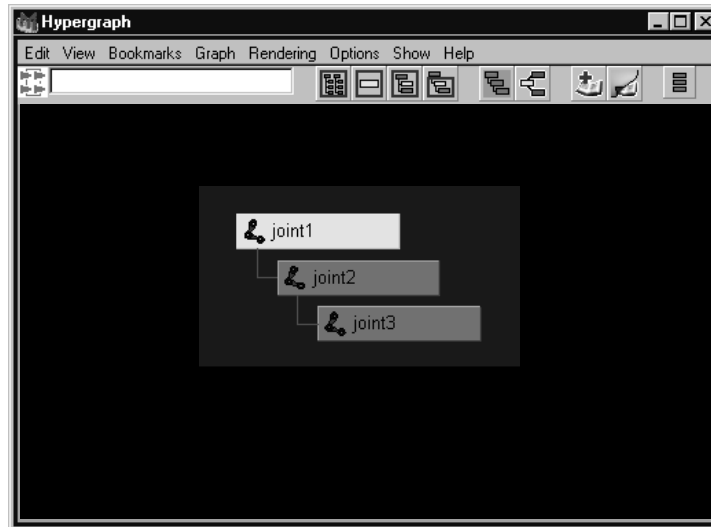

While the Hypergraph can seem more intimidating than the Outliner at first, it has several advantages of its own:

- You can use it to show and edit connections between nodes.
- You use the same move keys to move around the graph as you do to move around view panels (alt + the middle mouse button and alt + the right mouse button).
- You can bookmark different views of the scene and zoom between them
- The Hypergraph draws animated nodes with slanted sides making them easy to see.

Related topics

- ❖ "Nodes and attributes" on page 149
- ❖ "The Outliner" on page 154
- ❖ "View and edit the hierarchy of nodes" on page 168
- ❖ "Show inputs and outputs (dependency graph)" on page 171
- ❖ "Connect input and output attributes" on page 172
- ❖ "Connect attributes with an expression" on page 173
- ❖ "Hypergraph" on page 202

Node types

Transform node

A node that contains an object's transformation attributes—values for its translation, rotation, scale, and so on. It also holds information on parent-child relationships it has with other nodes. InnerSolarSystem, Sun, Moon, and all other boxes shown in the example are transform nodes.

Shape nodes

Holds an object's geometry attributes or attributes other than the object's transform node attributes. A shape node is the child of a transform node. A transform node has only one shape node.

Auxiliary nodes

There are several nodes, such as unitConversion, that Maya hides them to reduce clutter in the editors. They are not normally useful to see or edit, however if you need to you can show these nodes. (You can also hide nodes that are normally shown if you want to further reduce clutter.)

Hidden nodes

Any object hidden using Display > Hide. Maya hides the default cameras (top, front, side, and persp) by default.

Underworld nodes

A pair of nodes below a shape node. When you create a curve-on-surface, Maya creates an underworld transform node and shape node for the curve-on-surface below the surface's shape node. The CV positions of underworld nodes have UV coordinates on the surface rather than coordinates in world or local space.

Rendering nodes

Materials and textures each have nodes containing attributes that control their look. Texture placement nodes have attributes that control how a texture is fitted onto a surface.

Lights are of course nodes too, with attributes controlling their properties.

Utility nodes

Maya has a few utility nodes that provide extra functions you can use in a shader network. For example, multiply/divide nodes let you alter inputs and outputs between other nodes.

5 | Nodes and attributes

About > Node types

Script nodes

Script nodes are a way of storing a MEL script in a Maya scene file:

You can set a script node to execute its “payload” in response to various events:

- When the node is read from a file.
- Before or after rendering a frame.
- Before or after rendering an animation.
- When a file is closed or de-referenced.

Examples

Example 1

If you select Create > NURBS Primitives > Sphere to create a sphere, Maya creates a transform node and a shape node.

The sphere’s shape node holds the mathematical description of the sphere’s shape. The sphere’s transform node holds the sphere’s position, scaling, rotation, and so on. The shape node is the child of the transform node.

If you select Options > Display > Shape Nodes in the Hypergraph, the scene hierarchy shows these nodes for the sphere:

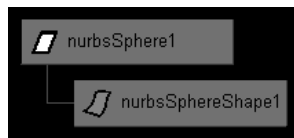

Maya gives the nodes the default names shown in the preceding figure. The transform node is nurbsSphere1, the shape node is nurbsSphereShape1. If you rename the transform node, for example, to Bubble, Maya renames the shape node to BubbleShape.

If you rename the shape node, Maya does not rename the transform node. Maya doesn’t transmit a child’s attribute changes up to its parent.

Example 2

If you select Create > NURBS Primitives > Sphere to create a sphere, Maya creates a transform node and a sphere node. If you then select Modify > Make Live, then use the Create > CV Curve Tool to draw a curve on the surface of the sphere and turn on the display of shape nodes and underworld nodes, the scene hierarchy appears as follows:

How do I? > Change attribute values in the Attribute Editor or Channel Box

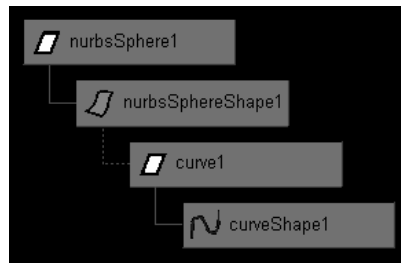

Maya gives the nodes the default names shown. The transform node is `nurbsSphere1`, the shape node is `nurbsSphereShape1`. The `curve1` and `curveShape1` nodes are underworld nodes for the curve created on the sphere's surface.

When a curve-on-surface is hard to select in the workspace because of crowding or complex geometry, you can select it easily in the scene hierarchy with underworld nodes displayed.

Related topics

- ❖ "Nodes and attributes" on page 149
- ❖ "Scene hierarchy" on page 152
- ❖ "Dependency graph" on page 153

How do I? **Work with nodes and attributes**

View and edit attributes





Change attribute values in the Attribute Editor or Channel Box

Attribute values with an purple background in the Channel Box or Attribute Editor are controlled by a connection to another attribute. You cannot edit them manually.

To...	Do this
Enter a value for an attributes	Click in the text box and type a new value and press Enter. For boolean (on/off) values, type 1 or on, or 0 or off.

5 | Nodes and attributes

How do I? > Change attribute values in the Attribute Editor or Channel Box

To...	Do this
Change a value and return the keyboard focus to the view windows so you can use hotkeys.	Type the value and press the Enter or Return key.
Change a value and leave the keyboard focus in the edit box.	Type the value and press the Enter key on the numeric keypad.
Enter the same value in multiple attributes at once.	Shift-click, Ctrl-click, or drag across multiple text boxes to select them. Then type a new value and press Enter.
Change the sensitivity of sliders in the Channel Box.	<ul style="list-style-type: none"> Click the slider speed icon to switch between slow, medium, and fast sliders. Click the hyperbolic icon to switch to a hyperbolic scale. This causes the value to change <i>very fast</i>. Use this for values that need large adjustments.
Adjust the value of a numeric attribute with the mouse.	<ul style="list-style-type: none"> Click the attribute and drag left or right with the middle mouse button. Use the icons in the Channel Box toolbar to control the mapping between mouse move distance and numeric change. <div style="display: flex; justify-content: space-around; align-items: center;"> <div style="text-align: center;">  Slow </div> <div style="text-align: center;">  Medium </div> <div style="text-align: center;">  Fast </div> </div> <div style="display: flex; justify-content: space-around; align-items: center; margin-top: 10px;"> <div style="text-align: center;">  Linear </div> <div style="text-align: center;">  Hyperbolic </div> </div>
Enter a value relative to the current one.	<ul style="list-style-type: none"> Type $+=\underline{n}$ to add \underline{n} to the current value. Type $-\underline{n}$ to subtract \underline{n} from the current value. Type $*=\underline{n}$ to multiply \underline{n} by the current value. Type $/=\underline{n}$ to divide the current value by \underline{n}.

How do I? > Show or hide the manipulator for an attribute in the Channel Box

To...	Do this
Quickly link the attribute to another value. (<i>Attribute Editor only</i>)	You can type <code>=time</code> or <code>=frame</code> in the text box to use the reserved keywords <code>time</code> or <code>frame</code> and link the value of the attribute to the current time or the current frame. You can also include simple operators; for example, <code>=frame/2</code> , <code>=time*3.5</code> .
Create a complex expression	Right-click on the text box and choose Create New Expression (Attribute Editor) or Expressions (Channel Box). See the <i>MEL</i> book for details on creating and using expressions.

Tip When typing values in the Channel Box:

- Press the Enter key on the numeric keypad to enter a value and keep the focus in the Channel Box.
- Press the Enter key on the keyboard to enter the value and return focus to the view windows (so you can use hotkeys).

Related topics

- ❖ "Show or hide the manipulator for an attribute in the Channel Box" on page 161
- ❖ "View and edit multiple attributes on multiple nodes" on page 162
- ❖ "Save and reuse attribute presets" on page 164
- ❖ "Lock the value of an attribute" on page 166
- ❖ *Creating animation expressions*

Show or hide the manipulator for an attribute in the Channel Box

Normally when you click an attribute name, a manipulator appears on the selected object to control that attribute, and you can also drag the middle mouse button to change the attribute's value. You can disable the manipulator and dragging features.



Standard
Manips



Invisible
Manips



No
Manips

5 | Nodes and attributes

How do I? > View and edit multiple attributes on multiple nodes

To...	In the Channel Box, choose...
Prevent the manipulator from appearing when you click an attribute name.	Channels > Settings > Invisible Manips.
Prevent the manipulator from appearing and disable dragging the middle mouse button.	Channels > Settings > No Manips.
Show the manipulator when you click an attribute name and allow dragging the middle mouse button.	Channels > Settings > Standard Manips.

Related topics

- ❖ "Change attribute values in the Attribute Editor or Channel Box" on page 159

View and edit multiple attributes on multiple nodes

The attribute spread sheet lets you edit the values of many attributes on many nodes at the same time by presenting them in a spreadsheet format.

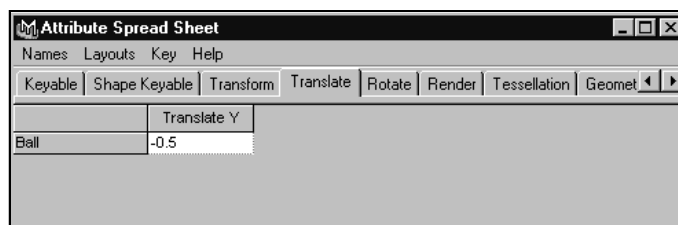

To...	Do this
Open the attribute spread sheet.	Select a node and choose Windows > General Editors > Attribute Spread Sheet.

5 | Nodes and attributes

How do I? > View and edit multiple attributes on multiple nodes

To...	Do this
Enter values in cells.	Select all the cells you want to enter the same value in, then type the value. You can select one attribute, multiple attributes on the same object, or the same attribute on multiple objects, or any combination.
Enter a value relative to the current one.	<ul style="list-style-type: none"> • Type +=<u>n</u> to add <u>n</u> to the current value. • Type -=<u>n</u> to subtract <u>n</u> from the current value. • Type *=<u>n</u> to multiply <u>n</u> by the current value. • Type /=<u>n</u> to divide the current value by <u>n</u>.
Switch to short attribute names to save room.	In the attribute spread sheet, select Names > Short Attribute Names.
Display different types of attributes.	Click the tabs across the top of the attribute spread sheet window. Many useful attributes of an object are not stored in its main node, but instead in its shape node. The Attribute Editor includes tabs that show attributes from an object's associated shape node.
Only show certain attributes.	In the attribute spread sheet, click, shift-click, or drag to select the attributes (columns) you want to show. Then select Layouts > Show Selected Columns Only. To return to the full display, select Layouts > Show All Columns.
Save the current layout of visible columns as a new tab.	In the attribute spread sheet, select Layouts > Remember This Layout. The attribute spread sheet now has a new tab that shows the layout. To delete a layout tab, click the tab and select Layouts > Delete Current Layout.

5 | Nodes and attributes

How do I? > Save and reuse attribute presets

To...	Do this
Key certain attributes.	Select the cells and choose Key > Key Selected.

When the Attribute Editor opens for the first time, the Keyable tab is shown. This tab only shows attributes that are marked as keyable (able to be animated). Click the All tab to show all attributes, keyable and not.

Related topics

- ❖ "Change attribute values in the Attribute Editor or Channel Box" on page 159
- ❖ "Show or hide the manipulator for an attribute in the Channel Box" on page 161
- ❖ "Open multiple Attribute Editors" on page 167

Save and reuse attribute presets

The Attribute Editor lets you save and re-apply *presets*. A preset is a collection of attribute settings you can save from one node and reapply to any number of other nodes.

This lets you store complex node setups, such as a library of lights set up with the attribute values you want.

Maya comes with a variety of presets for various nodes, such as fluids.

To create a preset

- 1 Open the node you want to take presets from in the Attribute Editor.
- 2 In the Attribute Editor, press the left mouse button on the Presets button (to the right of the node name) to show a pop-up menu and choose Save (preset type) Preset.

5 | Nodes and attributes

How do I? > Save and reuse attribute presets

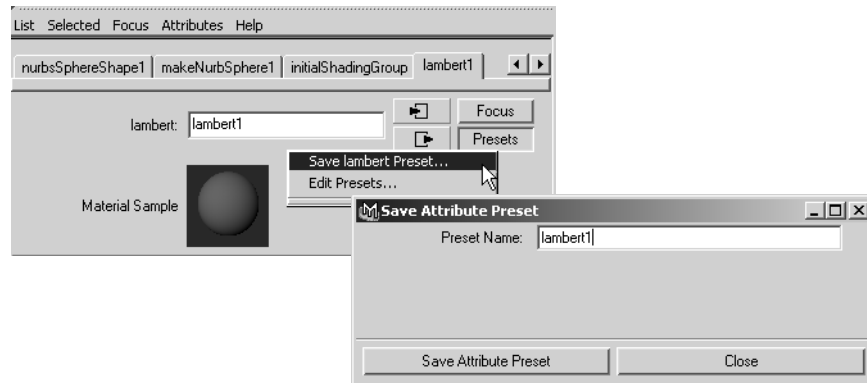

3 Type a name for the new preset and click Save Attribute Preset.

If the preset already exists, you are prompted to overwrite it or save it with a different name.

To apply a preset to another node

- 1** Open the node you want to apply a preset to in the Attribute Editor.
- 2** In the Attribute Editor, press the left mouse button on the Presets button (to the right of the node name) to show a pop-up menu.
- 3** Point to the name of the preset to show another sub-menu with options for applying the preset to this node. You can replace the current attribute values with the values in the preset, or blend the preset values together with the current values.

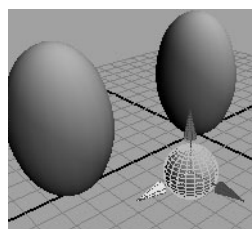

1. Create a new poly sphere.

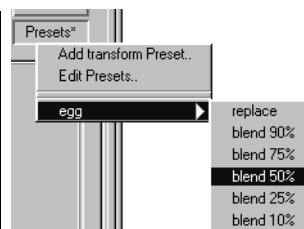

2. Select **egg** and a blend value of 50%.

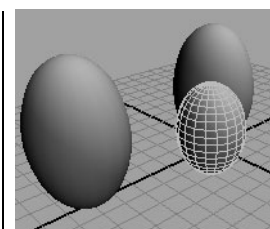

3. The result is an egg 50% smaller than the original.

Notes

- Presets do not save connections to other nodes (such as texture maps). Applying a preset does not overwrite connections to other nodes.
- Maya saves presets as editable MEL scripts in a `presets` folder inside the main Maya application folder. Presets for each node type are in separate folders inside the `presets` folder.

5 | Nodes and attributes

How do I? > Lock the value of an attribute

What if...?

The Presets button is grayed out?

Some node types cannot be saved as presets. Shape nodes, for example, would be meaningful as presets.

Related topics

- ❖ "Change attribute values in the Attribute Editor or Channel Box" on page 159
- ❖ "Lock the value of an attribute" on page 166

Lock the value of an attribute

Press the right mouse button on the attribute and choose Lock Attribute. Maya displays locked attributes with a gray background.

To unlock an attribute, press the right mouse button on the attribute and choose Unlock Attribute.

Create, edit, or delete custom attributes

To add custom attributes to objects

- 1 Select the objects/nodes you want to add attributes to.
- 2 In the Attribute Editor, choose Attributes > Add Attributes.
- 3 Type the name of the attribute.
- 4 Choose the type of value the attribute holds:
 - Vector: three floating point values.
 - Float: a single floating point value. Maya does not display floating point numbers in the user interface with their full precision.
 - Although Maya only displays numbers to a customizable number of decimal places, and the Attribute Editor always shows only three decimal places, the true value of a float attribute is kept in memory.
 - Integer: a single integer value.
 - Boolean: an on/off switch.
 - String: a text string.
 - Enum: a list of choices.
- 5 Set the Keyable option. When an attribute is keyable, you can use its value in keyframe animation, and it appears in the Channel Box.
- 6 Click Add.

5 | Nodes and attributes

How do I? > Open multiple Attribute Editors

Remember that Maya adds the attribute to the selected node, not necessarily the node currently displayed in the Attribute Editor.

To edit a custom attribute

- 1 Select the object/node with custom attributes you want to edit.
- 2 Choose Modify > Edit Attributes.
Or, in the Attribute Editor, choose Attributes > Rename Attributes.
In attribute names, all punctuation except for the underscore (_) and the pound sign (#) are illegal characters
- 3 Click the name of the attribute.

To delete a custom attribute

- 1 Select the object/node with custom attributes you want to delete.
- 2 Choose Modify > Delete Attributes.
- 3 Click the name of the attribute.
- 4 Click Delete.

Open multiple Attribute Editors

- 1 Choose Window > Attribute Editor to show the Attribute Editor.
- 2 Select the first object.
- 3 In the Attribute Editor, click Copy Tab. A new Attribute Editor is created with the object attributes loaded.
- 4 Select another object. Its attributes load in the original Attribute Editor.

You can set an option in Window > Settings/Preferences > Preferences to always open the Attribute Editor in a window instead of in the side panel.

Related topics

- ❖ "Window > Settings/Preferences > Preferences" on page 298

Control the display of attributes in the Channel Box

To change the display precision of floating point attribute values

- 1 In the Channel Box choose Channels > Settings > Change Precision.
- 2 Type the number of decimal places to show in the Channel Box and attribute spread sheet.

5 | Nodes and attributes

How do I? > View and edit the hierarchy of nodes

To change the display of attribute names

The default (“Nice”) attribute names in the Channel Box are easy to read, but cannot be used in expressions or MEL scripts. To show the actual internal names of the attributes, use the Long or Short options.

- 1 In the Channel Box, open the Channels > Channel Names submenu.
- 2 Do one of the following:
 - Choose Nice to show attribute names that are easier to understand, but cannot be used in expressions or MEL scripts. This is the default.
 - Choose Long to show the long versions of the actual attribute names.
 - Choose Short to show the short versions of the actual attribute names.

To change the width of the Channel Box

Click the << or >> button at the bottom of the Channel Box to resize it.

Related topics

- ❖ “Change attribute values in the Attribute Editor or Channel Box” on page 159

View and change the hierarchy of nodes

View and edit the hierarchy of nodes

To...	Do this
Show scene hierarchy in the Hypergraph.	<ol style="list-style-type: none">1 Choose Window > Hypergraph.2 In the Hypergraph, choose Graph > Scene Hierarchy.
Show scene hierarchy in the Outliner.	Choose Window > Outliner.

5 | Nodes and attributes

How do I? > View and edit the hierarchy of nodes

To...	Do this
Move a node under another (parent) node.	<ul style="list-style-type: none">• In the Hypergraph or Outliner, drag the node onto the parent with the middle mouse button.or• Select the objects you want to assign to the parent, then shift-select the parent and choose Edit > Parent.
Remove a node from the hierarchy under another node (unparent).	<ul style="list-style-type: none">• In the Hypergraph or Outliner, drag the node away from its parent with the middle mouse button.or• Select the child object you want to remove from under the parent and choose Edit > Unparent > □.

Tips

- You can set the options of the Parent menu item to make the command create an instance under the new parent instead of moving the actual object in the hierarchy.
- Unparenting an object removes it from under its parent's transformation node, which can change the object's position in the scene.

Open the Unparent menu item's options and turn on the Preserve Position option to apply the transformations to the object as it is unparented so it retains its current position.

Related topics

- ❖ "Change the visual layout of nodes in the Hypergraph" on page 170
- ❖ "Change the order of nodes" on page 171
- ❖ "Show or hide nodes" on page 175

5 | Nodes and attributes

How do I? > Change the visual layout of nodes in the Hypergraph

Change the visual layout of nodes in the Hypergraph

To...	Do this
Switch between automatic and manual layout.	Choose one of the following: <ul style="list-style-type: none">Options > Layout > Automatic Layout.Options > Layout > Freeform Layout.
Move nodes in freeform layout.	Drag nodes with the left mouse button.
Display an image in the background of the freeform layout.	To load an image, choose View > Load Background Image. To turn the image on or off, Options > Display > Background Image.
Reset the positions of nodes in the freeform layout.	Choose Edit > Reset Freeform Layout.
Switch the automatic layout between stacking root nodes horizontally or vertically.	Choose one of the following: <ul style="list-style-type: none">Options > Orientation > Horizontal.Options > Orientation > Vertical.
Change the color of nodes as they display in the Hypergraph.	In the <i>Attribute Editor</i> for that node, go to Drawing Overrides. (You may have to expand Object Display to see this section.) Turn on Enable Overrides and set a color using the color slider. You must have Node Display Override Color turned on in the <i>Hypergraph</i> to display color changes. Changing the color of a layer overrides this node display setting.

Related topics

- ❖ "Two views of the scene: hierarchy and dependency" on page 152
- ❖ "The Hypergraph" on page 155
- ❖ "Hypergraph" on page 202

Change the order of nodes

When Maya draws or renders the scene, it looks at each node in the scene in order and applies the node's effect (for example, creating an object or applying a rotation) to the scene. In certain limited situations, the order in which Maya evaluates nodes can affect the final result.

To view the nodes in order

- In Outliner (Window > Outliner), choose Display > Sort Order > Scene Hierarchy.
- In the Hypergraph (Window > Hypergraph), choose Graph > Scene Hierarchy and then Options > Layout > Automatic Layout.

To change the order of nodes in the Outliner

Drag a node with the middle mouse button and drop it between nodes.

As you drag, Maya draws a single line to indicate that dropping the node results in reordering, or a double line (above and below the target) to indicate that dropping the node makes it a child of the target node.

To change the order of nodes in the Hypergraph

Hold Ctrl, drag a node with the middle mouse button, and drop it on the node you want it to precede in the order.

Related topics

- ❖ "Scene hierarchy" on page 152
- ❖ "The Outliner" on page 154
- ❖ "Outliner" on page 185

View and change input and output history relationships between nodes

Show inputs and outputs (dependency graph)

To show connections between nodes

- 1 Open the Hypergraph (Window > Hypergraph).
- 2 Choose one of the following menu items in the Hypergraph:
 - Choose Graph > Input and Output Connections to show both the input chains leading up to nodes, and the output chains leading from nodes.

5 | Nodes and attributes

How do I? > Connect input and output attributes

- Choose Graph > Input Connections to show the input chains leading up to nodes.
- Choose Graph > Output Connections to show the output chains leading from nodes.

To show connections for only certain types of nodes

- 1 Select a node of the type, or multiple nodes of different types you want to show.
- 2 In the Hypergraph, select Show > Show Selected Type(s).
- 3 To show all nodes again, choose Show > Show All.

To show connections for a node or nodes in the Outliner or hypershade window

- 1 Set up the Hypergraph to show connections.
- 2 Drag the node from the Outliner or hypershade window into the Hypergraph.

Show or hide extra connections

You can show color-coded lines between nodes representing expression, constraint, and deformer connections in the Hypergraph.

Choose the following menu items in the Hypergraph to show or hide different types of connections:

- Options > Display > Expression Connections.
- Options > Display > Constraint Connections.
- Options > Display > Deformer Connections.

Related topics

- ❖ "Connect input and output attributes" on page 172
- ❖ "Connect attributes with an expression" on page 173
- ❖ "Show or hide nodes" on page 175

Connect input and output attributes

To connect attributes in the Hypergraph using context menus

- 1 Point to the right end of the node in the Hypergraph (the cursor changes). Press the right mouse button and choose an output attribute.
- 2 Press the right mouse button on the node you want to connect to, and choose an input attribute.

You may need to choose Graph > Layout to update the view with the new connection.

To connect attributes in the Hypergraph using the Connection Editor

- 1 Hold Shift and drag with the middle mouse button from the output node to the input node.
- 2 Use the Connection Editor to choose which attributes to connect.

To change the input or output of a connection

- 1 Point to the connection line in the Hypergraph, toward the connection you want to change (input or output).
- 2 Drag the line end with the left mouse button and drop it on a new node.
- 3 Choose the attribute you want to connect.

Related topics

- ❖ "Connect input and output attributes" on page 172
- ❖ "Connect attributes with an expression" on page 173
- ❖ "Break connections between attributes" on page 174

Connect attributes with an expression

To connect the value of one attribute to another with an expression

- In the Attribute Editor, type an equals sign (=) followed by a MEL expression in the attribute's text box.
or
- Select the node with the attribute you want to edit and choose Window > Animation Editors > Expression Editor. Click the attribute and type a MEL expression in the box at the bottom.

For example, to make the translateX value of pTorus1 always equal the translateY value of pCone2, type =pCone2.translateY in pTorus1's translateX box. When you move the cone up and down in Y, the torus moves side-to-side in X.

You can create more complex expressions using multiple attributes and MEL's math functions.

5 | Nodes and attributes

How do I? > Break connections between attributes

When you type an expression into a text box in the Attribute Editor or Channel Box and press Enter, Maya then shows the computed value with an purple background. You can't edit values that are the result of an expression. To edit the expression, use the Expression Editor.

Related topics

- ❖ "Connect input and output attributes" on page 172
- ❖ "Connect input and output attributes" on page 172
- ❖ "Break connections between attributes" on page 174

Break connections between attributes

Attribute values that are controlled by a connection have an purple background in the Channel Box and Attribute Editor.

Do one of the following:

- In the Channel Box or Attribute Editor, press the right mouse button on the attribute and choose Break Connections.
- Select the connection line (or lines) in the Hypergraph and press Delete.

Related topics

- ❖ "Connect input and output attributes" on page 172
- ❖ "Connect attributes with an expression" on page 173

Set a node's update state

To show the Node State attribute

- 1 Select the node you want to change.
- 2 Show the Attribute Editor (Window > Attribute Editor).
- 3 Expand the Node Behavior section.

To...	Set the Node State attribute to...
Disable the effect of the selected node.	HasNoEffect.
Keep the selected node from updating when its inputs change.	Blocking.

5 | Nodes and attributes

How do I? > Show or hide nodes

To...	Set the Node State attribute to...
Make the node active again.	Normal.

Notes

- The “HasNoEffect” state has a different meaning for each node type. Some node types do not implement the state, in which case the state acts just like “Normal”.
- The “Waiting” node states are used internally by Maya to keep track of nodes that are waiting for a view update in the Hypergraph. You should not normally set nodes to a “Waiting” state.

Change the display of nodes and attributes

Show or hide nodes

To...	Do this
Expand or collapse hierarchy under a node.	<ul style="list-style-type: none">• In the Outliner, click the plus or minus icon to the left of the node name.• In the Hypergraph, double-click the node.
Show auxillary node types.	In an editor, choose Show > Show Auxiliary Nodes.
Control which node types are hidden as auxillary.	<p>In an editor, choose Show > Auxiliary Nodes.</p> <ul style="list-style-type: none">• To remove a node from the hidden list, click it in the top list and click Remove From List.• To add a node to the hidden list, click it in the bottom list and click Add to Hide List.
Show or hide shape nodes in the Hypergraph.	In the Hypergraph, choose Options > Display > Shape Nodes.
Show or hide hidden nodes in the Hypergraph.	In the Hypergraph, choose Options > Display > Hidden Nodes.

5 | Nodes and attributes

How do I? > Control which objects or attribute types appear in an editor

To...	Do this
Show or hide underworld nodes in the Hypergraph.	In the Hypergraph, choose Options > Display > Underworld Nodes. Underworld nodes are only visible if shape nodes are also visible.

Related topics

- ❖ "View and edit the hierarchy of nodes" on page 168
- ❖ "Show inputs and outputs (dependency graph)" on page 171

Control which objects or attribute types appear in an editor

The Outliner, Hypergraph, Graph Editor, Dope Sheet, and Relationship Editor let filter out information you're not interested in right now.

To temporarily filter out objects or attributes from the editor display

To...	Do this
Only show items with specific text in their names.	Type text in the text filter box and press Enter. An asterisk (*) matches anything. A question mark (?) matches any single character. For example, to show all items whose name starts with <code>spot</code> , type <code>spot*</code> in the text filter box. To show items with <code>new</code> anywhere in their names, type <code>*new*</code> .
Only show certain types of objects.	In the Show > Objects submenu, choose the object types you want to show. To show all object types again, choose Show > Objects > Clear Below.

How do I? > Save and reuse object or attribute visibility filters in editors

To...	Do this
Only show certain types of attributes.	In editors that show attributes (Relationship Editor with characters, Outliner with Display > Attributes on): In the Show > Attributes submenu, choose the object types you want to show. To show all object types again, choose Show > Attributes > Clear Below.
Only show objects or attributes of the same type(s) as the selection.	Choose Show > Show Selected Type(s).
Show all objects and attributes.	Choose Show > Show All.

Related topics

- ❖ "Outliner" on page 185
- ❖ "Hypergraph" on page 202

Save and reuse object or attribute visibility filters in editors

To save an object filter

- 1** Select objects of the type you want to show.
- 2** In the editor, choose Show > Show Selected Type(s).
- 3** Choose Show > Create Entry.
- 4** Type a name for the filter and click Save.
The filter appears in the Show > Objects submenu.

To save an attribute filter

- 1** Select attributes of the type you want to show.
- 2** In the editor, choose Show > Show Selected Type(s).
- 3** Choose Show > Create Entry.
- 4** Type a name for the filter and click Save.
The filter appears in the Show > Attributes submenu.

5 | Nodes and attributes

Reference > Edit > Select Hierarchy

To delete a saved filter

- 1 Choose Show > Delete Entry.
- 2 Click the Objects or Attributes tab.
- 3 Click the name of the filter and click Delete.

Related topics

- ❖ "Outliner" on page 185
- ❖ "Hypergraph" on page 202

Reference **Menus**

Edit

Edit > Select Hierarchy

Selects all nodes under the currently selected node in the scene hierarchy.

Related topics

- ❖ "Scene hierarchy" on page 152

Edit > Parent

Makes the selected nodes children of the last node you selected (the key object). Select the objects you want to assign to the parent, then shift-select the parent and choose Edit > Parent.

Related topics

- ❖ "View and edit the hierarchy of nodes" on page 168
- ❖ "Edit > Unparent" on page 179

Edit > Parent > □

Parent Method

Select what you want done with the selected object:

Move Objects Move the object from its current parent to the new parent (the last selected object).

Add Instance Create an instance under the new group instead of moving the object.

Preserve Position

Turn Preserve Position on to preserve the overall world-space position by changing the parented objects' transformation matrix.

Note If two objects are selected, the first object goes under the second.

Edit > Unparent

Related topics

- ❖ "View and edit the hierarchy of nodes" on page 168
- ❖ "Edit > Parent" on page 178

Edit > Unparent > □

Unparent Method

Select how you want to unparent the selected object:

Parent to World Remove the object from its current parent and place it under the world.

Remove Instance Remove a particular instance instead of moving the object.

Preserve Position

Turn Preserve Position on to preserve overall world-space position by modifying the parented objects' transformation matrix.

Modify

Modify > Evaluate Nodes

The items in this submenu let you turn off evaluation of various animation and modeling nodes to improve performance. The effects of the nodes do not appear in the view panels until you turn them on again.

Modify > Prefix Hierarchy Names

Adds a prefix to the name of the selected parent object and all its children.

- 1 Select the parent.

5 | Nodes and attributes

Reference > Modify > Add Attribute

- 2 Choose Modify > Prefix Hierarchy Names.
- 3 Type a prefix and click OK.

Related topics

- ❖ “Change the name of one or more objects” on page 224

Modify > Add Attribute

Custom attributes are attributes you optionally add and define from the Add Attribute window. Although custom attributes are dynamically added to an object, we refer to them as custom to distinguish them from the built-in dynamic attributes.

Custom attributes have no direct effect on any characteristic of an object in Maya. You can use them to control a combination of other attributes. You might also use a custom attribute as a variable—a place to store a value temporarily to be read by other attributes.

When you add a custom attribute to an object, it appears in the Extra Attributes section of the Attribute Editor (and in the Channel Box, if you make the attribute keyable).

Related topics

- ❖ “Create, edit, or delete custom attributes” on page 166

Options

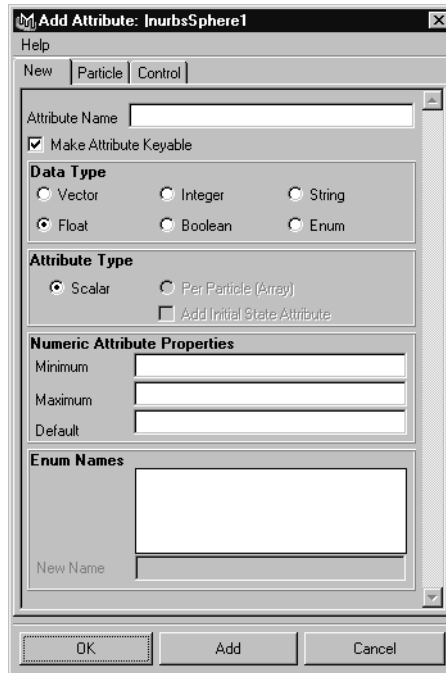

Attribute Name

Type the name of the attribute you are adding.

Make Attribute Keyable

Turn this option on to make this attribute keyable. For information about keyable attributes, see Animation.

Data Type

Select the data type for the attribute:

- | | |
|---------|---|
| Vector | Creates a vector attribute consisting of three floating point values. |
| Float | Creates a floating point attribute. |
| Integer | Creates an integer attribute. |
| Boolean | Creates an attribute consisting of an on/off turn. |
| String | Creates a string attribute that accepts alphanumeric entries as data entry, such as a filename. |
| Enum | Creates an attribute that accepts selections from an “enumerated” or drop-down list. |

5 | Nodes and attributes

Reference > Modify > Add Attribute

Note If you select Float or Integer, you can also set Numeric Attribute Properties.

Attribute Type

Select a type:

- | | |
|-----------------------------|---|
| Scalar | Creates a per object attribute that you can set to a single value that applies to every particle in the object. A vector scalar is considered a single value with three numbers. If you select Scalar, you can specify Minimum, Maximum, and Default values for a Float or Integer attribute. |
| Per Particle (Array) | Creates a per particle attribute. You can set this type of attribute to different values for each particle. If you select Per Particle (Array), you can also create a counterpart initial state attribute by turning on Add Initial State Attribute. |
| Add Initial State Attribute | Turn on to create a corresponding initial state attribute for the added attribute. Without this corresponding attribute, you can't save a particle object's current attribute values for initial state usage. You must write a creation expression if you decide to initialize the custom attribute's value upon rewinding the animation. If you know you're going to write a creation expression for a custom attribute, you can set Add Initial State Attribute to off when you add the attribute. Otherwise, set Add Initial State Attribute to on whenever you add a custom per particle attribute. |

Numeric Attribute Properties

For scalar attributes, Minimum and Maximum set the lowest and highest values you can enter for the attribute in the Attribute Editor or Channel Box. Default sets the default value for the attribute.

Enum Names

When you're adding a new Enum attribute, you need to define the list of acceptable strings. There are two default strings, "Green" and "Blue", in the Enum Names list that you can change. To change, select

5 | Nodes and attributes

Reference > Modify > Add Attribute

Green or Blue and then enter the new string in the *New Name* text box. To add a new string, click the blank entry below the last list item and type the string in the New Name text box.

The following list of names are reserved internally for (dynamic) shading attributes. You may use these names for custom attributes, but beware they may produce unexpected results in the shading network. For example, during shading the uvCoord value is provided, therefore ignoring your custom uvCoord attribute value.

blobbySurfaceFactor
displacement
easMask
farPointCamera
farPointObj
farPointWorld
filterSize
flippedNormal
illuminationIndex
infoBits
lightData
lightTable
matrixObjectToWorld
matrixWorldToObject
mediumRefractiveIndex
normalCamera
numShadingSamples
objectId
objectType
opticalDepth
outColor
outGlowColor
outMatteOpacity
outParticleEmission
outTransparency
particleAge
particleAttrArray
particleColor
particleEmission
particleEntryParam
particleExitParam
particleIncandescence
particleLifespan
particleOrder
particleTransparency
particleWeight
pixelCenter

5 | Nodes and attributes

Reference > Modify > Edit Attribute

pixelCoverage
pointCamera
pointObj
pointWorld
primitiveId
rayDepth
rayDirection
rayOrigin
receiveShadows
refPointCamera
refPointObj
refPointWorld
renderState
shadowAttenuation
tangentUCamera
tangentVCamera
translucenceDepth
triangleNormalCamera
uvCoord
uvFilterSize
vertexCameraOne
vertexCameraThree
vertexCameraTwo
vertexUvOne
vertexUvThree
vertexUvTwo

Modify > Edit Attribute

You can edit custom (or *dynamic*) attributes from either the main menu (Modify > Edit Attribute) or from the Attribute Editor (Attributes > Rename Attributes). You can perform the following editing operations on custom attributes.

Related topics

- ❖ “Create, edit, or delete custom attributes” on page 166

Options

- You can rename a custom attribute. Select it in the Attributes list and modify the name in the New Name text box.

In attribute names, all punctuation except for the underscore (_) and the pound sign (#) are illegal characters

5 | Nodes and attributes

Reference > Modify > Delete Attribute

- You can add, remove, or modify minimum and maximum values (for Integer, Float, and Vector type attributes). Select the attribute in the Attributes list and then turn on or off the Has Minimum and Has Maximum checkboxes, as well as type values for these in the corresponding Min/Max text boxes.
- You can control the display of custom attributes in the Channel Box. Select the attribute in the Attributes list and then turn the Keyable check box on or off. When Keyable is turned on, the custom attribute appears in the Channel Box.
- You can change Enum strings. Select the Enum attribute in the Attributes list and modify the strings in the Enum list the same way you created them.

Note You cannot key string attributes.

Note When you create a Vector type custom attribute, three child attributes are created (*nameX*, *nameY*, *nameZ*, where *name* is the name of the attribute).

For example, if you created a vector attribute named Speed, the children would be SpeedX, SpeedY, and SpeedZ. You can't access the Numeric Attribute Properties (Keyable and Min/Max) of the parent vector attribute. You have to select a child attribute and modify its Numeric Attribute Properties.

Modify > Delete Attribute

You can delete custom attributes from the main menu (Modify > Delete Attribute) or from the Attribute Editor (Attributes > Delete Attributes). You cannot delete built-in attributes.

Related topics

- ❖ "Create, edit, or delete custom attributes" on page 166

Windows and Editors

Outliner

The Outliner shows a hierarchical list of all objects in the scene in outline form.

To show the Outliner choose Windows > Outliner.





5 | Nodes and attributes

Reference > Outliner

Related topics

- ❖ "The Outliner" on page 154
- ❖ "View and edit the hierarchy of nodes" on page 168

Outline

To...	Do this
Expand or collapse the level under a node.	Click the square plus  or minus  next to the node's name.
Expand <i>all</i> levels under a node.	Hold Shift and click the square plus  next to the node's name.
Change a node's order in the hierarchy.	Drag the node with the middle mouse button and drop it between two other nodes.
Make a node a child of another node.	Drag the node with the middle mouse button and drop it on top of the node you want to be its parent. If you can't see both nodes at the same time in the Outliner, use Edit > Parent instead.
Bring a node out from under its parent.	Select the child node and choose Edit > Unparent.
Split the Outliner window.	Drag the divider bar at the bottom of the window up. When the pointer is over the bar the cursor changes to a up/down drag indicator  . To unsplit the window, drag the divider back down to the bottom of the window.
Rename a node.	Double-click the node's name. In node names, all punctuation except for the underscore (<code>_</code>) and the pound sign (<code>#</code>) are illegal characters.

To...	Do this
Allow the display of attributes (channels) in the Outliner.	Turn on Display > Attributes (Channels). You can also limit the display of attributes with the Outliner's Show > Attributes sub-menu.
Show or hide the attributes on a node.	Click the round plus (⊕) or minus (⊖) next to the node's name. You can further expand multi-value attributes. You cannot edit attribute values in the Outliner.
Open a node in the Attribute Editor.	Double-click the icon next to the node's name.
Open an attribute in the Expression Editor.	Double-click the attribute name.

Note The Display and Show menu settings are saved with a scene file. The menu settings are not saved when you open a new or different scene.

Menus

Display

DAG Objects Only

Only show transformable nodes.

Shapes

Show shape nodes.

Attributes (Channels)

Allow the display of attributes on nodes. Use the round plus and minus buttons to show a node's attributes.

Set Members

Allow the display of members under the sets.

5 | Nodes and attributes

Reference > Outliner

Connected

Only show attributes that are connected another node, keyed, or connected by set driven key, a constraint, a motion path, or an expression.

Reveal Selected

Expands the outline to show the currently selected node(s).

Channel Names

Choose what attribute names to show when Attributes (Channels) is on. Nice names are more readable. Long and Short names are the actual names of attributes, which you can use in expressions and MEL.

Sort Order

Choose Scene Hierarchy to show the hierarchy. Choose Alphabetical Within Type to show flat alphabetical lists of each node type.

Select Set Members

Selects the members of the highlighted set.

Show

Objects

Choose which object types to show in the Outliner. Choose Clear Below to turn off all filters.

Attributes

Choose which attribute types to show in the Outliner. Choose Clear Below to turn off all filters.

Hidden Hidden attributes.

Keyable Keyable attributes.

Scale, Rotate,
Translate Scale, Rotate, or Translate attributes.

Driven by Anim
Curve Attributes with an animation curve. This includes attributes animated with keys, set driven keys, constraints, and motion paths.

Driven by
Expression Attributes controlled by expressions.

User Defined User-defined attributes.

Invert Shown

Reverse the filters so visible objects are hidden and hidden objects are visible.

Show All

Turns off all filters in the Show menu.

Show Selected Type(s)

Shows only object types of the same type as the current selection.

Create Entry

Lets you save the current filter with a name.

Delete Entry

Lets you delete a saved filter.

Show Auxiliary Nodes

Shows node types that the Outliner normally does not show because they are rarely needed (such as underworld nodes).

Auxiliary Nodes

Lets you set what nodes are considered "auxiliary".

Attribute Editor

Lists attributes on the selected object. Tabs across the top of the Attribute Editor let you select nodes connected to the shown node.

While the Channel Box provides a more compact view of keyable attributes, the Attribute Editor gives you full graphical controls to edit attributes rather than just text boxes.

You can set an option in Window > Settings/Preferences > Preferences to have the Attribute Editor open in a window instead of the side panel.

Related topics

- ❖ "Nodes and attributes" on page 149
- ❖ "Change attribute values in the Attribute Editor or Channel Box" on page 159
- ❖ "Save and reuse attribute presets" on page 164
- ❖ "Lock the value of an attribute" on page 166
- ❖ "Create, edit, or delete custom attributes" on page 166
- ❖ "Open multiple Attribute Editors" on page 167
- ❖ "Channel Box" on page 196

5 | Nodes and attributes

Reference > Attribute Editor

Loading object attributes into the Attribute Editor

Loading attributes into the Attribute Editor makes them available to view or edit. There are three ways to load object attributes into the Attribute Editor:

- automatically when you select the object
- manually
- by selecting the object from the Attribute Editor Selected menu
- by selecting the object from the Focus menu

Loading attributes automatically

When you select an object, its attributes are automatically loaded into the Attribute Editor where you can view and edit them. Each node of the selected object automatically appears as a tab. This is the default method.

To automatically load attributes for selected objects

In the Attribute Editor, select List > Auto Load Selected Attributes to turn it on.

Note If you select more than one item, Maya automatically updates the most recently selected one (that is, the most recent one in the pick list).

Loading attributes manually

If Auto Load Selected Attributes is turned off, after selecting an object, you must manually load the object's attributes into the Attribute Editor to view and edit them.

To manually load attributes for selected objects

- Click the Load Attributes button at the bottom of the Attribute Editor.

Attribute Editor colors

The color of the attribute box changes depending on its state. For more information, see "Channel Box colors" on page 199.

Menus

List

Use this menu to load attributes into the Attribute Editor and to define which items display in the Selected/Object menu.

Selected/Object

The Selected menu lists objects currently selected in the scene while the Object menu displays all the objects in the scene of a selected type.

Focus

This menu displays all nodes that have been selected in the scene while the Attribute Editor is open. The most recently selected node is at the top of the list.

Attributes

Use this menu to add, edit, and delete extra attributes for an object or node. These appear under the Extra Attributes section. You can also add, edit, and delete attributes using the Modify menu.

Context menu

output connection node

If you set a key for the attribute or connect a texture to it, the resulting output connection node name displays as the first menu item. To load the attributes for this node into the Attribute Editor, select it.

Create New Expression

Select this option to create a new expression for the attribute.

Set Key

Select this option to set a key for the attribute. This options disappears from the menu if you have already connected a texture to the attribute.

Set Driven Key

Select this option to link the attribute values.

Break Connection

Select this option to break the connection between the attribute and a key or texture.

Create New Texture

Select this option to connect a texture to the attribute.

Color Chooser

This option displays for color attributes only. Select it to open the Color Chooser.

Lock/Unlock Attribute

Select the Lock option to lock an attribute value so that it cannot be changed. Use Unlock Attribute to unlock the value.

5 | Nodes and attributes

Reference > Attribute Editor

Ignore/Don't Ignore when Rendering

This option displays only for attributes that are connected to keys or textures. Select the Ignore when Rendering option to ignore the connection when rendering. If the attribute has a map button, the button changes to indicate that the connection is ignored.



Indicates that the attribute is connected to a key or texture



Indicates that the connection is ignored when rendering

Select the Don't Ignore when Rendering option to render with the set connection. For details, see Rendering.

Attributes > Add Attributes

New tab

Attribute Name

Type the name of the attribute you are adding.

Make Attribute Keyable

Turn this option on to make this attribute keyable. For information about keyable attributes, see Animation.

Data Type

Select the data type for the attribute:

Vector	Creates a vector attribute consisting of three floating point values.
Float	Creates a floating point attribute.
Integer	Creates an integer attribute.
Boolean	Creates an attribute consisting of an on/off turn.
String	Creates a string attribute that accepts alphanumeric entries as data entry, such as a filename.
Enum	Creates an attribute that accepts selections from an "enumerated" or drop-down list.

Note If you select Float or Integer, you can also set Numeric Attribute Properties.

Attribute Type

Select a type:

Scalar	Creates a per object attribute that you can set to a single value that applies to every particle in the object. A vector scalar is considered a single value with three numbers. If you select Scalar, you can specify Minimum, Maximum, and Default values for a Float or Integer attribute.
Per Particle (Array)	Creates a per particle attribute. You can set this type of attribute to different values for each particle. If you select Per Particle (Array), you can also create a counterpart initial state attribute by turning on Add Initial State Attribute.
Add Initial State Attribute	Turn on to create a corresponding initial state attribute for the added attribute. Without this corresponding attribute, you can't save a particle object's current attribute values for initial state usage. You must write a creation expression if you decide to initialize the custom attribute's value upon rewinding the animation. If you know you're going to write a creation expression for a custom attribute, you can set Add Initial State Attribute to off when you add the attribute. Otherwise, set Add Initial State Attribute to on whenever you add a custom per particle attribute.

Numeric Attribute Properties

For scalar attributes, Minimum and Maximum set the lowest and highest values you can enter for the attribute in the Attribute Editor or Channel Box. Default sets the default value for the attribute.

Enum Names

When you're adding a new Enum attribute, you need to define the list of acceptable strings. There are two default strings, "Green" and "Blue", in the Enum Names list that you can change. To change, select Green or Blue and then enter the new string in the *New Name* text box. To add a new string, click the blank entry below the last list item and type the string in the New Name text box.

Warning!The following list of names are reserved internally for (dynamic) shading attributes. You may use these names for custom attributes, but beware they may produce unexpected results in the shading network. For example, during shading the uvCoord value is provided, therefore ignoring your custom uvCoord attribute value.

5 | Nodes and attributes

Reference > Attribute Editor

blobbySurfaceFactor
displacement
easMask
farPointCamera
farPointObj
farPointWorld
filterSize
flippedNormal
illuminationIndex
infoBits
lightData
lightTable
matrixObjectToWorld
matrixWorldToObject
mediumRefractiveIndex
normalCamera
numShadingSamples
objectId
objectType
opticalDepth
outColor
outGlowColor
outMatteOpacity
outParticleEmission
outTransparency
particleAge
particleAttrArray
particleColor
particleEmission
particleEntryParam
particleExitParam
particleIncandescence
particleLifespan
particleOrder
particleTransparency
particleWeight
pixelCenter
pixelCoverage
pointCamera
pointObj
pointWorld
primitiveId
rayDepth
rayDirection
rayOrigin
receiveShadows

refPointCamera
refPointObj
refPointWorld
renderState
shadowAttenuation
tangentUCamera
tangentVCamera
translucenceDepth
triangleNormalCamera
uvCoord
uvFilterSize
vertexCameraOne
vertexCameraThree
vertexCameraTwo
vertexUvOne
vertexUvThree
vertexUvTwo

Attribute Spread Sheet

Lists multiple attributes on multiple objects in a spreadsheet format.

Related topics

❖ “View and edit multiple attributes on multiple nodes” on page 162

Menus

Names

Names > Short Attribute Names, Long Attribute Names

Choose whether to show the short or long attribute names at the tops of the columns.

Layouts

Layouts > Show Selected Columns Only/Show All Columns

Hides the attribute columns that are not currently selected. Choose Show All Columns to return to the full display.

Layouts > Remember This Layout

Creates a new tab with only the currently visible attribute columns. Select the columns you want in the new tab, choose Show Selected Columns, then Remember This Layout.

5 | Nodes and attributes

Reference > Channel Box

Layouts > Delete This Layout

Deletes a custom tab created with Remember This Layout. Click the tab and choose Delete This Layout to delete the tab.

Key

Key > Key Selected

Sets keys at the current frame for the attributes (cells) currently selected in the spreadsheet.

Tabs

The different tabs show different types of attributes.

Use the arrows at the right end of the tabs to show more tabs that are hidden by the window's edge.

Use Layouts > Show Selected Columns Only and Layouts > Remember This Layout to create a new custom tab with only the attributes you want.

Spreadsheet

- Each object is a row, and each attribute on the object is a column.
- Click, shift-click, or drag across a cell, column, or row to select it.
- Type a value to enter it in all selected cells.

Channel Box

The Channel Box is the primary, fastest, and most streamlined tool for editing object attributes. It lets you quickly set keys, and lock, unlock, or create expressions on attributes.

5 | Nodes and attributes

Reference > Channel Box

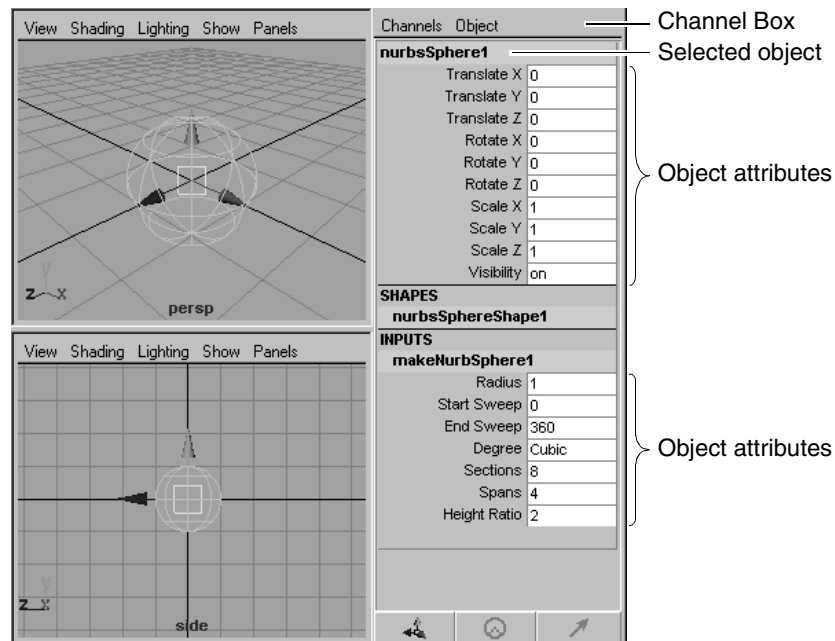

Like the Attribute Editor, you use the Channel Box to modify an object's attribute values. The Channel Box is different from the Attribute Editor in the following ways:

- It displays only the keyable attributes for the selected object. (You can make an object keyable, and therefore display in the Channel Box by selecting Window > General Editors > Channel Control.
- You can change multiple attribute values of multiple objects (see "View and edit multiple attributes on multiple nodes" on page 162)
- It takes up much less space in the window.
- You can control construction history.

The information displayed in the Channel Box varies, depending on what kind of object or component you have selected. If you haven't selected an object, the Channel Box is blank.

Related topics

- ❖ "Nodes and attributes" on page 149
- ❖ "Change attribute values in the Attribute Editor or Channel Box" on page 159
- ❖ "Show or hide the manipulator for an attribute in the Channel Box" on page 161
- ❖ "Lock the value of an attribute" on page 166

5 | Nodes and attributes

Reference > Channel Box

- ❖ “Create, edit, or delete custom attributes” on page 166
- ❖ “Control the display of attributes in the Channel Box” on page 167
- ❖ “Connect attributes with an expression” on page 173

Showing the Channel Box

The Channel Box appears in the sidebar when you select Display > UI Elements > Channel Box/Layer Editor, or click the Channel Box/Layer Editor icon  in the toolbar.

You can display either the Channel Box or the Attribute Editor in the sidebar, but not both.

Use the Channel Box toolbar to control the display of the Channel Box and Layer Editor.

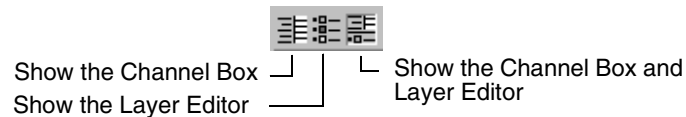

You can resize the Channel Box using the arrow buttons at the bottom of the Channel Box / Layer Editor.

Click  to widen the Channel Box. Click  to narrow the Channel Box.

Attributes

When you select a geometric object, the Channel Box displays these sections:

Section	Usage
<i>objectName</i>	Lists the keyable transform attributes that translate, scale, and rotate the object’s absolute position in the world space. Also shows the object’s visibility attribute.
SHAPES	Lists the names of nodes that define the geometry of the object. Other nodes, such as related particle emitters may be found here.
INPUTS	Lists the names of other nodes that affect this one. Typically, these comprise the “construction history” of the node.
OUTPUTS	Lists the names of the output nodes (nodes that receive data) for this node.

5 | Nodes and attributes

Reference > Channel Box

If you've selected two or more objects, the Channel Box displays the attributes for the last object selected only. To display the attributes in the Channel Box of another selected object, select **Object > *objectName***.

Edits you make in the Channel Box affect **all selected objects** of the same type as the one displayed.

Component attributes

If you display attributes of an object component, the Channel Box displays only one section for shape attributes that pertain to the component.

For example, suppose you've created a NURBS curve with the following CVs:

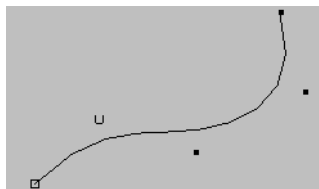

If you turn on component selection mode (in the main menu bar) and select the CVs, the Channel Box displays this:

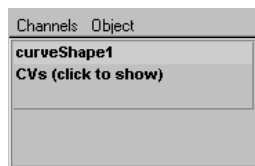

You can display the CV values in the Channel Box and enter new values. To display the values, click **CVs (click to show)** in the Channel Box.

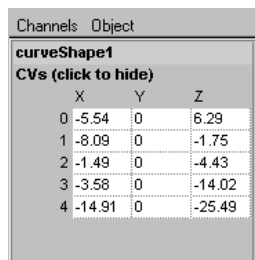

Channel Box colors

The following colors represent the state of channels in the Channel Box:

5 | Nodes and attributes

Reference > Channel Box

State	Color
Locked	<ul style="list-style-type: none">• Gray (Windows, IRIX, and Linux)• Pink (Mac OS X)
Muted	Brown
Blended	Green
Keyed	Light Orange
Expression	Purple
Constrained	Blue
Connected	Yellow

Setting keys in the Channel Box

To set a key for one attribute

- 1 Select the object.
- 2 Click the timeline frame number where you want to set the key.

Click the timeline

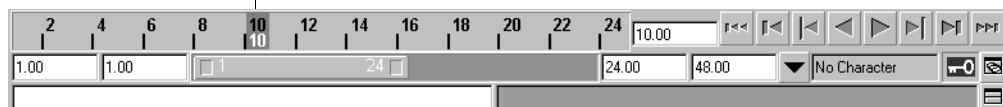

- 3 Click the attribute name to select it.
For example, click Translate X.
- 4 Type the value of the attribute and press Enter.
For example, enter 10 and press Enter.
- 5 In the Channel Box, choose Channels > Key Selected.
or
Press the right mouse button on the attribute name or text box and select Key Selected.
This sets the key for the object attribute value you specified.

Setting a key for all attributes

- 1 Click the timeline frame number where you want to set the key.

2 Enter values for the desired attributes in the Channel Box. Press Enter after entering the attributes.

3 In the Channel Box, select Channels > Key All.

or

Press the right mouse button on the attribute name or text box and select Key All.

This sets the key for all the object attribute values displayed in the Channel Box.

You can key the same attribute value for two or more objects. Select the objects, click the frame, enter the value in the text box, then select Channels > Key Selected.

You can also key multiple attribute values for multiple objects. Follow the instructions in the previous paragraph, only select several attribute text boxes using Ctrl- or Shift-click before typing the numerical entry.

To copy keyed attribute values

1 Select the object.

2 In the Channel Box, select the desired attributes. (You can select either the attribute name, or the attribute text boxes.)

3 Select Channels > Copy Selected.

or

Press the right mouse button on the attribute name or text box and select Copy Selected.

4 Select the attributes you want to paste the keyframed values to.

5 Select Channels > Paste Selected.

or

Press the right mouse button on the attribute name or text box and select Paste Selected.

Breakdowns are a type of key that maintains a proportional relationship with adjacent keys. You can set a breakdown key for an attribute from the Channel Box.

To set a breakdown for selected attributes

1 Select the object.

2 Click the timeline frame number where you want to set the breakdown.

3 Select the attributes you want to set breakdowns for.

4 Enter the values of the attributes.

5 | Nodes and attributes

Reference > Hypergraph

5 Select Channels > Breakdown Selected.

or

Press the right mouse button on the attribute name or text box and select Breakdown Selected.

To set breakdowns for all attributes

1 Select the object.

2 Click the timeline frame number where you want to set the breakdowns.

3 Enter the values of the attributes.

4 In the Channel Box, select Channels > Breakdown All.

or

Press the right mouse button on the attribute name or text box and select Breakdown All.

INPUTS

Use the INPUTS component of the Channel Box to modify an object's construction history.

Hypergraph

Hypergraph

Presents a graphical view of the scene hierarchy or dependency graph, with box representing nodes and lines representing relationships.

Related topics

- ❖ "The Hypergraph" on page 155
- ❖ "View and edit the hierarchy of nodes" on page 168
- ❖ "Change the order of nodes" on page 171
- ❖ "Change the visual layout of nodes in the Hypergraph" on page 170
- ❖ "Show inputs and outputs (dependency graph)" on page 171
- ❖ "Connect input and output attributes" on page 172
- ❖ "Connect attributes with an expression" on page 173
- ❖ "Break connections between attributes" on page 174
- ❖ "Show or hide nodes" on page 175

Graph area

Use the camera move keys (alt + the middle mouse button and alt + the right mouse button) to move around the graph the same way you move around in view panels.

Edit > Expand, Collapse, Expand All, Show Selected

Edit > Expand to expand a node to one level below.

Edit > Expand All to expand all subnodes below a node.

Edit > Show Selected to display and expand a node not visible in the graph.

Options > Display > Shape Nodes, Hidden Nodes, Underworld Nodes

By default, the scene hierarchy does not display shape nodes, hidden nodes, or underworld nodes. It displays only transform nodes—nodes that hold attributes and other information on an object's transformation and parent-child relationships.

Shape node—holds an object's geometry attributes or attributes other than the object's transform node attributes. A shape node is a child of a transform node. A transform node has only one shape node.

Hidden node—any object hidden using Display > Hide from Maya's menu bar. The default cameras top, front, side, and persp are also hidden nodes.

Underworld node—a pair of nodes below a shape node. When you create a curve on a NURBS surface, Maya generates an underworld transform node and shape node below the shape node of the surface. The CV positions of underworld nodes have UV coordinates on the surface rather than coordinates in world or local space.

A dotted line in the scene hierarchy indicates a connection to an underworld node. Connections to instanced objects are also indicated by dotted lines.

Note Hypergraph option settings are saved with a scene file. The options are not saved for Maya globally.

Example

If you select Create > NURBS Primitives > Sphere to create a sphere, Maya creates a transform node and a shape node.

5 | Nodes and attributes

Reference > Hypergraph

The sphere's shape node holds the mathematical description of the sphere's shape. The sphere's transform node holds the sphere's position, scaling, rotation, and so on. The shape node is the child of the transform node.

If you select Options > Display > Shape Nodes in the Hypergraph, the scene hierarchy shows these nodes for the sphere:

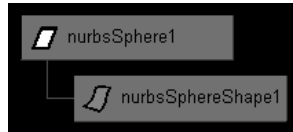

Maya gives the nodes the default names shown in the preceding figure. The transform node is nurbsSphere1, the shape node is nurbsSphereShape1. If you rename the transform node, for example, to Bubble, Maya renames the shape node to BubbleShape.

If you rename the shape node, Maya does not rename the transform node. Maya doesn't transmit a child's attribute changes up to its parent.

Example

If you select Create > NURBS Primitives > Sphere to create a sphere, Maya creates a transform node and a sphere node. If you then select Modify > Make Live, then use the Create > CV Curve Tool to draw a curve on the surface of the sphere and turn on the display of shape nodes and underworld nodes, the scene hierarchy appears as follows:

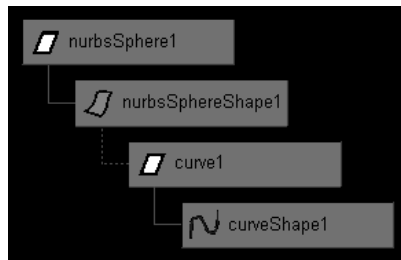

Maya gives the nodes the default names shown. The transform node is nurbsSphere1, the shape node is nurbsSphereShape1. The curve1 and curveShape1 nodes are underworld nodes for the curve created on the sphere's surface.

When a curve-on-surface is hard to select in the workspace because of crowding or complex geometry, you can select it easily in the scene hierarchy with underworld nodes displayed.

Options > Display > Expression Connections, Constraint Connections, Deformer Connections

You can display color-coded lines in the scene hierarchy that illustrate nodes connected by an expression, constraint, or deformer.

Example

You create a NURBS sphere named Ball and a NURBS cone named Cone. You write an expression to assign the value of Ball's translateY attribute to Cone's translateY attribute. The expression links the two values. When you move Ball up or down in the view (in a Y-axis direction), Cone moves up or down the same amount.

If you select Options > Display > Expression Connections, the scene hierarchy displays this:

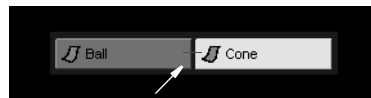

This red line means attributes in the two nodes are connected, for instance, by an expression.

Tip You can change the color-coding of the connection lines and other important entities by selecting Window > Settings/Preferences > Colors from Maya's main menu bar and expanding Hypergraph/Hypershade.

Rendering > Show ShadingGroups, Show Materials, Show Textures, Show Lights

You can show connections to shading groups, materials, textures, and lights. See Rendering for details.

Example

Suppose you create a NURBS sphere, then use the Hypershade to create and assign a Phong shading group to it. Next you use the Hypershade to create a 2D checker texture and assign it to the Phong node.

The Hypershade displays the following contents:

5 | Nodes and attributes

Reference > Hypergraph

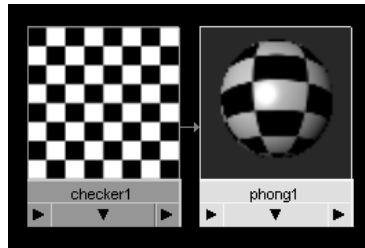

The following dependency graph appears when you select Rendering > Show Shading Groups in the Hypergraph.

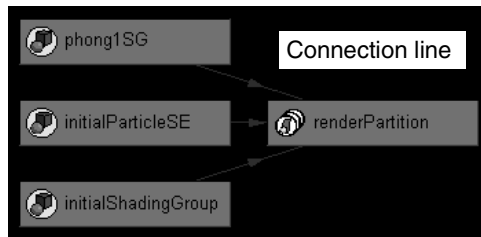

The connection lines between nodes show connection direction. The connection line originates at a node that outputs data, and the line points to a node receiving the data as input. The example above shows that the flow of output goes from the phong1SG shading group to the renderPartition.

Although you can see most of the same nodes in the Hypershade, the dependency graph shows the nodes in a flow diagram. This makes it easy to see the connections between the nodes that make up a shading group.

If you glide the mouse pointer over a connection line, small white boxes appear next to the input node and output node. The white box next to an input node shows the node's name and attribute that receives the input.

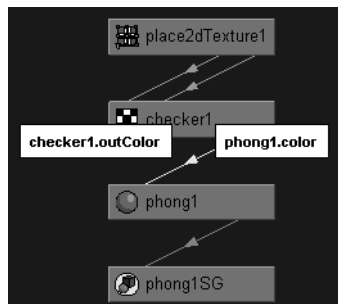

Note—This graph is shown vertically. By default, a dependency graph displays horizontally.

The white box next to an output node shows the node's name and attribute that provides the output. Each node name and attribute is separated by a period, for example, checker1.outColor and phong1.color. In the preceding figure, the outColor attribute of checker1 is output to the color attribute of phong1.

In many cases, you must be familiar with Maya internal operation details to understand the node and attribute names you see in the white boxes.

Graph > Input and Output Connections, Input Connections, Output Connections

You can show Input and Output connections to a selected node. An Input connection is a node that provides input to the selected node. A Output connection is a node that receives input from the selected node.

To see connections to most objects, you must select the shape node of the object rather than the transform node.

provide input to each other all the way to the selected node.

When you display output connections for a node, you see the chain of nodes that output to each other, all the way through to the end receiving node.

Example

You create a wine glass surface by revolving a NURBS curve. The following dependency graph appears when you select the revolved surface's shape node and select Graph > Input and Output Connections:

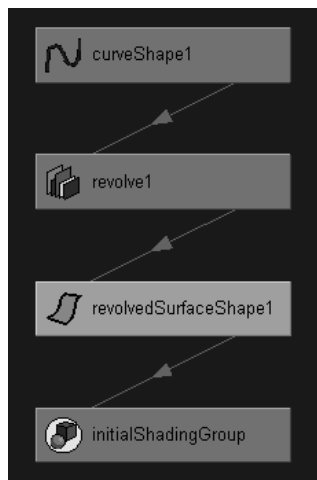

Note—This graph is shown vertically. By default, a dependency graph displays horizontally.

5 | Nodes and attributes

Reference > Hypergraph

The connection lines between nodes show connection direction. The connection line originates at a node that outputs data, and the line points to a node receiving the data as input.

The example graph shows that a curve provides input to the revolve operation node. The revolve operation generates a revolved shape—the wine glass. The revolved shape is connected to `initialShadingGroup`, which sets the default color of all geometric shapes created in Maya.

If you move your mouse pointer over a connection line, small white boxes appear next to the input node and output node. The white box next to an input node shows the node's name and attribute that receives the input.

The white box next to an output node shows the node's name and attribute that provides the output. Each node name and attribute is separated by a period.

In many cases, you must be familiar with Maya's internal operation details to understand the node and attribute names you see in the white boxes.

Note The dependency graph and scene hierarchy display animated nodes as slanted boxes. If you animate a node with an expression, it displays a regular rectangle rather than a slanted box. All other animation techniques display a slanted box. Specifically, a slanted box indicates Ball has a param curve connected to it.

Example

You keyframe the `translateX` attribute of a NURBS sphere named Ball. If you select Ball's transform node and display all input and output connections, this graph appears:



The slanted box indicates Ball's transform node has been animated. The graph doesn't indicate which type of animation technique controls the attribute.

Connection line colors

The connection lines are color-coded to indicate the type of attribute that is connecting the nodes. In this case, attribute types are single, double, triple, data, and array. See the following table for an explanation.

Default Color	Attribute Type	Example Attributes
Blue	Single	transform.translateX, makeNurbsSphere.radius
Cyan	Double	file.repeatUV, cameraShape.cameraAperature
Green	Triple	transform.translate, lambert.color
Magenta	Data	nurbsSurface.create, makeNurbsSphere.outputSurface
Red	Array	particleShape.position, particleShape.velocity

You can change these default colors in the Colors window (Window > Settings/Preferences > Colors).

Tip A dotted line in the scene hierarchy indicates a connection to an underworld node or an instanced object.

Graph > Rebuild

If your scene hierarchy or dependency graph doesn't seem up to date, you can rebuild the graphs. For example, if you add an object to a scene and it doesn't appear in the scene hierarchy, rebuild the graphs to make the scene hierarchy aware of the object's presence.

Options > Transitions > Animate Transitions, 5/10/15/20 frames

When you change the panel view of a graph, for example, by selecting View > Previous View, Maya dollies from one view to another instantaneously, by default. You can slow Maya's transition speed between views to make the view change action easier to see.

20 Frames dollies slowest, 5 Frames dollies fastest.

5 | Nodes and attributes

Reference > Hypergraph tips

Options > Update > On Nodes Creation, On Selection

Whenever you add or delete an object, rendering node, or other item in the scene, the Hypergraph updates the scene hierarchy and dependency graph, by default.

When you select an object in the scene hierarchy or dependency graph, the object is also selected in the workspace, Outliner, and elsewhere in Maya. Also, when you select an object in the workspace, Outliner, and elsewhere in Maya, the object becomes selected in the scene hierarchy or dependency graph.

These updates slow Maya operation when you work with a complex scene or when you're examining nodes or dragging nodes to new positions in a free-form hierarchy. You can turn off updating to improve operation speed.

Hypergraph tips

Use the following tips to define an easier and faster workflow when using the Hypergraph.

Upstream and downstream connections

To show a shape's upstream and downstream connections, select it before you go to the DG view. It is not enough to select the transform parent.

Selecting multiple nodes

If you select multiple nodes in the DAG view, the DG graph containing all selected nodes is displayed when you go to the DG view.

Free-form layout mode

In free-form layout mode, Maya saves layout information for any node you directly drag or for a collection of nodes that you select and drag.

DG node display

The node type for a given DG node is displayed in the pop-up window only during mouse-over feedback.

Connection lines in the DAG view

Connection lines in the DAG view may clip when you scroll one node out of view. (This includes DG connections and IK handle joint span lines.)

Improve performance when viewing large graphs

To improve performance when viewing large graphs, DAG connections are not drawn while the view changes.

Hypergraph limitations

The following limitations and workarounds relate to the Hypergraph.

Hiding or collapsing shapes in the Hypergraph

A transform node displays the icon of its child shape when you hide or collapse the shape. Depending on the order the graph was built in, the icon may still occasionally show the transform icon, even if it has a shape child.

Workaround

Use Graph > Rebuild to update the icon.

Changing default Hypergraph colors

If you change the default Hypergraph colors (Options > Customize UI > Colors), some objects may lack contrast or appear to be invisible.

Workaround

Select colors that contrast with the background or foreground colors.

Deleting connections in the DG view of the Hypergraph

Connections in the DG view can be deleted only when you single-select them. You cannot delete a multiple selection of connections with a single delete action.

Workaround

Delete each connection individually while you are in the DG view.

Using the IK Handle Tool in the Hypergraph

The IK Handle Tool behaves differently in the Hypergraph than it does in a model view. In a model view you can select the start joint and then select the end joint to add an IK handle. However, in the Hypergraph after you select the first joint you must hold down the Shift key to extend the selection for the end joint.

5 | Nodes and attributes

Reference > Hypergraph limitations

6 Files and organization

About Files and organization

Organizing objects

Groups

A group is a way to transform multiple objects at once. The group shares a single pivot point for rotation and scaling.

In terms of the scene hierarchy, grouping objects together moves them under a new transformation node.

Display layers

Layers are a way of grouping large pieces of the scene together so you can show, hide, or edit them all at once.

Related topics

- ❖ “Scene hierarchy” on page 152
- ❖ “Organize objects on display layers” on page 226

Sets and partitions

Sets

A *set* is a collection of objects or components. Any item you can select can be in a set. The set exists as a separate object representing the collection. Unlike groups, sets do not alter the hierarchy of the scene.

In some instances, Maya creates sets for you as you work with objects. For example, when you add a cluster deformer to some CVs of a NURBS surface, Maya makes a set for the CVs. You can edit the set to control the effect of the deformation. Maya also creates sets that represent shading groups and layers, and points controlled by deformers, flexors, and skin.

You can create a custom set so you can work on its items with a single action. For example, you can create a set of NURBS objects, then hide or display the set as a single entity.

You can control the membership of sets easily using the Relationship Editor.

Sets are useful for the following:

6 | Files and organization

About > File referencing

- Simplifying selection of objects or components that you regularly select or have difficulty selecting in the workspace.
- Assigning objects to shading groups for rendering.
- Moving objects from one layer to another.
- Adjusting deformer, skin, and flexor deformation.
- Adjusting the weight of cluster, cluster flexor, and skin points.
- Working with shading groups.

Partitions

A partition is a collection of related sets. Partitions prevent the sets in them from having any overlapping members. Maya uses partitions to keep sets separate where overlapping members could cause problems.

Maya creates partitions to keep character sets, shading groups, skin point sets, and exclusive deformers from having overlapping members.

You can create your own partitions when you want to create sets that have no overlap.

For example, suppose you're animating a cartoon character's nose as he smiles and laughs. You added a cluster to several CVs for adjusting the nose as he smiles and another cluster to different CVs for adjusting the nose as he laughs.

Creating the two clusters creates a set for each group of CVs. Occasionally you want to move CVs from one set to the other. When you move the CVs from one set to the other set, they remain in the first set. You might not want the CVs in the first set because they add undesirable deformations as you transform the cluster.

To avoid this problem, you can create a partition and put both sets in it. The partition prevents one set from having members of another set. When you move the CVs from the first set to the second set, they're automatically removed from the first set.

Related topics

- ❖ "Create and edit sets" on page 228
- ❖ "Keep a collection of sets from having overlapping membership" on page 228

File referencing

File referencing is a very powerful tool to help organize complex scenes and manage a production process. Within a Maya scene, you can create references to other Maya scenes and objects within those scenes. These

referenced files can be the end product of an entirely separate production process; for example, one group of animators creates and works on the mesh file, which is referenced into the rig file, which is referenced into the shot file.

A technical director create a rigged character used for all the shots; that master rig is then used for various animations. Any issues with the rigged character can then be fixed once, rather than having to re-import the model into many different scenes.

Note Any connections added to a file that is used as a reference will take precedence over connections made in the referencing file. To restore the connections in the referencing file, the referenced connections must be broken, and the attributes reconnected in the referencing file. For example, if animation is added to a file after it is referenced, any animation on those attributes in the referencing file will no longer be displayed. As a general rule, you should try to avoid changes of this type once a file has been referenced.

Related topics

- ❖ "Import or reference data in an external file" on page 220
- ❖ "Reference Editor" on page 253
- ❖ "Preload Reference Editor" on page 255

Supported file formats

Translators

Translators are plug-ins that let you open and/or save data in a given file format. You must have the proper translator plug-in loaded to be able to open, save, import, or export data in the format.

Use the plug-in manager to load or unload translators.

The following lists general file format support. There may be slight differences in support between platforms and depending on variations in file formats. For example, TIFF is a very loosely defined format. It may be possible to save TIFF files in another program that Maya cannot open.

Data Import	Windows	Mac OS X	IRIX	Linux
Maya ASCII	Yes	Yes	Yes	Yes

6 | Files and organization

About > Supported file formats

Data Import	Windows	Mac OS X	IRIX	Linux
Maya Binary	Yes	Yes	Yes	Yes
MEL	Yes	Yes	Yes	Yes
DXF	Yes	Yes	Yes	Yes
DWG	Yes	Yes	Yes	Yes
OBJ	Yes	Yes	Yes	Yes
IGES	Yes	Yes	Yes	Yes
StudioTools wire	Yes		Yes	Yes
AIFF	Yes	Yes	Yes	Yes
image	Yes	Yes	Yes	Yes
mov (ascii motion)	Yes	Yes	Yes	Yes
VRML2	Yes	*	*	*
EPS	Yes	Yes	Yes	Yes
Illustrator	Yes	Yes	Yes	Yes
OpenFlight	Yes	Yes	Yes	Yes
STL	Yes	Yes	Yes	Yes

Data Export	Windows	Mac OS X	IRIX	Linux
Maya Ascii	Yes	Yes	Yes	Yes
Maya Binary	Yes	Yes	Yes	Yes
MEL	Yes	Yes	Yes	Yes
DXF	Yes	Yes	Yes	Yes
OBJ	Yes	Yes	Yes	Yes
IGES	Yes	Yes	Yes	Yes
StudioTools wire	Yes		Yes	

6 | Files and organization
 About > Supported file formats

Data Export	Windows	Mac OS X	IRIX	Linux
mov (ascii motion)	Yes	Yes	Yes	Yes
VRML2	Yes	Yes	Yes	Yes
GE2	Yes	Yes	Yes	Yes
RTG	Yes	Yes	Yes	Yes
mental ray	Yes	Yes	Yes	Yes
RIB	Yes		Yes	Yes
Open Inventor2	Yes	Yes	Yes	Yes
OpenFlight	Yes	Yes	Yes	Yes
Shockwave3D	Yes			

Image Input	Windows	Mac OS X	IRIX	Linux
Maya IFF	Yes	Yes	Yes	Yes
AVI	Yes			
Quicktime		Yes	Yes	
GIF	Yes		Yes	Yes
Softimage	Yes		Yes	Yes
Wavefront RLA	Yes		Yes	
BMP	Yes	Yes		Yes
TIFF	Yes	Yes	Yes	Yes
SGI RGB	Yes	Yes	Yes	Yes
Alias Pix	Yes		Yes	Yes
JPEG	Yes	Yes	Yes	Yes
EPS	Yes			
Cineon	Yes		Yes	Yes

6 | Files and organization

About > Supported file formats

Image Input	Windows	Mac OS X	IRIX	Linux
Quantel	Yes		Yes	Yes
Targa	Yes	Yes	Yes	Yes
MacPaint		Yes		
PhotoShop		Yes		
PNG		Yes		
QuickDraw		Yes		

Image Output	Windows	Mac OS X	Irix	Linux
Maya IFF	Yes	Yes	Yes	Yes
AVI	Yes		Yes	
Quicktime		Yes	Yes	
GIF	Yes		Yes	Yes
Softimage	Yes		Yes	Yes
Wavefront RLA	Yes	Yes	Yes	
BMP	Yes	Yes	Yes	Yes
TIFF	Yes	Yes	Yes	Yes
SGI RGB	Yes	Yes	Yes	Yes
Alias Pix	Yes		Yes	Yes
JPEG	Yes	Yes	Yes	Yes
EPS	Yes		Yes	Yes
Cineon	Yes		Yes	Yes
Quantel	Yes		Yes	Yes
Targa	Yes		Yes	Yes
MacPaint		Yes		

6 | Files and organization

How do I? > Create, open, or save a scene file

Image Output	Windows	Mac OS X	Irix	Linux
PhotoShop		Yes		
PNG	Yes	Yes	Yes	Yes
QuickDraw		Yes		
DDS	Yes	Yes	Yes	Yes

* via wrl2ma

How do I? Work with files

Create, open, or save a scene file

To start a new, blank scene file

- Choose File > New Scene.

You can choose to always create new scenes with default content by choosing File > New Scene > and turning on Enable Default Scene.

To open an existing scene file

- Choose File > Open Scene.

The Open dialog box appears, open in the scene folder of the current project.

To save the current scene file

- To save the scene with its current name, choose File > Save Scene.
- To save the scene with a new name, choose File > Save Scene As.
- To change how Maya saves the scene, choose File > Save Scene > and set the options.

When you use Save Scene As you can choose whether to save the file as Maya Binary (smaller) or Maya ASCII (human readable). To save in a different format, use File > Export All.

Related topics

- ❖ "Translators" on page 215

6 | Files and organization

How do I? > Import or reference data in an external file

- ❖ "Supported file formats" on page 215
- ❖ "Import or reference data in an external file" on page 220
- ❖ "Export objects to a new file" on page 222
- ❖ "Optimize scene size" on page 222

Import or reference data in an external file

To...	Do this
Import data from a file into the scene.	Choose File > Import. To set file format import options, click the file in the Import dialog box and then click Options.
Reference the contents of a file.	Choose File > Create Reference.
Open the Reference Editor.	Choose File > Reference Editor.
Import the contents of a currently referenced file.	In the <i>Reference Editor</i> , click the referenced file and choose File > Import Objects from Reference.
Select the objects that come from a referenced file.	In the <i>Reference Editor</i> , click the referenced file and choose Edit > Select File Contents.
Temporarily load or unload the objects from a referenced file.	In the <i>Reference Editor</i> , click the referenced file and choose Reference > Load Reference or Reference > Unload Reference.
Change the location of a reference.	In the <i>Reference Editor</i> , click the referenced file and choose Reference > Replace Reference. Use the dialog box to find the new location of the file.
Stop referencing a file.	In the <i>Reference Editor</i> , click the referenced file and choose Edit > Remove Reference.

6 | Files and organization

How do I? > Import or reference data in an external file

To...	Do this
Specify which references to load.	Select File > Open > <input type="checkbox"/> and turn on Selective Load. Then click Open and select your file. The Preload Reference Editor appears. In this editor, specify which references to load.
Open a file with no references loaded.	Select File > Open > <input type="checkbox"/> and turn on Load No References. Then click Open and select your file, which is opened with no references loaded.
Create a reference with a locator.	Choose File > Create Reference > <input type="checkbox"/> and make sure the Group and Locator options are turned on, then click Reference.

Referencing limitations

The following operations can cause problems with referenced character sets:

- Removing a member from the character set.
- Deleting a member of the character set.

The animation in the referencing file will be connected to the character but will no longer affect the object. Additionally, if you then add a member to the character, it may or may not take the slot vacated by the previous member, which can cause the referenced file's animation to go to a new object.

- Renaming a member or renaming the character set itself.

This operation is always forbidden when using referencing if the referenced file modifies or connects to the renamed object.

These operations can lead to animation that does not affect the character set or affects the wrong member of the character set.

Related topics

- ❖ "Translators" on page 215
- ❖ "Supported file formats" on page 215
- ❖ "Import or reference data in an external file" on page 220
- ❖ "Export objects to a new file" on page 222
- ❖ "Optimize scene size" on page 222

6 | Files and organization

How do I? > Export objects to a new file

Export objects to a new file

To save scene data in a non-native file format such as OBJ or DXF, you must have a plug-in for that file format loaded.

To...	Do this
Export the selected objects to a file.	Choose File > Export Selection.
Export the scene to a different file format.	Choose File > Export All.
Export the selected objects to a file and then reference it.	Choose File > Reference Editor. In the Reference Editor, choose File > Export Selection as a Reference. Choose the file type from the File of Type drop-down list.

View images or animations

To...	Do this
View an image.	Select File > View Image.
View an animation.	Select File > View Sequence.

A file browser appears and FCheck is launched with the image or animation you specify.

Related topics

❖ *Overview of FCheck*

Optimize scene size

There are several functions available in Maya to decrease the size and complexity of your scene.

6 | Files and organization

How do I? > Organize files into projects

To...	Do this
Remove empty, invalid, and unused information from the scene.	File > Optimize Scene size > <input type="checkbox"/> .
Remove construction history from the selected object(s). Only do this if you are sure you do not need to edit the objects' history again.	Select the objects and choose Edit > Delete by Type > History.
Do not save panel layouts with the scene.	Choose Window > Settings/Preferences > Preferences. Under Misc, turn off Save Panel Layouts with File.
Remove unused file references.	Choose File > Reference Editor. In the Reference Editor, choose File > Clean Up Reference
Delete static animation channels.	Edit > Delete by Type > Static Channels.

Related topics

- ❖ "Construction history" on page 105
- ❖ "Delete" on page 123

Organize files into projects

Maya organizes the various files associated with scene files into *projects*. A project is a collection of folders for different types of files.

To start a new project

- 1 Choose File > Project > New.
- 2 Type the name of the project in the Name text box.
- 3 Click Browse to choose where to save the Project folder.

6 | Files and organization

How do I? > Recover data after a crash

- 4 The Locations text boxes control where Maya looks for files of different types. Click Use Defaults at the bottom of the window to fill in the usual project sub-folder names.

To switch to a different project

- 1 Choose File > Project > Set.
- 2 Choose the top level folder of the project.

To change where the project stores different types of files

- 1 Choose File > Project > Edit Current.
- 2 Edit the paths.

Tips Relative paths start from the project folder.
You can enter multiple paths in a text box by separating them with semicolons (;).

Recover data after a crash

If Maya crashes, it tries to save your scene in Documents/temp in your home folder.

If the TEMP (Windows/Mac OS X) or TMPDIR (IRIX/Linux) variables are set, the recovery file is saved to the path in the variable instead.

Organize and annotate

Organize objects

Change the name of one or more objects

You can give different objects in the scene the same name, but two sibling nodes (nodes with the same parent) cannot have the same name.

Note In node and attribute names, all punctuation except for the underscore (_) and the pound sign (#) are illegal characters.

To change the name of an object or node

Do any of the following:

- Select an object or node and edit its name at the top of the Attribute Editor.

6 | Files and organization

How do I? > Make an object unselectable (template)

- Double-click a node in the Outliner.
- Press the right mouse button on a node in the Hypergraph and choose Rename.

To rename multiple objects at once

- 1 Select the objects.
- 2 Open the pop-up menu next to the input field on the status line and choose Quick Rename.
- 3 Type the base name for all the objects. Maya renames the objects to have the base name plus an incremental number.

To add a prefix to the names of a parent node and all its children

Select the parent node and choose Modify > Prefix Hierarchy Names.

Make an object unselectable (template)

To...	Do this
"Template" an object so it can't be selected.	Select the objects you want to template and choose Display > Object Display > Template.
Make a template object selectable again.	Use the Hypergraph or Outliner to select the templated node and choose Display > Object Display > Untemplate. Templated nodes have a different color in the Hypergraph.
Select a templated object.	Use the Hypergraph or Outliner to select the templated node. or Click the "Select by hierarchy and combinations" icon in the toolbar and set the selection mask to Template.

Related topics

- ❖ "Select objects or components" on page 45
- ❖ "Select a node" on page 48
- ❖ "Select objects based on hierarchy" on page 50

6 | Files and organization

How do I? > Organize objects on display layers

Organize objects on display layers

To...	Do this
Show the Layer Editor.	Choose Display > UI Elements > Channel Box/Layer Editor, or click the Show or hide the Channel Box/Layer Editor button in the toolbar. Set the pop-up menu to Display.
Create a new layer.	In the Layer Editor choose Layers > Create Layer, or click the Create a new layer button on the Layer Editor's toolbar.
Rename a layer.	Double click the layer in the Layer Editor and type the new name in the layer window.
Assign the selected objects to a layer.	Select the layer in the Layer Editor and choose Layers > Add Selected Objects to Current Layer.
Remove the selected objects from whatever layers they are on.	Choose Layers > Remove Selected Object(s) from Layers.
Delete a layer.	Select the layer in the Layer Editor and choose Layers > Delete Selected Layer(s).
Delete layers without any objects.	In the Layer Editor, choose Layers > Delete Unused Layers.

Related topics

- ❖ "Organizing objects" on page 213
- ❖ "Edit all objects on a layer at once" on page 227
- ❖ "Group objects together" on page 227

Edit all objects on a layer at once

To...	Do this
Show the Layer Editor.	Choose Display > UI Elements > Channel Box/Layer Editor, or click the Show or hide the Channel Box/Layer Editor button in the toolbar. Set the pop-up menu to Display.
Show or hide a layer.	Click the left column next to the name of the layer. A "V" in the box means the layer is visible.
Cycle the layer's display type between normal, reference, and template.	Click the middle column next to the name of the layer to cycle through three values: <ul style="list-style-type: none"> • A blank box means the layer is normal. • A "T" means the layer is templated. • An "R" means the layer is reference.
Change the wireframe color of all objects on a layer.	Double click the layer in the Layer Editor and click a color in the layer window.

The Attribute Editor for a layer contains additional, seldom-used attributes in addition to the settings available in the layer window.

To show the Attribute Editor for a layer, select the layer in the Layer Editor and choose Layers > Layer Attributes.

Related topics

- ❖ "Organizing objects" on page 213
- ❖ "Organize objects on display layers" on page 226

Group objects together

When you group objects together, you can select, move, rotate, and scale the group as a single unit.

6 | Files and organization

How do I? > Create and edit sets

To...	Do this
Group the selected objects together.	Choose Edit > Group.
Ungroup the selected group.	Choose Edit > Ungroup.
Select a group.	Open the Outliner (Window > Outliner) and expand the group node to show the objects inside the group, then click the object you want to select.

In terms of the scene hierarchy, the Group command moves the selected objects under a new transformation node.

Related topics

- ❖ "Transformations" on page 103
- ❖ "Scene hierarchy" on page 152
- ❖ "View and edit the hierarchy of nodes" on page 168

Create and edit sets

To create a set with the selected objects

- Choose Create > Sets > Set.

To delete a set

Select the set in the Outliner or Relationship Editor, and press Delete.

Deleting the set does not delete its members.

Related topics

- ❖ "Sets and partitions" on page 213
- ❖ "Keep a collection of sets from having overlapping membership" on page 228

Keep a collection of sets from having overlapping membership

Partitions lets you group sets together while ensuring that the sets do not share members.

How do I? > Keep a collection of sets from having overlapping membership

To create a partition

- 1 Use the Outliner or Relationship Editor to select the sets you want to go in the new partition.
- 2 Choose Create > Sets > Partition.
The sets in the partition are now prevented from having overlapping membership.

To create a new set in a partition

- 1 Select the items you want to go in the new set.
- 2 Choose Create > Sets > Set > .
- 3 Do one of the following:
 - To add the set to a partition only if it's already exclusive (that is, it doesn't overlap with any of the sets in the partition), click Only If Exclusive.
 - To add the set to a partition and remove any members that are already in other sets in the partition, click By Making Exclusive.
- 4 Choose the name of the partition to add this set to from the Partition pop-up menu.
- 5 Click Apply and Close.
If you chose Only If Exclusive and the set overlaps sets in the partition, Maya does not add the set to the partition and a warning appears on the status line.

To edit the membership of a partition

- 1 Choose Window > Relationship Editors > Partitions.
- 2 On the left side, click the partition you want to add to.
- 3 On the right side, click to highlight the sets you want in the partition.
You can also select the sets you want to add to a partition in the Outliner, and then in the Relationship Editor's left side menus choose Edit > Add Selected Items.

To remove a set from a partition

- 1 Choose Window > Relationship Editors > Partitions.
- 2 On the left side, click the plus icon to next to the partition name to show its contents.
- 3 Click the set you want to remove.
- 4 In the Relationship Editor's left side menus choose Edit > Remove Highlighted From Partition.

6 | Files and organization

How do I? > Annotate or document objects

To delete a partition

- 1 Choose Window > Relationship Editors > Partitions.
- 2 Select the partition and press Delete.
Deleting the partition does not delete its member sets.

Related topics

- ❖ "Sets and partitions" on page 213
- ❖ "Create and edit sets" on page 228

Annotate and measure

Annotate or document objects

To attach a label to an object in the scene

- 1 Select the object.
- 2 Choose Create > Annotation.
- 3 Type the label text and click OK.
You can then select and move the label.

To add text notes to a node

- 1 Select the object or node you want to add notes to.
- 2 Type in the Notes field at the bottom of the Attribute Editor.

Related topics

- ❖ "Measure the distance between two points" on page 230
- ❖ "Show parameter or arc-length values on a curve or surface" on page 231

Measure the distance between two points

- 1 Choose Create > Measure Tools > Distance Tool.
- 2 Click two points.
Maya creates two locators with a distance measurement. You can select and move the locators to edit the measurement.
If you snap a measurement locator to an object, the locator moves with the object.

Reference > Show parameter or arc-length values on a curve or surface

Related topics

- ❖ "Show parameter or arc-length values on a curve or surface" on page 231

Show parameter or arc-length values on a curve or surface

To show parameter values

- 1 Choose Create > Measure Tools > Parameter Tool.
- 2 Press the left mouse button on a curve or surface and drag to show parameter values.
Release the mouse button to create a parameter locator.

To show arc-length

- 1 Choose Create > Measure Tools > Arc Length Tool.
- 2 Press the left mouse button on a curve or surface and drag to show arc-length from the beginning of the curve or (0,0) corner of the surface.
Release the mouse button to create an arc-length locator.

Related topics

- ❖ "Measure the distance between two points" on page 230

Reference Menus

File

File > New Scene

Clears the current scene and starts a new one. Maya gives you the chance to save the current scene before clearing it.

File > New Scene >

Enable Default Scene

Turning on this option allows you to choose a file to be loaded into the scene whenever a new scene is created.

6 | Files and organization

Reference > File > Open Scene

Default scene

Click the folder (browse) icon and select a Maya file.

Related topics

- ❖ "Create, open, or save a scene file" on page 219

File > Open Scene

Opens a saved scene from disk.

Note When you open a file with File > Open, the working units (mm, degrees, etc) are changed to those specified in that file. If you want to avoid having the working units changed, use File > Import to read the file.

Related topics

- ❖ "Supported file formats" on page 215
- ❖ "Create, open, or save a scene file" on page 219
- ❖ "Import or reference data in an external file" on page 220
- ❖ "File > Import" on page 237
- ❖ "File > Create Reference" on page 245

File > Open Scene >

General options

File Type

Select the file format you want to use as a default for the next time you open a file.

If you have a project set up, when you open a scene, the browser points to the directory containing files of that type. On Windows and Mac OS X, it also sets the filter to display only files of the selected type.

For example, if you set File Type to DXF, when you open a scene, the Open window displays the contents of *CurrentProject/DXF*. On Windows and Mac OS X, it also sets your filter type to DXF.

Depending on the File Type you select, various File Type Specific Options are displayed.

Execute Script Nodes

Script nodes contain MEL scripts in `mayaAscii` or `mayaBinary` files. You can designate a script node to execute its script when the node is read from a file, or before or after rendering a frame. You can create and edit the script nodes using the Expression Editor. See the chapter “Using Script Nodes” in the MEL book for information on creating and editing script nodes.

User interface configuration information is stored inside the Maya scene file as an attribute on a script node. If you disable the Execute Script Nodes option, the UI script nodes are not executed. However, we recommend disabling script node execution only if you have an error in your script.

Load No References

This opens the file without loading any references. You can load references after the file is open in Maya by opening the Reference Editor (“Reference Editor” on page 253) and selecting the references you want to load.

Load All References

Opens the file with all references loaded. You can change the state of reference loading after the file is open in Maya by opening the Reference Editor (“Reference Editor” on page 253) and selecting the references you want to unload.

Selective Preload

Selecting this option opens the Preload Reference Editor before opening any file (“Preload Reference Editor” on page 255). You can choose to load or defer any references in the file.

mayaAscii, MayaBinary, and MEL. File Type Specific Options

Use Full Names for Attributes on Nodes

Displays the full names of node attributes in the file.

For example, if you select the Use Full Names for Attributes on Nodes option, attribute names are listed as `setAttr.translate 0 0 0` when you open the Maya ASCII file in a text editor. If you turn off the Use Verbose Names option, attribute names are listed as `setAttr .t 0 0 0`.

OBJ File Type Specific Options

Create Multiple Objects

Specifies how shapes are created in OBJ files.

Select True to create individual shapes based on grouping information specified in the OBJ file.

6 | Files and organization

Reference > File > Save Scene

Select False to create one shape for the entire file, with object sets corresponding to each of the specified groups.

You cannot have overlapping groups. If you do, Maya informs you that overlapping groups exist, and re-reads the file as if the option were set to False.

Sound (audio) File Type Specific Options

Sound File Offset

Specifies the time the sound should start playing.

For example, suppose you created an animation of a bird walking a tightrope, and you wanted the sound file to play after the bird reached the end of the rope. If you knew that the bird reached the end of the tightrope at time 108, you would specify a sound file offset of 108.

Move files

You must import move files. See "File > Import" on page 237.

Anim files

You must import anim files. See "File > Import" on page 237.

Illustrator and EPS files

You must import Illustrator and EPS files. See "File > Import" on page 237.

File > Save Scene

Saves the scene under its current name.

Related topics

- ❖ "Supported file formats" on page 215
- ❖ "Create, open, or save a scene file" on page 219
- ❖ "Import or reference data in an external file" on page 220
- ❖ "Export objects to a new file" on page 222
- ❖ "File > Save Scene As" on page 235
- ❖ "File > Export All, Export Selection" on page 242

File > Save Scene >

Incremental Save

When Incremental Save is turned on and you save the scene, a backup folder by the same name is created in the *scenes\incrementalsave* folder and a backup is made of the file that was previously saved to disk. Each time you save, another backup file is created. These backup files are incremental (*filename.001.mb, filename.002.mb*) so the previous backup is not overwritten. The number of incremental backups created is infinite by default.

Limit Incremental Saves

Applies a limit to the number of incremental backup files that Maya creates and stores. The default limit is 20 increments.

Number of Increments

Type a value or drag the slider to specify a limit.

Note When the Limit Increment Saves checkbox is turned on, Incremental Save stores only the limited number of incremental backup files. Once the limit is reached, Maya deletes the oldest incremental file and replaces it with the latest incremental backup file.

File > Save Scene As

Allows you to choose a new name and location for the scene file.

Related topics

- ❖ "Supported file formats" on page 215
- ❖ "Create, open, or save a scene file" on page 219
- ❖ "Import or reference data in an external file" on page 220
- ❖ "Export objects to a new file" on page 222
- ❖ "File > Save Scene" on page 234
- ❖ "File > Export All, Export Selection" on page 242

File > Save Scene As >

File Type

Sets the file type to *mayaBinary* or *mayaAscii*. The default is *mayaBinary*.

6 | Files and organization

Reference > File > Save Scene As

Default File Extensions

Adds the file extension .ma to Maya ASCII filenames and .mb to Maya Binary filenames.

3D Paint Texture Options

These options define how Maya saves file textures created with the 3D Paint Tool when you save a scene.

- | | |
|-------------------|---|
| Always | Saves different versions of the file textures when you save different versions of a scene. Use this setting if you are working on different iterations or versions of the file texture. |
| Unless Referenced | Saves file textures only if the painted character is not referenced. When this option is selected, Maya uses the file textures from the referenced file, even if you save the scene with a new name. If the character is not referenced and you save a copy of the scene with this option selected, Maya creates a copy of the file textures. |
| Never | Does not save a new file texture. Use this setting if you are no longer changing the file textures and want to continue to use the saved file textures, even if you save the scene with a new name. |

Disk Cache Options

This refers to the new jiggle deformer requiring disk cache, which is implemented as a DG node and gets updated during a file save.

- | | |
|--------|--|
| Always | Creates a copy of the jiggle disk cache file when the scene is saved for the first time or saved to a new name. The cache file name corresponds with the scene file name. This is the default. |
| Never | Does not save a copy of the jiggle disk cache file. Use this option to prevent the copy from being created and save disk space. |

In the New Project and Edit Project windows, we've added a Disk Cache option to the list of Data Transfer Locations (File > Project > New, File > Project > Edit Current). This allows you to set the default directory in which to store the jiggle deformer's disk cache files.

Note In both the New Project and Edit Project windows, there is a Disk Cache option in the list of Data Transfer Locations (File > Project > New, File > Project > Edit Current). This allows you to set the default directory in which to store the jiggle deformer's disk cache files.

Unload References

Facilitates selective file loading by saving files with all references unloaded.

Use Full Names for Attributes on Nodes

Displays the full names of node attributes.

File > Optimize Scene Size

Allows you to remove empty, invalid, or unused parts from the scene to reduce its size and complexity.

Choose File > Optimize Scene Size > and turn on or off the types of information to remove, or run individual types of optimizations.

A progress bar displays as Maya optimizes the scene. You can interrupt the operation by pressing Esc. You get a report of all the results of the optimization in the Script editor.

Related topics

- ❖ "Optimize scene size" on page 222

File > Import

Loads data from a scene file into the existing scene.

Related topics

- ❖ "Supported file formats" on page 215
- ❖ "Create, open, or save a scene file" on page 219
- ❖ "Import or reference data in an external file" on page 220

6 | Files and organization

Reference > File > Import

File > Import >

Group

Specifies whether the imported objects are grouped under a single transform when you import the file. Grouping makes it easier to work on the nodes of imported objects. The default is off.

Remove Duplicate Shading Networks

This setting prevents the duplication of geometry and shading networks if you import a file more than once into Maya

Preserve References

If Preserve References is turned on, the references within the imported file are preserved. If it is turned off, all references are imported into or exported within the file; that is, they are no longer references, but are now objects in the scene. The default is off.

Use Namespaces

When you import or reference a scene with the Use Namespaces option turned on, Maya creates a new namespace that contains the imported or referenced data. Turning on the Use Namespaces option ensures that all nodes are uniquely named.

A *namespace* is a grouping of objects under a given name. Each item in a namespace is identified by its own name along with the namespace it belongs to.

By default, the basename of the imported or referenced file is added to the beginning of the imported or referenced object names, separated by colons.

For example, if you are importing a scene named foo.ma that contains an object named ball, after it's imported the ball is named foo:ball.

You can change the prefix by selecting Resolve clashing nodes with this string and entering a prefix.

Tip Before importing or referencing a file, make sure that the renaming prefix contains no invalid characters.

You can create, name, parent, and remove namespaces using the namespace command.

Namespaces do not effect selection, the DAG, the Dependency Graph, or any other aspect of Maya.

Name clash options

When you import a scene into another scene, naming conflicts occur if the nodes share the same name and parent nodes.

To resolve these naming conflicts, you can rename only nodes with the same name and parents (clashing nodes) or you can rename all nodes. You specify whether to use the filename as the prefix (the default) or to create a prefix string.

For more information on node hierarchy, see MEL and Expressions.

Tip We recommend you use namespaces to resolve naming conflicts instead of using the Name clash options when importing or referencing files.

File Type

Choose from the pull-down menu the file type you are importing. If you aren't sure what type of file you are importing, you can select Best Guess.

Depending on the file type you select, various file type specific options may be displayed.

Move file options

The following file type-specific options apply to importing move files:

Attributes

Type the name of an attribute in the Attributes box and click Add to add the attribute to the list of attributes to use when importing or exporting. If the attribute is already included in the list, a duplicate is not made. You can add several attributes at one time by separating them with a space. To remove an attribute, type the name of the attribute and click Remove.

From Channel Box

Click From Channel Box to combine all of the selected objects in Maya, in the order of their selection, with the channels selected in the Channel Box and place them in the list. For example, if sphere and cone are selected, and tx, sx are selected in the Channel Box, sphere.tx sphere.sx cone.tx and cone.sx are added to the list of attribute to import and export.

6 | Files and organization

Reference > File > Import

Remove Selected

Click Remove Selected to remove all of the attributes selected in the list.

Remove All

Click Remove All to remove all of the attributes from the list.

Precision

This is ignored in file export. For file import, this sets the precision of the file.

When you click import or export, the move file is written or read and only the attributes in the list are affected.

Adobe Illustrator® and EPS options

The Illustrator importer cannot import Illustrator text objects. Convert any text objects in your file to paths before you import the file into Maya.

Scale Factor

Allows you to control the scale of the curves produced from the import. It is the same operation as using the Scale Tool.

Group

Turn on this option to group the imported curves. It is the same operation as using the Edit > Group option.

Animation curve options

Time Range

Select a time range option and specify the appropriate settings.

Start	Imports the animation information to the selected objects so that the animation starts at the time specified in the Start Time field.
Start/End	Imports the animation information to the selected object or objects, scaling the animation to fit into the time range as specified in the Start Time and End Time fields. Animation information from the keys clipboard is either scaled or clipped depending on the setting of the Clipboard Adjustment option.
Current	Imports the animation information to the selected objects so that the animation starts at the current time as displayed in the Animation Controls.

Clipboard	Transfers the animation information to the selected object(s), preserving the duration and timing of the animation information on the keys clipboard.
Copies	The value specifies the number of copies of the anim curves that are imported. Multiple copies are appended sequentially.

Help Images

Turn on Help Images to display illustrations of the effects of the various anim import options.

Clipboard Adjustment

Specify an option for how to handle the Clipboard contents.

Preserve	Pastes the contents of the clipboard into their new positions on the curve without any changes.
Scale	Becomes enabled when Start/End is selected. The complete contents of the clipboard curves are stretched or compressed to fit into the specified import Time Range.
Fit	Becomes enabled when Start/End is selected. The contents of the clipboard are preserved (that is, not stretched or compressed) and as much as will fit into the specified time range is pasted into the new area.

Paste Method

Specify a paste method.

Insert	Places the clipboard contents before any existing keys in the specified time range. The keys from the original curve that were after the specified time range are shifted in time by the pasted range times.
Replace	Becomes enabled when Start/End or Clipboard is selected. The clipboard contents overwrite any existing keys in the specified time range.
Merge	The clipboard contents are added to any existing keys on the curve. In the case where a clipboard key is at the same time as an existing key, the clipboard's key replaces the existing key.

Replace Region

These buttons are enabled when Paste Method is set to Replace.

6 | Files and organization

Reference > File > Export All, Export Selection

Time Range	Replace keys and curve segment information in the specified time range with the contents of the keys clipboard.
Entire Curve	Is available only when the Time Range setting is Clipboard. The Entire Curve setting replaces the animation curve(s) on the imported attributes with the contents of the keys clipboard, in effect deleting any existing animation curves on these attributes and applying the new curves from the keys clipboard.

Connect

When turned on, adjusts the keys clipboard curves in value, so there's no discontinuity in the animation at the start of the pasted segment.

File > Export All, Export Selection

Saves all objects or the selected objects to a new scene file.

Related topics

- ❖ "Supported file formats" on page 215
- ❖ "Create, open, or save a scene file" on page 219
- ❖ "Import or reference data in an external file" on page 220
- ❖ "File > Save Scene" on page 234
- ❖ "File > Save Scene As" on page 235

Default File Extensions

Defaults to exporting the file with the extension for that file type.

Preserve References

If Preserve Reference is turned on, the references within the exported file are preserved. If it is turned off, all references are exported within the file; that is, they are no longer references, but are now objects in the scene. The default is off.

Maya native file (.ma and .mb) options

For Maya ASCII (.ma) and Maya Binary formats (.mb), the Export All options are the same as the File > Save Scene As options

- ❖ "File > Save Scene As" on page 235

mental images (.mi) file options

See File > Export All, Export Selection (mental ray) in the *Rendering* guide.

Move file options

Attributes

Type the name of an attribute in the Attributes box and click Add to add the attribute to the list of attributes to use when importing or exporting. If the attribute is already included in the list, a duplicate is not made. To remove an attribute, type the name of the attribute and click Remove. You can add several attributes at one time by separating them with a space.

From Channel Box

Click From Channel Box to combine all of the selected objects in Maya, in the order of their selection, with the channels selected in the Channel Box and place them in the list. For example, if sphere and cone are selected, and tx, sx are selected in the Channel Box, sphere.tx, sphere.sx, cone.tx, and cone.sx are added to the list of attribute to import and export.

Remove Selected

Click Remove Selected to remove all of the attributes selected in the list.

Remove All

Click Remove All to remove all of the attributes from the list.

Precision

This is ignored in file export. For file import, this sets the precision of the file.

When you click import or export, the move file is written or read and only the attributes in the list are affected.

Animation curve options

Precision

Sets the precision of the numbers stored in the file. The choices are:

Float – Eight digits of precision

Double – Seventeen digits of precision

Custom – A setting between 1 and 18.

File Contents

Use Node and Leaf Attribute Names – When the Use Node and Leaf Attribute checkbox is selected, the node and leaf attribute names in the clipboard are written to the file.

6 | Files and organization

Reference > File > Export All, Export Selection

When the checkbox is not selected, only the full attribute name is written to the file.

Verbose Units – When the Verbose Units checkbox is selected, long unit names are used in the file, otherwise short unit names are used.

Hierarchy

The Hierarchy setting provides control over which nodes are copied within a hierarchy.

Selected – Only the selected object's animation copies to the keys clipboard.

Below – Copies the animation of the selected object and all objects below it to the clipboard.

Channels

This setting is available when you want to copy only attributes selected in the Channel Box.

All Keyable – All keyable channels of the selected object's animation are copied to the clipboard.

From Channel Box – Only those channels selected in the Channel Box are copied to the clipboard.

Control Points

This option enables or disables the copy action for all the CVs, polygon vertices, and lattice points associated with a geometry shape (or transform node hierarchically above the geometry shape).

Normally, when a control point is copied, only the selected control point is copied. The Control Points option enables the copying for all the control points associated with an object. This is useful when you are doing control point-intensive animation and don't want to select each control point to copy the animation.

Shapes

This option determines if the animation of a shape attribute of an object as well as the animation of the associated transform attribute are copied, or if only the transform node's animation is copied.

Generally, when an object is selected in a modeling window, the transform node (above the shape hierarchically) is selected.

For example, if a camera, NURBS object, or light is selected, the associated transform node is selected for copying.

Time Range

All – Copies all the animation information of the selected object or objects to the keys clipboard.

Start/End – copies only the animation information in the range specified in the Start Time and End Time fields of the selected object or objects to the keys clipboard.

Help Images

When checked, this option displays a diagram of the copy action, and in particular represents graphically the two methods of copying animation information.

Method

Keys – Copies only keys within the selected range to the keys clipboard.

Segments – Copies animation curve segments and any keys in the selected range to the keys clipboard.

Note The Segments method of copying keys creates keys for the copied animation segment at the start and end times in order to preserve the shape of the animation curve, if keys do not already exist at those points.

File > Create Reference

Lets you import data from an external file by reference. The data remains in the external file and is loaded on the fly when Maya needs it.

Related topics

❖ "Import or reference data in an external file" on page 220

File > Create Reference >

Group

Specifies whether the referenced objects are grouped under a single transform when you reference the file. Grouping makes it easier to work on the nodes of imported objects. The default is off.

6 | Files and organization

Reference > File > Create Reference

Locator

When used with the Group option, groups the contents of the referenced file under a locator, annotated with the reference node name. The reference node has a message connection to the locator's transform.

Use Namespaces

When you reference a scene with the Use Namespaces option turned on, Maya creates a new namespace that contains the imported or referenced data. Turning on the Use Namespaces option ensures that all nodes are uniquely named.

A *namespace* is a grouping of objects under a given name. Each item in a namespace is identified by its own name along with the namespace it belongs to.

By default, the basename of the imported or referenced file is added to the beginning of the imported or referenced object names, separated by colons.

For example, if you are importing a scene named `foo.ma` that contains an object named `ball`, after it's imported the ball is named `foo:ball`.

You can change the prefix by selecting Resolve clashing nodes with this string and entering a prefix.

You can create, name, parent, and remove namespaces using the `namespace` command.

Namespaces do not effect selection, the DAG, the Dependency Graph, or any other aspect of Maya.

Name clash options

When you reference a scene into another scene, naming conflicts occur if the nodes share the same name and parent nodes.

To resolve these naming conflicts, you can rename only nodes with the same name and parents (clashing nodes) or you can rename all nodes. You specify whether to use the filename as the prefix (the default) or to create a prefix string.

For more information on node hierarchy, see MEL and Expressions.

Tip We recommend you use namespaces to resolve naming conflicts instead of using the Name clash options when importing or referencing files.

File type

Choose from the pull-down menu the file type you are importing. If you aren't sure what type of file you are importing, you can select Best Guess.

For more information on file type options, see File > Import.

File > Reference Editor

Opens the Reference Editor. See "Reference Editor" on page 253.

Related topics

- ❖ "Import or reference data in an external file" on page 220

File > Project > New

Starts a new project. A project lets you group together all the different files needed for a scene or group of related scenes.

You can choose the paths of directories for each type of file.

Related topics

- ❖ "Organize files into projects" on page 223

Options

Scenes

Specifies the directory used to save scene files. This directory normally contains only geometry information, unless you instruct Maya to put all of the information on the file into this subdirectory. You can also use this text box to enter search criteria for scene information.

Project Data Locations

Specifies the directories for files containing project textures, lights, source images, images, and render scenes.

Data Transfer Locations

These locations specify the paths to the directories containing files in formats that may require conversion.

6 | Files and organization

Reference > File > Project > Edit Current

Note The location directories can be expanded using plug-ins. Each time you add a plug-in, the New Project window displays the addition. You can then specify the path to the plug-in's directory.

Note If you leave a text box blank, Maya does not create a subdirectory. If you create a scene using an unspecified project setting, Maya saves the information in the project location directory.

File > Project > Edit Current

Lets you edit the paths of the current project. A project lets you group together all the different files needed for a scene or group of related scenes.

Related topics

❖ "Organize files into projects" on page 223

File > Project > Set

Lets you choose a current project to work on. A project lets you group together all the different files needed for a scene or group of related scenes.

Related topics

❖ "Organize files into projects" on page 223

Edit

Edit > Group

Groups objects together under a new transform node, allowing you to select and transform them all at once.

Related topics

❖ "Group objects together" on page 227

Edit > Group > □

Group Under

Group objects under one of the following:

Parent Groups the selected objects under their lowest common parent in the hierarchy. For example, selecting a single object and grouping puts the group node immediately above the selected object in the hierarchy.

Selecting objects that are in different hierarchies puts the group under the world since they don't share a common parent.

Selecting objects in different parts of the same hierarchy puts the objects under their lowest common parent. If you go from each selected object, the new group will be placed under the first node containing all the selected objects.

World Puts the new group under the world (at the top level of the hierarchy).

Group Pivot

Select where you want the pivot point for the group to be.

Center Puts the new group's pivot point at the center of the bounding box of the grouped objects.

Origin Puts the new group's pivot point at the origin of the new group's coordinate system.

Preserve Position

Turn this option on to modify the selected object's matrix so that Maya preserves the overall world-space position of the object. If turned off, the matrix of grouped objects are changed and the object's world-space position changes when grouped.

Edit > Ungroup

Ungroups the objects under a group node.

Related topics

❖ "Group objects together" on page 227

6 | Files and organization

Reference > Edit > Level of Detail

Edit > Ungroup >

Ungroup Under

Ungroup objects under one of the following:

- | | |
|--------|--|
| Parent | Puts all objects under their lowest common parent in the hierarchy. If there is none, then it puts the objects as the world level. |
| World | Puts all objects at world level (at the top-level of the hierarchy). |

Preserve Position

When on, Maya preserves the transformation information of the group. If off, the ungrouped objects lose their grouped transformation attributes, therefore changing their position when ungrouped.

Edit > Level of Detail

Lets you associate multiple versions of some geometry to be replaced based on distance in a game engine. This lets you produce a high-quality version of a model for up-close and a low-quality version for far-away, with multiple versions in between.

- Notes**

 - Level of Detail doesn't handle instances; instanced geometry will not be displayed consistently if it is added into a Level of Detail. Only use uninstanced geometry when creating levels of detail.
 - Edit > Ungroup should not be used with Level of Detail; the LOD threshold information will not be reset properly on Undo. Use Edit > LevelOfDetail > Ungroup to properly ungroup an lodGroup node.

Related topics

- ❖ "Level of Detail group node" on page 271

Adding and editing levels

To add a new level

- 1 Create a new object to add to the level of detail group.
- 2 Do one of the following:
 - In the Hypergraph, use the middle mouse button to drag the new object onto the lodGroup node.

- In the Outliner, use the middle mouse button to drag the new object onto the group.

The new object is added to the bottom of the lodGroup's hierarchy.

Tip You can also re-order a group by selecting Edit > Level of Detail > Ungroup. Re-order the objects and create a new group.

Previewing more than one object at the same time

You can preview different objects at the same time to compare them.

To view more than one object

- 1 In the Hypergraph, select the level of detail group node.
The node's attributes are displayed in the Channel Box. Each Display Level has three possible settings: uselod, show, and hide.
- 2 Use the left mouse button to click on one of the Display Level's uselod text. A drop-down menu with the three options is displayed.
- 3 Select one of the options. You can show or hide any combination of objects.

Tip Reset the Display Levels to uselod to return to the regular level of detail behavior.

Notes about orthographic cameras and level of detail

Level of Detail displays one child of a level of detail group, depending on the group's distance to a camera. For perspective cameras, this means measuring the distance between the camera position to the center of the bounding box of the group.

For orthographic cameras, the distance is measured differently. This is because zooming, panning, and dollying in an orthographic view does *not* change the camera position, but instead changes the camera's *orthographic width*. So the distance is measured as:

$$\text{distance} = (\text{default camera distance}) * (\text{camera's orthographic width}) / (\text{default orthographic width})$$

Substituting Maya's default values in this equation results in the following:

$$\text{distance} = 3.333 * (\text{camera's orthographic width})$$

6 | Files and organization

Reference > Display > Object Display > Template, Untemplate

Display

Display > Object Display > Template, Untemplate

Templated objects appear slightly dimmed. You cannot select or snap to templated objects.

Templating is useful to get objects “out of the way” so you don’t accidentally select them.

Related topics

- ❖ “Make an object unselectable (template)” on page 225

Create

Create > Measure Tools > Distance Tool, Parameter Tool, Arc Length Tool

Create measurement objects that let you measure and annotate objects in the scene. As you move the points of the annotations, the listed measurements automatically update.

Related topics

- ❖ “Measure the distance between two points” on page 230
- ❖ “Show parameter or arc-length values on a curve or surface” on page 231

Create > Locator

Creates a locator object in the scene. A locator is a very simple 3D cross that marks a point in space. They are useful as UI for characters: you can parent joints to the locator so moving the locator pushes and pulls the joint.

Create > Annotation

Creates a text label with an arrow pointing to the selected object.

Deleting annotations does not remove the corresponding locator node from the scene. To delete the locator node, do one of the following:

- After deleting the annotation node, select the locator node and delete it.

- Select the annotation and press the pick walk up hotkey (default is up arrow key). The locator node will be selected and deleting it will also delete the annotation node.
- Selecting File > Optimize Scene Size.

Related topics

- ❖ "Annotate or document objects" on page 230

Create > Sets > Set, Partition

Create sets and partitions. Sets are loose groupings of objects used for various purposes in Maya. Partitions are groupings of sets that ensure the sets do not share members.

Related topics

- ❖ "Create and edit sets" on page 228
- ❖ "Keep a collection of sets from having overlapping membership" on page 228

Create > Empty Group

Creates an empty group node in the scene hierarchy.

Related topics

- ❖ "Transformations" on page 103
- ❖ "Scene hierarchy" on page 152
- ❖ "Group objects together" on page 227

Windows and editors

Reference Editor

The Reference Editor allows you to select the loaded or unloaded state of all references in your scene with the check box icons or commands, and access other reference commands.

File menu

Create Reference

See "File > Create Reference" on page 245.

6 | Files and organization

Reference > Reference Editor

Import Objects from Reference

Imports the selected reference's objects directly into the current scene.

Export Selection as a Reference

Exports the selected objects as a reference and links that reference into the current scene. A file browser opens to save the file with the name and location you specify.

Clean Up Reference

Removes unused file references in the scene file.

Edit Menu

Remove Reference

Removes the selected reference.

Select File Contents

Selects all items in the selected reference file.

Reference Menu

Load Reference/Unload Reference

Loads or unloads the selected reference.

Load Related Reference/Unload Related Reference

Loads or unloads references related to all selected objects.

Replace Reference

Opens a file browser to replace the current reference with the one you select. The group node and/or locator remains the same.

Recent Files

Lists recently-referenced reference files.

File Particulars

The following file information displays when a referenced file is selected in the editor. You can choose to show or hide this information by clicking on the disclosure triangle.

Unresolved Name

Displays a relative or absolute path including name of the referenced file, without locations where Maya searches for the file.

Resolved Name

Displays the filename and path where Maya found the file.

Rename Prefix

Displays a prefix that can be applied to object names in the event of name clashes or namespaces.

Using relative paths and environment variables in the Reference Editor

You can edit reference paths in the Reference Editor, which allows you to specify a reference using relative paths and environment variables.

Enter an environment variable or relative path in the Unresolved Name text box of the Reference Editor, and click Reload to load the reference from that location.

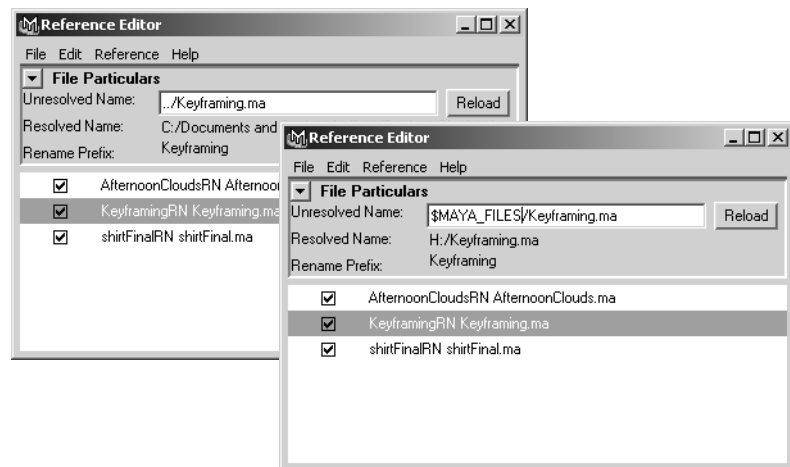

If Maya can't find the referenced file in the specified location, it looks in several default locations to find the file.

Preload Reference Editor

The Preload Reference Editor looks very much like the Reference Editor. It appears when you open a file when the Selective Preload option is turned on in the File > Open > window.

6 | Files and organization

Reference > Layer Editor

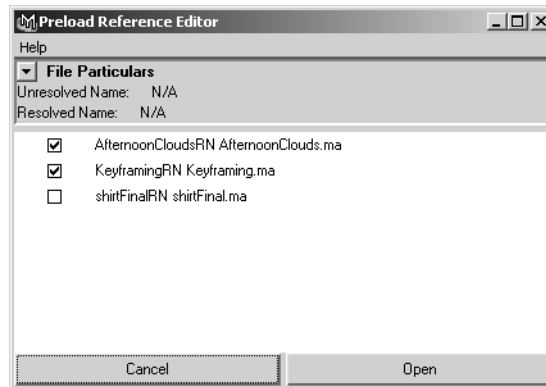

To select which references will be read in (loaded) and which deferred (unloaded)

- 1 Select one or more items in the Preload Reference Editor.
- 2 Do one of the following:
 - Click the checkbox next to each item.
 - Right-click an item and select Bring in Reference Loaded or Bring in Reference Unloaded from the menu that appears.

Note Loading and unloading references works hierarchically; that is, switching the top-level load status of a parent to unloaded means that all children references are also not loaded.

Layer Editor

Lets you organize large-scale pieces of the scene so you can show, hide, or edit them all at once.

Related topics

- ❖ “Organize objects on display layers” on page 226
- ❖ “Edit all objects on a layer at once” on page 227

Layers menu

Create Layer

Creates a new display layer or render layer, depending on the selection in the pull-down menu, with a default name, for example *layer1*.

Layer > Create Layer >

Name	Sets the name of the layer you're creating.
Number	Sets the number of the layer you're creating.
Make the created display layer current	Makes the created display layer current.
Add to new display layer	You can choose to add Nothing, Selected objects or Selected objects and their Children to the layer you're creating.

Delete Selected Layer(s)

Deletes the selected layer(s), but not the objects in the layer.

Edit Selected Layer(s)

Opens the Edit Layer window for the selected layer(s) so you can edit layer attributes.

Select Objects in Selected Layer(s)

Selects the objects contained in the selected layer(s).

Add Selected Objects to Current Layer

Adds the selected objects to the selected layer.

Remove Objects from Selected Layer(s)

Removes all objects from the selected layer(s) and assigns them to the default layer. The selected layer(s) becomes empty so you can assign other objects.

Layer Attributes

Opens the Attribute Editor for the selected layer(s). There are some attributes in the Attribute Editor not available through the Edit Layer window.

Membership

Opens the Relationship Editor for removing or adding objects to layers.

Select Unused Layers

Selects all layers in the Layer Editor that do not have objects assigned to them. This option is only available from the Layer menu and not the right mouse button pop-up menu.

Delete Unused Layers

Delete layers if they have no content.

6 | Files and organization

Reference > Layer Editor

Remove Selected Object(s) from Layers

Removes the selected object(s) from the assigned layer(s). This option is only available from the Layer menu and not the right-mouse button pop-up menu.

Sort Layers Alphabetically

Sorts layers by name.

Sort Layers Chronologically

Sorts layers by time of creation.

Display layer properties window

Display Layer

Type the name of the layer.

Enable Overrides

Turn this option off to disable the effects of the layer. Objects in the layer appear and behave as though they do not belong to the layer.

Display Type

Select how the layer appears.

Normal	Objects in the layer display normally, according to the settings for the layer. You can select objects in the layer and snap to them.
Template	Objects in the layer become templates. You can see template objects in the workspace, but you cannot select them, nor can you snap them.
Reference	You can snap to objects in the layer, but you cannot select them or modify them.

Level of Detail

Select the level of display detail for layer objects:

Full	Displays full detail for layer objects.
Bounding Box	Shows objects as boxes that represent their bounding volumes. Bounding boxes speed up Maya operations making a significant difference for complex models.

Shading

Turn on to make layer objects appear shaded when in shaded display.

Texturing

Turn on to show textures on layer objects when in shaded display.

Playback

Turn on to animate layer objects during playback. If you have several characters in a scene and want to look at each character's animation separately, you can place each character in its own layer and play back the animation of each character as desired.

Visible

Turn on to make the objects in the layer visible.

Color

Select the color of all objects belonging to the layer.

Number

This is the number assigned to the layer.

Merging display layers when importing files

To facilitate the merging of layers when you read in files, select Window > Settings/Preferences > Preferences, click the Files/Projects category, and in the Display Layer section select one of the following options for File Import Merge:

None	All layers read in are put in a new layer, and renumbered and renamed, if necessary to preserve uniqueness.
By Number	All layers read in that have the same index number as an existing layer are merged with that layer rather than creating a new layer.
By Name	All layers read in that have the same name as an existing layer are merged with that layer rather than creating a new layer.

Relationship Editor

Use the Relationship Editor to edit relationships in Maya, where a relationship is a collection or grouping of objects or components. These relationships include:

- sets
- deformer sets
- character sets
- partitions

6 | Files and organization

Reference > Relationship Editor

- display layers
- render layers
- light linking (light-centric and object-centric)
- UV linking (texture-centric, UV-centric, Paint Effects/UV, Hair/UV, and Fur/UV)

Note The Relationship Editor is separate from the Dynamic Relationships Editor, which is used to control relationships of particle objects.

Related topics

- ❖ "Organize objects on display layers" on page 226
- ❖ "Create and edit sets" on page 228
- ❖ "Keep a collection of sets from having overlapping membership" on page 228

Menus

List

Auto Load All Sets

Turn this on to automatically display *all* relationships of the selected type in the scene. This is the default.

Manual Load Sets

Turn this on to display relationships by choosing one of the following options:

Load Set from Selection

Display only the relationships associated with the objects selected in the scene.

Add Set from Selection

Add to the display the relationships associated with the objects selected in the scene.

Remove Set from Selection

Remove from the display the relationships associated with the objects selected in the scene.

To display objects

On the right side panel, select one of the following options from the List menu.

Auto Load All

Turn this on to automatically display *all* objects in the scene.

Auto Load Selection

Turn this on to automatically display objects in the relationships associated with the objects selected in the scene.

Manual Load

Turn this on to display objects by choosing one of the following options:

Load List from Selection	Display only the selected objects.
Add Selection to List	Add to the display the objects selected in the scene.
Remove Selection from List	Remove from the display the objects selected in the scene.

Toolbar

Drop down menu

Controls which type of relationship to edit. This is the same as the items in the Window > Relationship Editors submenu.

Plus and Minus icons

When you are editing a container-like relationship, such as sets, partitions, or characters, the plus and minus icons add or remove the current selection from the highlighted container in the editor.

For example, if you are editing sets, you can highlight a set on the left side of the editor and click the Plus icon to add the currently selected objects to the set.

Panels

- Type text in the text boxes at the top of each panel to only show items with that text in their names. Click the icon to the left of the text boxes to switch the filter on or off.
- Click a set on the left side, then click items on the right side to highlight or unhighlight them. Highlighted items on the right are connected to the item on the left.

6 | Files and organization

Reference > Color editor

Color editor

The color editor appears whenever you click a color swatch. You can also open it by choosing Window > Settings/Preferences > Colors.

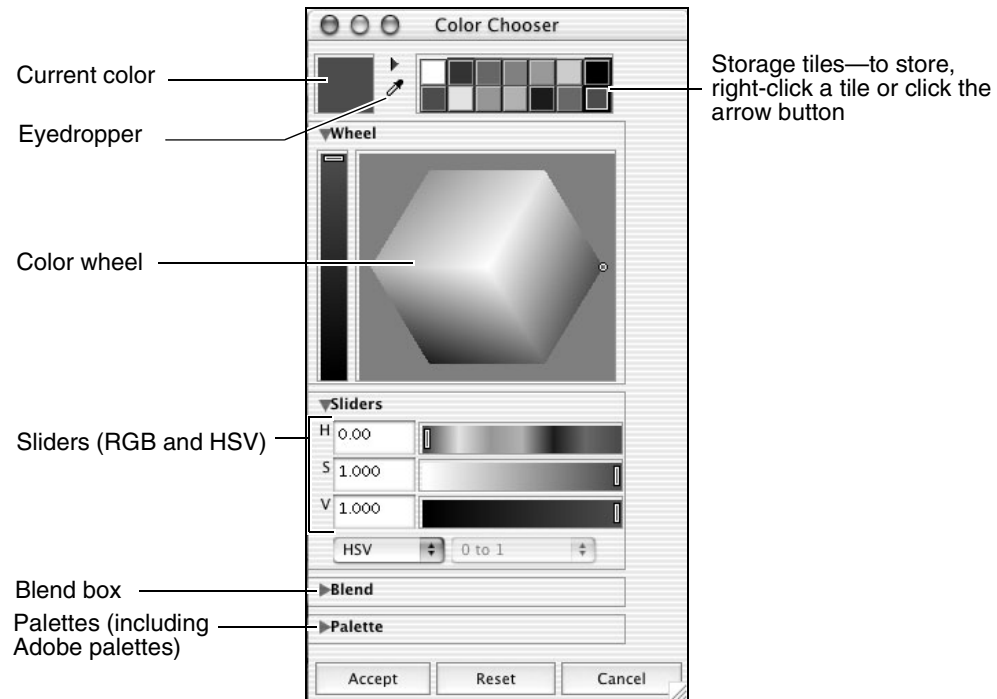

Related topics

- ❖ "Change an object's wireframe color" on page 68
- ❖ "Change user interface colors" on page 273

Controls

Color wheel and storage tiles

The fastest way to select a color is to drag the selector in the color wheel. Once you have the color selected, you can drag the brightness control on the left.

Another quick way to select a color is to left click on one of the storage tiles at the top. To store the current color on a tile, right click a tile or click the arrow button.

Eyedropper

The eyedropper tool lets you grab a color from anywhere on the computer screen, including other applications. Click the eyedropper button, then position the eyedropper cursor anywhere on your screen. Click again to grab the color.

Using the sliders

For precise color selection, you can use the color sliders. You can switch between RGB sliders (Red, Green, Blue) or HSV (Hue, Saturation, Value), depending on the color model you want.

HSV

In this color model, Hue corresponds to the pure colors of the rainbow, such as yellow, blue, and green. Saturation is the amount of white mixed with the hue to set the intensity of the color. Value is the amount of black mixed with the hue to make it darker. If the Value is 0 (zero), then the color is black, regardless of the values for Hue and Saturation.

RGB

This color model describes how red, green, and blue light combines at different intensities to produce different colors. Using RGB, you can choose which value range you want.

0 to 1	Each component color has a value from 0 to 1.
0 to 255	Each component color has a value from 0 (zero intensity) to 255 (full intensity). This model is useful because it relates directly to how monitors emit light to create colors. However, it is often hard for people to figure out what the RGB values are for a specific color.

A (alpha) slider

With the A (alpha) slider, you can control the opacity or transparency of the color you choose. Many Maya options already have an alpha or transparency control, but if it does not or you are calling the Color Chooser from the command line, you can use this slider to control the alpha channel.

❖ "Organize objects on display layers" on page 226

Blend box

The Blend box creates a blend between colors so that you can select a new color from the blended gradient. The following illustration explains how to use it.

6 | Files and organization

Reference > Color editor



Palette

In the Palette section, you can create and save custom color palettes. You can also open Adobe color palettes (file extension .aco), if it is in one of the following formats: RGB, HSV, CMYK, Lab, or Inverted Lab. (Other formats, such as Pantone, are not supported.)

The following illustration highlights the palette components.

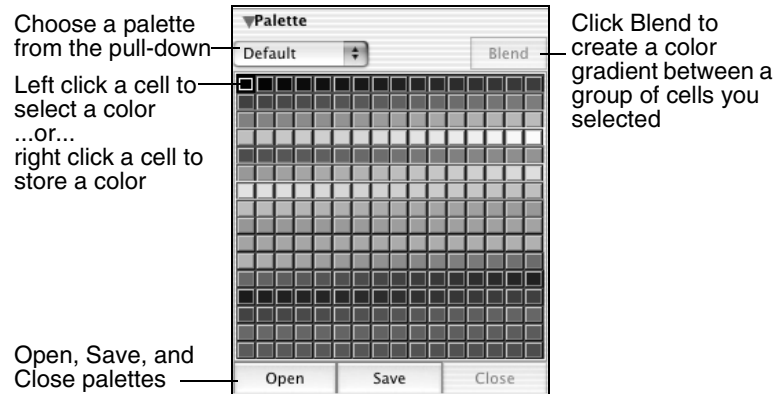

To create a custom palette

- 1 Select a color using any of the Color Chooser tools, such as the Wheel.
- 2 Right click on any tile to store the current color there.
- 3 To create a blended gradient, select several tiles by dragging the mouse, then click Blend.

A color gradient is created between the first and last tiles in your selection. For example, as shown below, you may want more color gradations than in the default palette.



- 4 When finished assigning colors, click Save and specify the filename. You can save the file in any directory. It is saved in ascii format.

Visor

Window > General Editors > Visor

The Visor displays textures, images, and shading nodes in the project directory.

Visor tabs contain a collection of items in the scene, or directories and files on disk. You can customize the way you view files, and create and customize tabs.

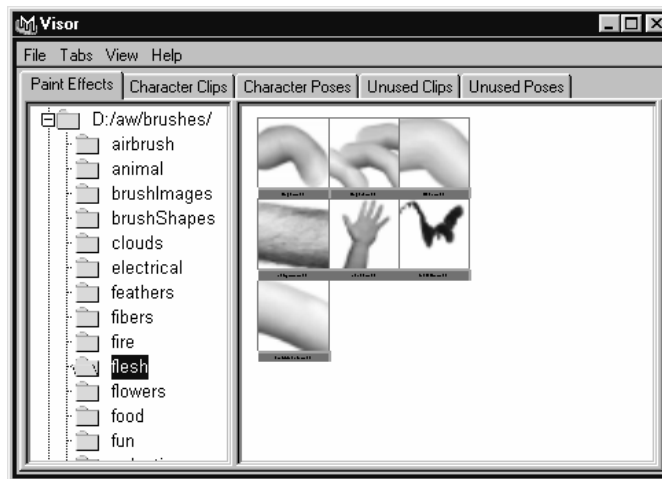

You can also drag items with the middle mouse button from Visor into Hypershade to create a new node, or onto a swatch in Hypershade to connect nodes.

To view an image

Double-click an image file in the images directory to view the image in fcheck.

To create a new tab

- 1 Select Tabs > Create New Tab.
- 2 Enter a new tab name.
- 3 Select a Tab Type and specify the corresponding options.
- 4 Click Create.

Scene

Displays a collection of nodes in the current scene.

6 | Files and organization

Reference > Visor

Disk

Displays files on disk, such as a texture library.

Paint Effects

Displays Paint Effects files, such as brush settings.

Show Nodes Which Are

For Scene tabs, select to display only certain nodes types within a specified tab.

Root Directory

For Disk and Paint Effects tabs, either type the path name if you know it, or click the folder icon to browse through directories to select the directory where the items are stored.

Only Show Files (Hide Directory Tree)

For Disk and Paint Effects tabs, turn this on or off to hide or show the directory tree. This is especially helpful if you find you routinely work with files located in one specific directory. You can switch between viewing directory folders or just the files within that directory.

Menus

File menu

Import

Opens the Import dialog box so you can select a Maya scene file (such as a file containing a shader) to import into Maya.

Import Selected Scene Files

Reads information from another file and loads it into the current file.

Import Selected Image Files

Select an item from the pull-out menu to choose how to import image files. Include Placement is on by default.

As Normal For normal textures, Maya applies a texture map according to the geometry characteristics—textures are placed onto polygons based on UV information or placed onto NURBS surfaces based on parametrized information.

As Projection To create projection textures, Maya applies a texture map to the surface of a 3D object by projecting a 2D texture into 3D space—in other words, Maya projects the texture maps independently of the geometry characteristics.

Tip For textures created with As Projection turned on, you need to explicitly connect the texture to the bump so the texture is visible in the bump map.

As Stencil Lets you place an image file or texture on a surface and manipulate its placement and size to look like a label. You can use masking techniques to hide unwanted parts of the image.

Include Placement When on, Maya automatically creates a texture placement node when you create a texture render node. The default setting is on.

Export Selected Network

Exports the selected item into a new file. The file browser opens to its best guess directory, but can browse to any directory, or cancel, before exporting.

View menu

Frame Selected

Frames only the selected nodes in the current Visor layout.

Frame All

Frames all the nodes displayed in the current Visor layout.

Tabs menu

Each tab contains the nodes that make up the current scene. These options let you create new tabs and customize the default tabs.

Create New Tab

You can create and name tabs to help you organize a scene's rendering elements.

Move Tab Left/Right

Select a tab then select one of these options to re-arrange the tabs.

Rename Tab

Select a tab then select this option to rename it.

Remove Tab

Select a tab then select this option to remove it.

6 | Files and organization

Reference > General attributes

Revert to Default Tabs

Removes new tabs and reverts to the default organization.

Current Tab Options

Select a tab, then select one of these options to control the display: Show Directories Only, Show Files Only, Show Both, Refresh File Listing.

Nodes

General attributes

General attributes

- the name of the node (for example, nurbsSphere1 or lambert1)
- Input Connection button 

Click the Input Connection button to display the first input connection node for the currently displayed node. Right-click the Input Connection button to display a list of all input connection nodes. You can then choose a node from this list to display in the Attribute Editor.
- Output Connection button 

Click the Output Connection button to display the first output connection node for the currently displayed node. Right-click the Output Connection button to display a list of all output connection nodes. You can then choose a node from this list to display in the Attribute Editor.
- Focus button — Click this button to set the Attribute Editor focus to this node.
- a sample image or icon that represents the node (where appropriate)
- Select button — Click this button to select the node that is currently displayed in the Attribute Editor.
- Load Attributes button — Click this button to manually load the attributes of the selected object or node.
- Copy Tab button — Click this button to create a new window containing the selected tab.

Transform attributes

Translate

Specifies the object's translation (Translate X, Y, and Z) attribute values in world space.

Rotate

Specifies the rotation (Rotate X, Y, and Z attribute values) of the object in world space.

Scale

Specifies the objects's scale (Scale X, Y, and Z) attribute values in world space.

Rotate Order

Specifies the object's rotation order. You can set the rotate order when you want a specific final rotation for an object, because each rotate order option produces a different end orientation. For example, if the rotation order for an object is set to xyz, the object first rotates about its X-axis, then its Y-axis, and finally its Z-axis. Default is xyz.

Rotate Axis

Offsets the orientation of the object relative to the orientation of the object's local rotation axis.

Inherits Transform

When this attribute is on, the current object inherits the transformations (Translate, Rotate, Scale, and Shear values) of its parent object.

Display

Sets the overall display settings for the current object.

Display Handle

When this attribute is on, the display handle for the current object is displayed.

Display Local Axis

When this attribute is on, the local axis of the current object is displayed.

Selection Handle (xyz)

Lets you offset the selection handle in the X, Y, and Z axes from the object relative to the handle's current position.

Show Manip Default

Sets the current object's default manipulator shape.

For more information, search the online help for the Manipulator Tool.

6 | Files and organization

Reference > Node behavior

Manip History Node

Sets the specified shape as the default manipular, instead of using one of the defaults.

Visibility

When this attribute is on, the current object is visible in the scene view. When this attribute is off, the current object is hidden in the scene view.

Template

When this attribute is on, the current object is appears a template. See *"Display > Object Display > Template, Untemplate"* on page 252 and *"Make an object unselectable (template)"* on page 225.

LOD Visibility

If the current object is connected to a *lodGroup* node, then this check box displays the Hide/Show status of the object's display level. Also, this attribute is read-only.

If the current object is not connected to a *lodGroup* node, this attribute turns off the objects visibility in the scene view.

Node behavior

To change node behavior, select the node and expand the Node Behavior section of the Attribute Editor.



Caching

Turn Caching on to temporarily store input node evaluations in the cache. When Maya needs these evaluations (as input to the node), it uses the information stored in the cache rather than re-evaluating the input node. If no changes have been made to the node, it redraws more quickly. The cache is destroyed when you edit an attribute. Note that caching uses more memory, which could affect Maya's performance.

Node State

Changing the node state can improve performance. There are six possible node states:

Normal	Causes the node to behave normally, according to the defined settings and effects. This is the default.
--------	---

HasNoEffect	<p>Disables any effects on the node so that fewer calculations are necessary at the time of redraw. The effect does not render until you reset the Node State back to Normal. Maya evaluates the nodes in the node's history, but not the node itself.</p> <p>For example, if you translate a cluster to deform a geometry, then set the Node State of the cluster node to HasNoEffect, the geometry appears undeformed, as though the translation had not occurred. To view the effect, change the Node State back to Normal.</p>
Blocking	<p>Temporarily hides the node and does not display the results of any input (input evaluations) to the node. This can speed the redraw. It is also useful when you have complex scenes and want to edit only one aspect of a node. Blocked nodes do not render.</p> <p>For example, if you have a complex revolved surface and want to edit the curve, but don't want to wait while the curve redraws, select Blocking and edit the curve. To display the modified revolved surface, reset the Node State to Normal.</p>

Notes

- The "HasNoEffect" state has a different meaning for each node type. Some node types do not implement the state, in which case the state acts just like "Normal".
- The "Waiting" node states are used internally by Maya to keep track of nodes that are waiting for a view update in the Hypergraph. You should not normally set nodes to a "Waiting" state.

Level of Detail group node

In the Level of Detail (LOD) group's Attribute Editor, you can modify the following LOD Attributes:

Min Max Distance	If the minMaxDistance is turned off (default) there is no change in behavior. If it is turned on, the minDistance and maxDistance attributes define the visibility range for the object.
Min Distance	The minimum distance at which the group is displayed.

6 | Files and organization

Reference > Level of Detail group node

Max Distance The maximum distance at which the group is displayed.

Changing the Threshold distances

You can change the distances at which the levels are switched using the Channel Box.

To change a Threshold distance

- 1 Select the level of detail group node in the Hypergraph. Its level of detail attributes are displayed in the Channel Box.
- 2 Edit the Threshold value for the object whose distance you want to change, and press Enter (Linux, IRIX and Windows) or Return (Mac OS X).

Re-ordering the levels

You can re-order the levels after you create a level of detail group.

To re-order the levels in the Outliner

In the Outliner, use the middle mouse button to drag the object you want to move into its new position within the group. This is the easiest way to re-order the levels.

To re-order the levels in the Hypergraph

- 1 In the Hypergraph, use the middle mouse button to remove the object you want to re-order from the group. The other objects in the group move up the group hierarchy.
- 2 Use the middle mouse button to drag the removed object onto the lodGroup node. The object is added to the bottom of the lodGroup's hierarchy.

Tip You can also re-order a group by selecting Edit > Level of Detail > Ungroup. Re-order the objects and create a new group.

7 Preferences and customization

How do I? Customize Maya

Customize the look and feel of the interface

Show or hide user interface elements

To...	Do this
Show or hide a specific part of the user interface	Open the Display > UI Elements submenu and choose an item.
Hide all user interface and only show the view/ editor panels.	Choose Display > UI Elements > Hide UI elements.

Related topics

- ❖ "Main window" on page 18
- ❖ "Display > UI Elements" on page 41

Change user interface colors

To open the color editor

- 1 Choose Window > Settings/Preferences > Colors.
- 2 The three tabs control different color uses and work slightly differently:
 - The General tab lets you change user interface and view panel colors, including the view background color.
 - The Active and Inactive tabs let you change the colors of selected and unselected objects and components.

To change a color on the General tab

- Click the arrow next to a section heading to show the colors inside.
- Double-click a color swatch to edit it or drag the slider next to a color to change its brightness.

7 | Preferences and customization

How do I? > Create a custom panel layout

To change a color on the Active or Inactive tabs

In the Active and Inactive tabs, you cannot edit the colors directly. Instead, you set up a palette of available colors (at the top of the tab) and then choose each active or inactive color from that palette.

- Double-click a color swatch at the top of the tab to edit the palette of available colors.
- Click the arrow next to a section heading to show the colors inside.
- Drag the slider next to a color to change which color Maya uses from the palette.

Related topics

- ❖ "Change an object's wireframe color" on page 68
- ❖ "Window > Settings/Preferences > Colors" on page 298

Create a custom panel layout

To create a new custom panel layout

- 1 Set up the layout, panel sizes, and panel contents you want.
- 2 In a panel, choose Panels > Panel editor.
- 3 Click the Layouts tab.
- 4 Click New Layout.
- 5 Type a descriptive name for the layout in the Name text box.

To assign a custom layout to one of the icons in the Quick Layout bar below the toolbox

- 1 Create custom panel layout.
- 2 In the Quick Layout bar, press the right mouse button on the thumbnail you want to assign the new layout to, and choose the layout from the menu.
- 3 To change the thumbnail image, press the right mouse button on the thumbnail again and choose Change Image. You can choose a pre-made image or load an icon image from a file.

To delete a saved layout

- 1 In a panel, choose Panels > Panel editor.
- 2 Click the Layouts tab.
- 3 Click the layout name, then click Delete.

7 | Preferences and customization

How do I? > Add a new panel to the list of available panels

Related topics

- ❖ "Change the panel layout" on page 60
- ❖ "Add a new panel to the list of available panels" on page 275
- ❖ "Quick layout buttons" on page 69
- ❖ "Panel editor" on page 93

Add a new panel to the list of available panels

You can add a new item to the list of available panel contents. This lets you have more than one instance of a particular type of panel.

For example, you might create a character with so many parts that you can't view the entire skeleton in the Outliner. In this case, you could create a second Outliner panel so you could view different parts of the hierarchy at the same time.

Not all panels can be duplicated. For example, only one Hypergraph panel is allowed.

To create a new panel

- 1 In a panel choose Panels > Panel Editor and click the New Panel tab.
- 2 Click the name of a panel (such as the Outliner), then click Make New Panel.
- 3 In a panel, choose the new item from the Panels > Panel menu.

To delete a panel you created

Once you have deleted a panel, you cannot restore it.

- 1 In a panel choose Panels > Panel Editor and click the Panels tab.
- 2 Click the panel you want to delete, then click Delete.

Change the length (scale) of normals in the display

Occasionally you may want to change the length of normals (lines indicating the normal direction of a face or vertex) to make them more visible or less distracting. You can change the scale of normals on a per-object basis.

7 | Preferences and customization

How do I? > Create, rename, rearrange, or delete a shelf

To...	Do this
Change the size of normals on polygonal surfaces.	<ul style="list-style-type: none">• Show the Attribute Editor for the surface.• Open the Mesh Component Display section.• Turn on Display Normal and set the Normal Size.
Change the size of normals on subdivision surfaces.	<ul style="list-style-type: none">• Show the Attribute Editor for the surface.• Open the Subdiv Surface Display section.• Set the Normals Scale.

Customize shelves

Create, rename, rearrange, or delete a shelf

To open the shelf editor

- 1 Choose Window > Settings/Preferences > Shelves.
- 2 Click the Shelves tab.

To add a new shelf

- 1 Open the shelf editor.
- 2 Click New Shelf.
- 3 Type a name for the shelf in the text box.

To rename, rearrange, or delete a shelf

- 1 Open the shelf editor.
- 2 In the list box, click the shelf you want to edit.
- 3 Do any of the following:
 - To rename the shelf, type a new name in the text box.
 - To change the shelf's position on the shelf bar, click Move Up or Move Down.
 - To delete the shelf, click Delete Shelf.

7 | Preferences and customization

How do I? > Add a tool, action, or MEL script to a shelf

Related topics

- ❖ "Add a tool, action, or MEL script to a shelf" on page 277
- ❖ "Edit the contents of a shelf" on page 278
- ❖ "Change the display of shelves" on page 279
- ❖ "Window > Settings/Preferences > Shelves" on page 300

Add a tool, action, or MEL script to a shelf

To add a tool to a shelf

- 1 Choose the tool.
- 2 Drag the tool icon with the middle mouse button from the tool box onto the shelf.

You can add multiple versions of the same tool with different settings to a shelf. For example, you can add a Sculpt Surfaces Tool with the Push option selected and another Sculpt Surfaces Tool with the Pull operation selected. This only works with tools, not regular menu items (actions).

To add a menu item (action) to a shelf

- 1 Click the shelf you want to add the menu item to.
- 2 Open the menu with the menu item you want to add.
- 3 Do one of the following:
 - (Windows and Mac OS X) Hold Ctrl + Shift and click the menu item.
 - (IRIX) Hold Ctrl + Shift + Alt and click the menu item.
 - (Linux) Hold Shift + Alt and click the menu item.

To add a MEL command or script to a shelf

- 1 In the Script Editor (Window > General Editors > Script Editor), select the MEL commands you want to add to the shelf.
- 2 Drag the selection with the middle mouse button from the editor onto the shelf.

To add a panel layout to a shelf

- 1 Click the shelf you want to add the layout to.
- 2 In a panel, choose Panels > Panel editor.
- 3 Click the Layouts tab.
- 4 Click the layout name, then click Add to Shelf.

7 | Preferences and customization

How do I? > Edit the MEL script associated with a shelf item

Related topics

- ❖ "Create, rename, rearrange, or delete a shelf" on page 276
- ❖ "Edit the MEL script associated with a shelf item" on page 278

Edit the MEL script associated with a shelf item

- 1 Click the shelf tab containing the item.
- 2 Choose Window > Settings/Preferences > Shelves.
- 3 On the Shelf Contents tab, click the name of the item.
- 4 Click the Edit Commands tab.
- 5 Edit the commands in the text box and press Enter.

Related topics

- ❖ "Add a tool, action, or MEL script to a shelf" on page 277
- ❖ "Window > Settings/Preferences > Shelves" on page 300

Edit the contents of a shelf

To...	Do this
Remove an icon from a shelf.	Drag the icon with the middle mouse button onto the trash icon in the upper right corner of the shelf bar.
Rearrange icons on a shelf.	Drag the icon with the middle mouse button to a different position on the shelf.
Move an icon to another shelf.	Drag the icon with the middle mouse button onto the shelf tab you want to move the icon to.
Copy an icon to another shelf.	Hold Ctrl and drag the icon with the middle mouse button onto the shelf tab you want to copy the icon to.

Related topics

- ❖ "Create, rename, rearrange, or delete a shelf" on page 276
- ❖ "Add a tool, action, or MEL script to a shelf" on page 277
- ❖ "Use a custom name or icon for a shelf item" on page 279

7 | Preferences and customization

How do I? > Use a custom name or icon for a shelf item

- ❖ "Change the display of shelves" on page 279
- ❖ "Window > Settings/Preferences > Shelves" on page 300

Use a custom name or icon for a shelf item

To select an item in the shelf editor

- 1 Click the shelf tab containing the item.
- 2 Choose Window > Settings/Preferences > Shelves.
- 3 On the Shelf Contents tab, click the name of the item.

To use a custom icon for a shelf item

- 1 Select the item in the shelf editor.
- 2 Click Change Image.
- 3 Use the file open dialog box to choose a 32 by 32 pixel image.
The image must be in XPM, BMP (Windows only), or IFF format.

To change the name of a shelf item as it appears in lists and tooltips

- 1 Select the item in the shelf editor.
- 2 Type the new name in the Label & Tooltips text box and press Enter.

To overlay a short text label on an icon

- 1 Select the item in the shelf editor.
- 2 Type up to four characters in the Icon Name text box and press Enter.
The characters are overlaid on the icon.

Related topics

- ❖ "Change the display of shelves" on page 279

Change the display of shelves

To...	Do this
Hide the shelf tabs to save space.	Press the left mouse button on the black triangle to the left of the shelf area. In the pop-up menu, turn off Shelf Tabs.

7 | Preferences and customization

How do I? > Create or edit a marking menu

To...	Do this
Switch shelves when the shelf tabs are hidden.	Press the left mouse button on the small tab icon to the left of the shelf area. In the pop-up menu, choose the shelf to display.

Related topics

❖ “Use a custom name or icon for a shelf item” on page 279

Customize marking menus and the hotbox

Create or edit a marking menu

Making a new marking menu is a two step process: first you create the marking menu. Then to actually use the marking menu you assign it to a hotkey or to a region of the hotbox.

You can add multiple versions of the same tool with different settings to a marking menu. For example, you can add a Sculpt Surfaces Tool with the Push option selected and another Sculpt Surfaces Tool with the Pull operation selected. This only works with tools, not regular menu items (actions).

To...	Do this
Open the Marking Menus dialog box.	Choose Window > Settings/Preferences > Marking Menus.
Start a new marking menu.	In the Marking Menus dialog box, click Create Marking Menu.
Edit an existing marking menu.	In the Marking Menus dialog box, click the name of the marking menu you want to edit, then click Edit Marking Menu.
Add an item to a marking menu.	<ol style="list-style-type: none">1 Start a new marking menu or edit an existing one.2 Use the middle mouse button to drag items onto spaces in the marking menu editor. You can do any of the following:<ul style="list-style-type: none">• Drag a tool from the tool box.• Drag a shelf item from the shelf.• Drag selected text from the Script Editor.

7 | Preferences and customization

How do I? > Assign a marking menu to a hotkey

To...	Do this
Change the label or MEL script of an item.	Press the right mouse button on an item and choose Edit Menu Item.
Make an item open a submenu.	Press the right mouse button on a space in the marking menu editor and choose Popup Submenu. When you're finished editing the submenu, close the submenu's window.
Delete an item.	Press the right mouse button on an item and choose Delete Menu Item.
Save your changes to a marking menu.	Click Save and close the marking menu editor window.
Set when the marking menu appears.	<ul style="list-style-type: none">• "Assign a marking menu to a hotkey" on page 281• "Add a marking menu to the hotbox" on page 282

Related topics

- ❖ "Assign a marking menu to a hotkey" on page 281
- ❖ "Add a marking menu to the hotbox" on page 282

Assign a marking menu to a hotkey

Marking menus appear when you hold a hotkey and press the left mouse button. You can set a hotkey to show one of the pre-made marking menus that come with Maya, or a custom marking menu you have created.

To assign a marking menu to a hotkey

- 1 Choose Window > Settings/Preferences > Marking Menus.
- 2 Click the marking menu in the list.
- 3 Set the Use Marking Menu In option to Hotkey Editor.
- 4 Click Apply Settings.
- 5 Choose Window > Settings/Preferences > Hotkeys.
- 6 In the Categories list on the left, click User Marking Menus.

7 | Preferences and customization

How do I? > Add a marking menu to the hotbox

- 7** For each marking menu you've created, the list has two items in the Commands list: *"menu_Press"* and *"menu_Release"*. Click the "press" command.
- 8** Type a key name in the Key text box and turn on any modifiers you want on the hotkey.
For example, type *m* in the text box and turn on the Alt setting to assign the marking menu to alt + m.
As you edit these settings, Maya shows the command currently assigned to the hotkey, if any. Only assign the hotkey if you don't mind overriding this command.
- 9** Set the Direction option to Press.
- 10** Click Assign.
If the hotkey you set already has a command assigned, Maya asks if you want to override it.
- 11** Maya warns you that it should assign the release command also. Click OK to do this.

Related topics

- ❖ "Create or edit a marking menu" on page 280
- ❖ "Add a marking menu to the hotbox" on page 282

Add a marking menu to the hotbox

Marking menus appear in the hotbox when you point above (north), below (south), left (west), or right (east) of the hotbox menus and press a mouse button.

You can set each mouse button press (left, middle, or right) in each different area (north, south, east, or west) to show one of the pre-made marking menus that come with Maya, or a custom marking menu you have created.

To assign a marking menu to a hotbox area and mouse button

- 1** Choose Window > Settings/Preferences > Marking Menus.
- 2** Click the marking menu in the list.
- 3** Set the Use Marking Menu In option to Hotbox.
- 4** Set the Hotbox Region option to the part of the hotbox (North, West, Center, East, or South) where the marking menu appears.
- 5** Set the Mouse Button(s) option to the mouse buttons (Left, Middle, and/or Right) you must hold for the marking menu to appear.

7 | Preferences and customization

How do I? > Customize the hotbox

For example, if you set the region to South and turn on Middle and Right, the marking menu appears when you show the hotbox (hold the space bar), move the mouse pointer below the menus, and press the middle and right mouse buttons.

- 6 Click Apply Settings.

Related topics

- ❖ "Create or edit a marking menu" on page 280

Customize the hotbox

To change what functions are available in the hotbox

- 1 Hold the space bar to show the hotbox.
- 2 Press the left mouse button in the Hotbox Controls area to show the marking menu.
- 3 Drag down to the Hotbox Style sub-menu.
- 4 Choose one of the following options:
 - Zones and menu rows: show all menus, as well as the "zones" containing marking menus above, below, left, and right of the hotbox.
 - Zones only: don't show all menus.
 - Center zone only: only show the center marking menu. This makes the hotbox equivalent to a hotkey marking menu.

To change what extra menus are available in the hotbox

- 1 Hold the space bar to show the hotbox.
- 2 Press the left mouse button in the Hotbox Controls area to show the marking menu.
- 3 Drag left, right, up, or down to show sub-menus allowing you to either not show a menu set or only show that menu set.

To change the way you access the extra menus

You can set up Maya to hide the extra menu sets at the bottom of the hotbox, and show them as pop-up menus by pressing the right mouse button in the center of the hotbox.

- 1 Hold the space bar to show the hotbox.
- 2 Press the left mouse button in the Hotbox Controls area to show the marking menu.
- 3 Drag down to the Hotbox style submenu.

7 | Preferences and customization

How do I? > Assign a predefined command to a hotkey

- 4 In the submenu, turn on the Center zone RMB pop-ups option.

Related topics

- ❖ "Add a marking menu to the hotbox" on page 282
- ❖ "Hotbox Controls > Hotbox Style" on page 302

Customize hotkeys

Assign a predefined command to a hotkey

Maya includes a number of pre-made commands that correspond to the actions you can accomplish with the user interface (for example, opening editors or creating objects). These commands are organized into categories.

To assign a command to a hotkey

- 1 Choose Window > Settings/Preferences > Hotkeys.
- 2 Click a category name in the Categories list to show a sublist of commands, then click the command you want to assign a hotkey to.
To find a command in the categories, click Search (near the bottom of the hotkey editor window) and type some text to find. Use * to match anything. To find all commands that start with Delete, type `delete*`. To find all commands with the word "light", type `*light*`.
- 3 Type a key name in the Key text box and turn on any modifiers you want on the hotkey.
For example, type `m` in the text box and turn on the Alt setting to assign the marking menu to `alt + m`.
As you edit these settings, Maya shows the command currently assigned to the hotkey, if any. Only assign the hotkey if you don't mind overriding this command.
- 4 Set the Direction option. If you choose Press, Maya runs the command when you press the key down. If you choose Release, Maya runs the command when you let the key up.
The distinction between Press and Release can be important, for example when you assign a hotkey to a snapping mode. You want to assign the command that turns the snapping mode *on* to the key *press*, and the command that turns the snapping mode *off* to the key *release*.
- 5 Click Assign.
If the hotkey you set already has a command assigned, Maya asks if you want to override it.

7 | Preferences and customization

How do I? > Assign a MEL script to a hotkey

Related topics

- ❖ "Assign a marking menu to a hotkey" on page 281
- ❖ "Assign a MEL script to a hotkey" on page 285
- ❖ "View a list of all assigned hotkeys" on page 286
- ❖ "Hotkey editor" on page 329

Assign a MEL script to a hotkey

To associate a MEL script with a hotkey, you must first add the script to the list of available hotkey commands, then assign a hotkey to the command you created.

- 1 Choose Window > Settings/Preferences > Hotkeys.
- 2 Commands are grouped into categories. Click the category name in the Categories list you want to put your script in.
- 3 In the command area at the bottom of the hotkey editor, click New.
- 4 Type a Name and Description for the new command.
- 5 In the Command text box, type the MEL commands you want the hotkey to run.
- 6 Click Accept.
- 7 Type a key name in the Key text box and turn on any modifiers you want on the hotkey.

For example, type `m` in the text box and turn on the Alt setting to assign the marking menu to `alt + m`.

As you edit these settings, Maya shows the command currently assigned to the hotkey, if any. Only assign the hotkey if you don't mind overriding this command.

- 8 Set the Direction option. If you choose Press, Maya runs the command when you press the key down. If you choose Release, Maya runs the command when you let the key up.

The distinction between Press and Release can be important, for example when you assign a hotkey to a snapping mode. You want to assign the command that turns the snapping mode *on* to the key *press*, and the command that turns the snapping mode *off* to the key *release*.

- 9 Click Assign.

If the hotkey you set already has a command assigned, Maya asks if you want to override it.

Related topics

- ❖ "Assign a marking menu to a hotkey" on page 281

7 | Preferences and customization

How do I? > View a list of all assigned hotkeys

- ❖ "Assign a predefined command to a hotkey" on page 284
- ❖ "View a list of all assigned hotkeys" on page 286
- ❖ "Hotkey editor" on page 329

View a list of all assigned hotkeys

- 1 Choose Window > Settings/Preferences > Hotkeys.
- 2 Click List All.

Related topics

- ❖ "Assign a marking menu to a hotkey" on page 281
- ❖ "Assign a MEL script to a hotkey" on page 285
- ❖ "Hotkey editor" on page 329

Customize how Maya works

Load or unload plug-ins

A plug-in is an add-on module that extends Maya's capabilities. File translators are plug-ins you use to import and export various file formats. You can create or purchase specialty plug-ins to customize Maya for a specific job.

Some features that can be added through plug-ins are:

- File translators for new file formats.
- New tools, menu items, and MEL commands.
- New object types (nodes).
- Drivers for new devices.

To load or unload plug-ins

- 1 Choose Window > Settings/Preferences > Plug-In Manager.
- 2 Do any of the following:
 - Check the "loaded" box next to a plug-in to load the plug-in.
 - Check the "auto load" box next to a plug-in to always load the plug-in when Maya starts up.
 - Click the "i" icon next to a plug-in to show additional information about the plug-in, for example the version number and any MEL commands it adds to Maya.

7 | Preferences and customization

How do I? > Improve performance, quality, or interactivity

Note You cannot load a plug-in for any version of Maya that predates the Maya version the plug-in was compiled for. For example, you cannot use a plug-in compiled with the Maya 5 API in Maya 4.

Check the “For API Version” number in the plug-in’s information window.

To force Maya to unload a plug-in being used in the current scene

If you try to unload a plug-in that is providing functionality in the current scene (for example, the scene contains a node type that is provided by the plug-in), Maya warns you and gives you the opportunity to force the removal of the plug-in.

If you choose to force Maya to unload the plug-in, Maya converts any nodes in the scene provided by the plug-in to the “Unknown” node type. Even if you reload the plug-in, the nodes remain Unknown.

Related topics

- ❖ “Supported file formats” on page 215
- ❖ “Plug-in Manager” on page 331

Improve performance, quality, or interactivity

Use the settings in Window > Settings/Preferences > Performance Settings to choose trade-offs between quality and performance.

Related topics

- ❖ “Window > Settings/Preferences > Performance Settings” on page 298

Switch between Y-up and Z-up

- 1 Choose Window > Settings/Preferences > Preferences.
- 2 Under World Coordinate System, click Y or Z.

Related topics

- ❖ “3D coordinates” on page 37

7 | Preferences and customization

How do I? > Customize the Maya Help

Customize the Maya Help

Customize the Maya Help

You can customize the look and feel of the Maya Help by modifying settings on the Maya Help Preferences page.

Note You must load the preference page from the Help Server (not by clicking on preferences.html in the help directory), and have cookies enabled in your browser to save settings. Settings only apply to the specific browser they are saved in; otherwise, you'll see the default view of the Maya Help.

To switch between dual pane and single pane search results

- 1 In the Maya Help navigation (left-hand) frame, expand Developer Resources and click Customize the Maya Help.
- 2 In Search - Results View, click the Tabs or Dual Pane radio button.
- 3 Click Save Settings.

To change the number of hits per page displayed in the search

- 1 In the Maya Help navigation (left-hand) frame, expand Developer Resources and click Customize the Maya Help.
- 2 In Searching - Default Hits per Page, change the value using the drop-down menu.
- 3 Click Save Settings.

To switch which navigation folder to auto-expand

- 1 In the Maya Help navigation (left-hand) frame, expand Developer Resources and click Customize the Maya Help.
- 2 In Navigation - Folder to auto-expand, choose which folder you want to expand when you load the Help for the first time or click Home.
- 3 Click Save Settings.

To show or hide Quick Links (developer links) on the home page

- 1 In the Maya Help navigation (left-hand) frame, expand Developer Resources and click Customize the Maya Help.
- 2 In Homepage - Show quick links, click the on or off radio button
- 3 Click Save Settings.

Customize the Maya Web browser

Customize the Maya Web browser

You can customize the Maya Web browser to handle files of various types (including Flash, Shockwave, etc.), by adding the appropriate Mozilla plug-in to the following directory:

`<Maya directory>/bin/plugins`

On Mac OS X, there are standard places where all the internet plug-ins go:

- `/Library/Internet Plug-Ins/` (these plug-ins are accessible by all users on this system)
- `~/Library/Internet Plug-Ins/` (these plug-ins are accessible by current user only)

In some cases, you'll be able to drop a Mozilla-compatible plug-in directly into that directory. Some installers will create the plug-in in a different directory, such as the one for the Netscape or Mozilla Web browsers. You'll have to copy that plug-in from the plug-in directory of Mozilla or Netscape to the directory listed above, and then restart Maya to get the plug-in functionality in the Maya Web browser.

Advanced customization

Directly modify the settings files

Maya stores preferences files in the following path:

- Windows: `<drive>:\Documents and Settings\\My Documents\maya\\prefs`
- Mac OS X: `~/Library/Preferences/Alias/maya/<version>/prefs`
- IRIX/Linux: `~/maya/<version>/prefs`.

Most preferences are saved as text files of MEL commands.

Shelves are stored in the shelves subdirectory, icons are stored in the icons subdirectory, and marking menus are stored in the markingMenus subdirectory.

When you customize Maya, your new settings are stored in user preference files, so that each time you open Maya, your settings are used instead of the Maya default settings. If you delete a preference file, Maya uses the default settings.

7 | Preferences and customization

How do I? > Directly modify the settings files

Note Maya does not detect if you are out of space if your disk overflows while Maya is saving preferences. If this occurs, your preferences may become corrupt or irretrievable. Ensure that your hard drive has space available to save your Maya preference files. If the disk runs out of space, free up some space before exiting the Maya application.

Color and hotkey files

The following .mel files store settings you have customized using the Colors window and Hotkey Editor.

- userColors.mel – Contains preferences defined on the Active and Inactive tabs of the Colors window.
- userRGBColors.mel – Contains preferences defined on the General tab of the Colors window.
- paletteColors.mel – Defines the colors (RGB) making up the index palette in the Active and Inactive tabs of the Colors window.
- userHotkeys.mel – Contains any hotkeys you have assigned in the Hotkey Editor window.
- userNamedCommands.mel – Contains all the commands that have hotkeys assigned to them.

Default hotbox marking menus

The following files define the default Hotbox marking menus.

- menu_ChangePanelLayout.mel – North
- menu_ChangePanelType.mel – South
- menu_ChangeSelectionMask.mel – West
- menu_CommonModelingPanels.mel – Center
- menu_ControlPaneVisibility.mel – East

User preferences

The following files define user preferences.

- userPrefs.mel – Contains preferences defined in the Preferences window (Window > Settings/Preferences > Preferences).
- windowPrefs.mel – Defines the default size and position of Maya windows.

7 | Preferences and customization

How do I? > Run MEL commands whenever Maya starts up

Run MEL commands whenever Maya starts up

Maya runs any commands in the `userSetup.mel` file whenever it starts up. You can use this file to set up your working environment or execute commonly used MEL commands like aliasing.

The scene is created *after* `userSetup.mel` runs, so you cannot use `userSetup.mel` to create objects.

To run a certain set of MEL commands every time Maya starts up

- 1 Create a file named `userSetup.mel` in the following folder:
 - Windows: `<drive>:\Documents and Settings\<username>\My Documents\maya\<Version>\scripts`
 - Mac: `~/Library/Preferences/Alias/maya/<version>/scripts.`
 - IRIX/Linux: `~/maya/<version>/scripts.`(where `~` is your home folder)
- 2 In the `userSetup.mel` file, type the commands you want to Maya to run on start up.

Run MEL commands whenever a scene is opened or closed

A script node lets you attach a MEL script to a scene, and have the script run whenever the scene is opened (loaded from disk) or closed (when the user opens another scene file or starts a new scene).

Refer to the MEL and expressions guide for information on script nodes.

For more information, search the online help for Script Nodes

Create a custom heads-up display readout

Use the `headsUpDisplay` MEL command to create or edit a custom readout in the heads-up display.

The following explains the basics of using the command. Read the `headsUpDisplay` command documentation in the online help for a full explanation of the command's usage and flags.

Related topics

- ❖ "Show information over top of a view (heads-up display)" on page 63

7 | Preferences and customization

How do I? > Create a custom heads-up display readout

Ingredients

Procedure

Create a MEL procedure that returns the information you want to show in the heads-up display.

Update event

Decide when Maya needs to update the display item. For example, if your display item shows some information about the selected object, Maya only needs to change it when the selection changes. This is the *event* that triggers a display update.

Maya has a number of events you can listen for. Use `headsUpDisplay - listEvents` to see the list of all events.

If you update on a selection-based event (“SelectionChanged” or “SomethingSelected”), you can refine the event listening to only fire on a specific type of change to the selected nodes using the `-nodeChanges` flag.

`-nodeChanges "attributeChange"` fires when any attribute on a selected node changes.

`-nodeChanges "connectionChange"` fires when any input or output on a selected node changes.

`-nodeChanges "instanceChange"` fires when any selected instanced node changes.

Section and block position

Choose a column for the item to appear in. This is called the *section*. The following chart shows the number the command uses to refer to each column. 0 is the upper-left corner, 9 is the bottom-right corner of the screen.

0	1	2	3	4
5	6	7	8	9

Choose a line within the section on which the display item appear. This is called the *block*.

Label

Choose the label that appears before the information on the display line, for example “Position:”.

7 | Preferences and customization

How do I? > Create a custom heads-up display readout

The command

To create a heads-up display item:

```
headsUpDisplay
    -section          <section number>
    -block            <block number>
    -label            "<label>"
    -command          "<procedure()>"
    -event            "<event>"
    <object name>;
```

Then, to show the item:

```
headsUpDisplay -edit -visability 1 <object name>;
```

Or to hide the item:

```
headsUpDisplay -edit -visability 0 <object name>;
```

See the example below.

The command has many more options than are described here, especially for changing the appearance of the display item and checking the usage of blocks. Read the `headsUpDisplay` command documentation for more information.

Make the change permanent

Add the commands that create the heads-up display item (and any associated user interface) to `userSetup.mel` to have them permanently added to your copy of Maya.

Example

For example, if you want to show the XYZ coordinates of the selected object in the heads-up display, create a MEL procedure (for example, `objectPosition()`) that returns the XYZ coordinates of the selected object.

`objectPosition` procedure

```
global proc float[] objectPosition ()
{
    string $selectedNodes[] = `selectedNodes`;
    float $position[3];
    if (size($selectedNodes) > 0)
    {
        string $mainObject = $selectedNodes[ (size($selectedNodes) - 1) ];
        $position[0] = `getAttr $mainObject.translateX`;
        $position[1] = `getAttr $mainObject.translateY`;
        $position[2] = `getAttr $mainObject.translateZ`;
    }
    else
    {
```

7 | Preferences and customization

How do I? > Create a custom heads-up display readout

```
        $position[0] = 0;
        $position[1] = 0;
        $position[2] = 0;
    }
    return $position;
}
```

headsUpDisplay command

Then use the `headsUpDisplay` command to create the heads-up display object, and add a user interface to turn the display item on or off.

```
// Create custom HUD objects
// To create a script like this for testing, see the command documentation
// for the headsUpDisplay command.
//
headsUpDisplay
    -section          4
    -block            5
    -label            "Position:"
    -command          "objectPosition()"
    -event            "SelectionChanged"
    -nodeChanges     "attributeChange"
    HUDObjectPosition;

// Add menu items to control the custom items
//
global string $gHeadsUpDisplayMenu;

// Add a divider to separate Maya items from custom items
menuItem -parent $gHeadsUpDisplayMenu -divider true;

// Add one menu item per heads up display object created above
//
menuItem -parent $gHeadsUpDisplayMenu
    -checkBox true
    -label "Object Position"
    -command "headsUpDisplay -e -vis 1 HUDObjectPosition"
    -annotation "Object Postion: Toggle the display of object position" \
    myObjectPostionItem;
```

Reference Hotkeys

View hotkeys

Hold + drag	Function
Alt + the left mouse button	Tumble.
Alt + the middle mouse button	Track.
Alt + the right mouse button or Alt + the left and middle mouse buttons	Dolly.

Press	Function
a	Show all.
f	Show selected.

Press	Function
1	Rough display.
2	Medium display.
3	Smooth display.

Press	Function
4	Wireframe display.
5	Shaded display.
6	Shaded and textured display.
7	Display with lights.

7 | Preferences and customization

Reference > Tool and action hotkeys

Press	Function
Ctrl+Space	Switches between the standard view and a full-screen view.
Alt+B	Changes the background color of the perspective and orthographic panels: standard (light gray), dark gray, or black.

Related topics

- ❖ "Create or edit a marking menu" on page 280
- ❖ "Assign a predefined command to a hotkey" on page 284
- ❖ "View a list of all assigned hotkeys" on page 286

Tool and action hotkeys

Press	Function
q	Select tool.
w	Move tool.
e	Rotate tool.
r	Scale tool.
t	Show Manipulator tool.
y	Last tool used.
+ -	Change the size of the manipulator.

Press	Function
z	Undo.
Shift + z	Redo.
g	Repeat last action.

7 | Preferences and customization

Reference > Tool and action hotkeys

Press	Function
F8	Toggle object/component selection mode.
p	Parent.
Shift + p	Unparent.
s	Set key.
Shift + w	Key the selected object position.
Shift + e	Key the selected object rotation.
Shift + r	Key the selected object scale.

Press	Function
8	Paint effects panel.
ctrl + a	Attribute editor.

Hold	Function
x	Snap to grid.
c	Snap to curve.
v	Snap to point.

Related topics

- ❖ "Create or edit a marking menu" on page 280
- ❖ "Assign a predefined command to a hotkey" on page 284
- ❖ "View a list of all assigned hotkeys" on page 286

7 | Preferences and customization

Reference > Window > Settings/Preferences > Preferences

Menus

Window

Window > Settings/Preferences > Preferences

Shows the Preferences window.

❖ "Preferences" on page 303

Window > Settings/Preferences > Colors

The Colors window has three tabs. Each tab allows you to change the default colors for a different set of components.

Related topics

❖ "Change user interface colors" on page 273

Options

General tab

Use the General tab to change the default colors for components in these areas: 3D Views, User Defined, Ghosts, Heads Up Display, Animation, Animation Editors, Multilister, Hypergraph / Hypershade, Outliner, and Trax Editor.

Active tab

Use the Active tab to change the default colors for components in these areas: General, Objects, Components, Deformers, Manipulators, Animation, and Artisan Brushes.

Inactive tab

Use the Inactive tab to set the colors for objects that are not selected. The Inactive tab lets you change the default colors in the following areas or tools: General, Modeling, Objects, Components, Deformers, and Animation.

Window > Settings/Preferences > Performance Settings

Lets you choose trade-offs between performance and quality, as well as temporarily disable some visual updates to improve interactivity.

7 | Preferences and customization

Reference > Window > Settings/Preferences > Performance Settings

Options

Screen refresh options

To set when to refresh (or redraw the screen) when manipulating objects, in the Dependency Graph Evaluation section, select one of the following:

Drag

Refreshes the display during the drag.

Demand

Refreshes the display only when you release the mouse button and click the Refresh button that appears in the bottom right of the display window.

Release

Refreshes the display only when you release the mouse button.

Controlling complex operations on surfaces

To control complex operations on surfaces during mouse interaction, in the Surfaces section, select one of the following beside the surface:

On

Performs complex operations during mouse interactions.

Off

Completely disables complex operations during mouse interaction.

Interactive

Suspends complex operations during mouse interaction.

Controlling complex operations on deformers

To control complex operations on deformers during mouse interaction, in the Deformers section, select one of the following beside the surface:

On

Performs complex operations during mouse interactions.

Off

Completely disables complex operations during mouse interaction.

Interactive

Suspends complex operations during mouse interaction.

7 | Preferences and customization

Reference > Window > Settings/Preferences > Shelves

Per Node

For Cluster Resolution and Lattice Resolution only, improves redraw performance for individual cluster or lattice deformations by setting the Use Partial Resolution attribute to partial and setting the Percent Resolution on a per node basis. For details, see Character Setup.

Global

For Cluster Resolution and Lattice Resolution only, improves the redraw performance of *all* cluster or lattice deformations. (You do not need to set the Percent Resolution for each cluster or lattice.)

Set Global Cluster Resolution and Global Lattice Resolution to Full, High, Medium, or Low. A Low setting corresponds to a low percentage, and therefore more improved performance.

For more information on surfaces, see NURBS and Polygonal modeling. For more information on deferrers, see Character Setup.

Window > Settings/Preferences > Shelves

The shelf editor provides a dialog box with which you can create and edit shelves.

Related topics

- ❖ "Shelves" on page 22
- ❖ "Choose actions on a shelf" on page 27
- ❖ "Add a tool, action, or MEL script to a shelf" on page 277
- ❖ "Edit the contents of a shelf" on page 278
- ❖ "Use a custom name or icon for a shelf item" on page 279
- ❖ "Change the display of shelves" on page 279

Tabs and controls

Shelves

Click the Shelves tab to display existing shelves. From here you can create, delete, and rename shelves and change their order.

Shelf Contents

Click the Shelf Contents tab to display the contents of a specific shelf. From here you can move and delete shelf items, change an item's label and tooltip, as well as change its icon and icon name.

7 | Preferences and customization

Reference > Window > Settings/Preferences > Shelves

Edit Commands

Click the Edit Commands tab to view and edit the MEL code associated with a tool or action.

Label & Tooltips

Specify a brief description of the tool. This description appears with the icon in the icon or text modes, as well as in the tooltip (the pop-up description when the mouse hovers over the icon).

Icon Name

Type a label for the icon. This text appears on top of the icon to distinguish it from other items that use the same icon. Note that the icon name always appears on top of the icon, unlike the label, which you can specify to show or hide.

Change Image

Click this button to change the icon image.

Save All Shelves

Click Save All Shelves to save all changes immediately and write the information to the user shelves directory. The file name for a shelf file has the prefix *shelf_*.

Close

Click Close to accept your changes but not write them to the disk immediately. If your UI preference is to save shelf changes only when explicitly requested, the changes stay in effect only for the current session. Otherwise your changes are saved the next time you save a file or quit the application.

Options menu

Icon Only

Displays only the icon. This is the default.

Icon/Text Below

Displays the label below the icon.

Icon/Text Beside

Displays the label beside the icon.

Save Automatically

When this option is on, your changes to the shelves are saved when you exit Maya. This is the default.

7 | Preferences and customization

Reference > Window > Settings/Preferences > Marking Menus

Save Only on Request

When this option is on, your changes to the shelves are only saved when you select Save All Shelves in the Shelves window. If you don't save your changes, then they are lost when you exit Maya.

Window > Settings/Preferences > Marking Menus

Shows the Marking menus editor.

- ❖ "Marking Menus editor" on page 325

Window > Settings/Preferences > Panels

Shows the panel editor. This is the same as selecting Panels > Panel Editor in a panel.

- ❖ "Panel editor" on page 93

Window > View Arrangement, Saved Layouts

Let you choose a layout and layout/contents presets. These are the same as the layouts/presets available using the quick layout buttons or the Panels menu in a panel.

- ❖ "Quick layout buttons" on page 69
- ❖ "Panels menu" on page 90

Windows and Editors

Hotbox

Hotbox Controls > Hotbox Style

Controls what controls are available in the hotbox. The hotbox appears when you hold down the space bar.

Related topics

- ❖ "Customize the hotbox" on page 283

Menu

Zones and Menu Rows

Make all of the menu rows visible.

Zones Only

Display just the five marking menu zones. Menu sets are not available.

Center Zone Only

Make only the center zone (Alias) active everywhere. North, South, East, and West Zones and menu sets are not available.

Center Zone RMB Popups

Turn this option on to display menus for the selected menu set when you right-click on the workspace. The menu set appears as a pop-up instead of a row. Note that the functional menu sets do not display when this option is on, even if you have selected to show them.

Windows and editors

Preferences

Interface

Menu Set

This determines which menu set displays in the main Maya menu bar on start-up. The default is Animation.

Show Menubar

Hides or displays the main menu bar (Windows, Linux, and IRIX only) and the Panels menu bar.

Show Title Bar

Hides or displays the title bars in the main window and the Script Editor (Windows, Linux, and IRIX only). The title bar includes window control buttons for expanding and collapsing the application.

Windows

Turn on Remember Size and Position so that Maya restores the size and position of all windows when closed and re-opened. If turned off, the Maya windows always display in the center of the screen upon opening.

Command Line

Turn on Hold Focus if you want the cursor to stay in the Command Line after you press Enter (Windows, Linux, and IRIX) or Return (Mac OS X). Otherwise, the cursor returns to the current window.

7 | Preferences and customization

Reference > Preferences

Open Attribute Editor

Use this option to specify how the Attribute Editor displays when you open it (such as pressing Ctrl+a (Windows, Linux, and IRIX) or Command+a (Mac OS X)). To open the Attribute Editor in a separate window, select In Separate Window. To open the Attribute Editor in the main Maya window, select In Main Maya Window. By default, the Attribute Editor opens in Maya's main window.

Open Tool Settings

Use this option to specify how the Tool Settings display when you open them. To open the Tool Settings in a separate window, select In Separate Window. To open the Tool Settings in the main Maya window, select In Main Maya Window. By default, the Tool Settings window opens in Maya's main window.

Expression Editor

Select an Expression Editor for editing text.

UI Elements

Visible UI Elements

Hides or displays UI elements. You can also control this display from the Display > UI Elements menu.

Turns on any elements you want displayed in the Maya main window.

Editor in Main Window

You can choose to show or hide the Editor. The Editor can be one of the Attribute Editor, Tool Settings, or Channel Box/Layer Editor. You can also control this display from the Display > UI Elements menu or the three icons on the far right of the Status Line.

Panel Configurations

When Saving

When Save Panel Layouts with File is turned on, the panel layouts are saved with the scene file. The default is on. (This replaces the former Save File options.)

Tip Turn this option off when making objects/sub-scenes to use as referenced files. By default, Maya remembers everything about every editor you've opened, such as location, size, window-specific options, etc., in every scene file (.ma/.mb). This is saved as a attribute on a script node named *uiConfigurationScriptNode* that displays as MEL code added into a node's string-valued attributes.

When Opening

When turned on, this restores saved layouts from the file. The default is on. (This replaces the former Open File options.)

Starting New Scenes

You can specify a layout for new scenes.

**Keep Current
Layout**

Keeps the current layout for new scenes.

**Use Layout
Specified
Below**

Creates new scenes based on the layout selected from the drop-down menu. Single Perspective View is the default.

Help

Popup Help

Display Time

Specify a display time for pop-up help. The default is four seconds.

Help Browser

Open Help

You can choose to open the Maya documentation within Maya (in the Maya browser) or in an external Web browser (set by your system's file association with .html).

Help Language

Sets which documentation language set Maya loads when you use the help. If you have another documentation language set installed you can click Other and type a language/dialect code in the Specify language box.

7 | Preferences and customization

Reference > Preferences

Help Location

Local	Maya displays online help from its own help server. Maya starts the server when Maya launches and stop the server when Maya quits.
Remote	Maya displays online help from the URL in the URL box. This can be a help server running on the network.

If you change the setting from Remote to Local, quit and restart Maya to get Maya to start up the local help server.

Display

Performance

Fast Interaction

Turns Fast Interaction on to improve performance by displaying fewer geometric entities (such as polygons). The default is off.

Viewport textures

You can set the slider to display viewport textures in a trade-off between fast and high quality.

- | |
|---|
| <p>Notes</p> <ul style="list-style-type: none">• If the scene has only hardware textures, this slider has no effect.• The scene's textures are not automatically updated with any changes; you'll need to force an update; for example, by reloading the scene.• The only textures affected are the ones set to use the default texture quality but whose 2d texture placement options are not handled in hardware (for example, use stagger or some other option the card/drivers don't support in hardware). |
|---|

View

Axes

Displays one or both of the XYZ coordinates (view and origin axes). If you disable both choices, no XYZ coordinates appear.

View Axis	Displays the XYZ coordinates in the bottom left corner of the view. The default is on.
Origin Axis	Displays the XYZ coordinates at coordinates 0, 0, 0. The default is off.

Grid Plane

Displays or hides the grid plane. The grid is a 2D plane that represents 3D dimensions in the view. It is useful when you want to animate motion relative to a solid surface. Select Hide to hide the grid. The default is Show.

This setting overrides the Display > Grid setting.

Active Object Pivots

Specify whether to display pivot points. The default is off.

Affected Highlighting

Turns highlighting display on or off. An object associated with or affected by a selected object is highlighted in a different color. The default is on.

Note You can edit this highlight color by selecting Window > Settings/Preferences > Colors, clicking the Active tab, expanding General, and modifying Active Affected.

Wireframe on Shaded

Select how you want to display the wireframe on shaded objects.

Full	Displays normal resolution wireframes on shaded objects. This is the default.
Reduced	Displays fewer wires on shaded objects.
None	Displays no wires on shaded objects. Performance is enhanced if you select None.

Region of Effect

This option lets you turn on or off the region of effect display. Region of effect is the part of an object that potentially changes as a result of moving selected CVs. Note that curves show the region of effect as well as surfaces. The default is on.

7 | Preferences and customization

Reference > Preferences

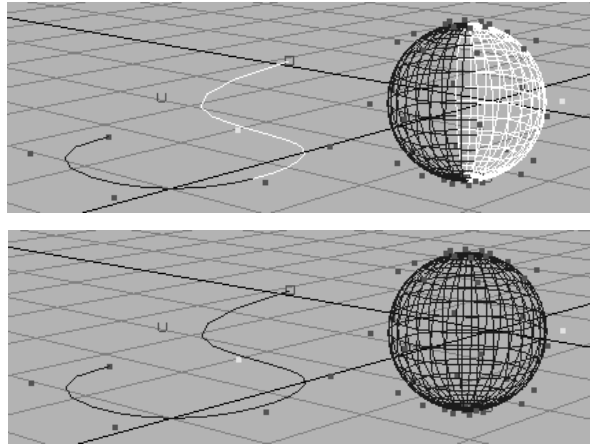

Shade Templates

If on, template objects appear shaded in shaded view. If off, the templated objects appear as wireframes while all other objects appear shaded. The default is off.

Kinematics

Joint Size

Changes the display size of skeleton joint sizes. The range is from 0.01 to 5.0.

IK/FK Joint Size

For skeletons with blended IK/FK animation, this option sets the display size for the joints and bones in your IK and FK skeletons. This option does not affect the display size of the joints and bones in the IK/FK Blend skeleton.

IK Handle Size

Changes the display size of IK handles. The range is from 0.01 to 5.0.

Ik/Fk Blending Display

For skeletons with blended IK/FK animation, this option specifies which skeletons appear in the scene view.

None	Only the IK/FK Blend skeleton appears in the scene view.
IK	Only the IK skeleton appears in the scene view.
FK	Only the FK skeleton appear in the scene view.
Both	The FK, IK, and IK/FK Blend skeletons appear in the scene view.

7 | Preferences and customization

Reference > Preferences

Note By default, joints and bones appear dark navy blue. But when a skeleton has both IK and FK, each skeleton appears as a different color (FK is Black, IK is a Dark Red/Brown, and Blend appears pink/magenta).

Animation

Ghosts

Steps before Current Frame

Specifies how many ghosted images are drawn at frames before the current frame. Type a value or drag the slider. The default is 3.

Steps after Current Frame

Specifies how many ghosted images are drawn at frames after the current frame. Type a value or drag the slider. The default is 3.

Frames Per Step

Specifies the number of frames between drawing the ghosts. Type a value or drag the slider. The default is 1.

Manipulators

Global Scale

Specifies the size of the manipulators. The range is from 0.10 to 10.00.

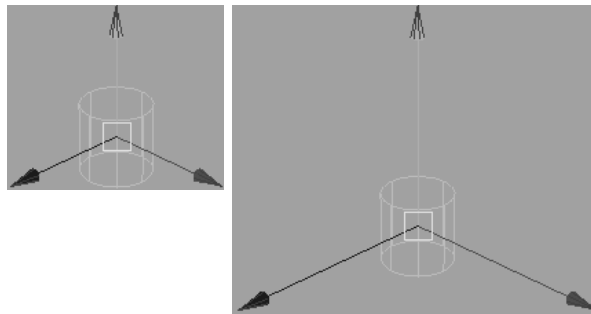

Handle Size

Specifies the size of the handle. The range is from 4 to 100.

7 | Preferences and customization

Reference > Preferences

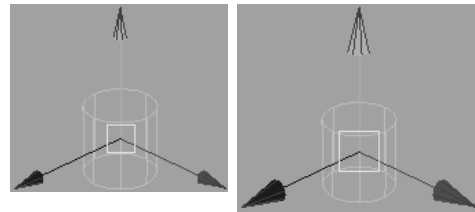

Line Size

Specifies the line thickness size of the rotate manipulator's rings.

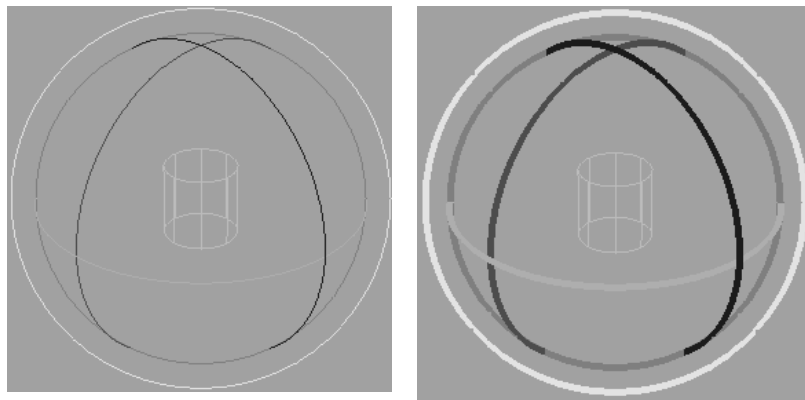

Line Pick Size

Determines the line thickness used when *picking* the rotate manipulator rings. The pick size should be the same as line size, so you can identify which handle will be picked by the size of the ring.

Previous State Size

Controls the size of the points drawn for a previous feedback. For example, for the Move Tool, an axis is drawn to indicate the previous position, with square points at the end of the axes. This controls the size of the squares.

Rotate and scale manipulators also have previous state feedback. This type of feedback is shown only when you drag; it disappears as soon as you release the mouse.

Default Manipulator

You can specify a *Default Manipulator* option in the Show Manipulator section to control what manipulator, if any, appears when you select the Show Manipulator Tool. The Default Manipulator options include:

- | | |
|-----------|---------------------------------------|
| None | Does not display a manipulator. |
| Translate | Displays the Move Tool's manipulator. |

Rotate	Displays the Rotate Tool's manipulator.
Scale	Displays the Scale Tool's manipulator.
Transform	Displays the Transform (triple) manipulator.
Smart	Checks the first child and if it is a shape displays the history manipulator for the shape. Otherwise displays the Transform (triple) manipulator. This is the default.

NURBS

New Curves, New Surfaces

Select whether you want Edit Points, Hulls, CVs, or origins on new curves or new surfaces:

Note These options work only on new curves or surfaces, not existing items.

Surface Divisions

Controls the smoothness of an object in a view. It also affects the rendering of newly created surfaces. Enter a value or use the slider. The range is from 0 to 64. The higher the value, the smoother the surface.

Curve Divisions

Controls the smoothness of a curve in a view. Enter a value or use the slider. The range is from 1 to 128. The higher the value, the smoother the curve.

Shaded Divisions

Controls how smooth your smooth-shaded object looks. Enter a value or use the slider. The range is from 1 to 64. The higher the value, the smoother the smooth-shaded object.

Polygons

Vertices

Specify how you want vertices to display:

Display	Turns the display of vertices on or off.
Normals	Displays vertex normals on or off.
Backculling	Makes vertices invisible in areas where the normal is pointing away from the camera.

7 | Preferences and customization

Reference > Preferences

Edges

Specify how you want edges to display:

- | | |
|-----------|--|
| Standard | Displays all edges the same (hard or soft). |
| Soft/Hard | Displays soft edges as dotted lines and hard edges as solid lines. |
| Only Hard | Displays hard edges only (makes soft invisible). |

Highlight

Specify how you want to highlight polygons:

- | | |
|-----------------|--|
| Border Edges | Displays thicker outside edges to make them more visible for certain operations. |
| Texture Borders | Displays a thick border to highlight the area a texture affects per polygon or per vertex. |

Border Width

Specify the width of the polygon border. The range is from 1 to 10.

Faces

Specify how you want faces to display:

- | | |
|------------|---|
| Centers | Displays a small square to indicate the face center. |
| Normals | Shows the normals at the center of each polygon. |
| Triangles | Displays all polygons as triangles. |
| Non-planar | Displays non-planar faces with a tinted color for easy identification. A non-planar face has vertices that lie outside the plane of the face. By identifying and eliminating non-planar faces, you can avoid unexpected results from reshaping the surface later. |

Show Item Numbers

Specify where you want item numbers displayed: at each vertex (Vertices), at each edge (Edges), on each face (Faces), or at each UV (UVs).

Normals Size

Specifies the display size of the normals. The range is from 0.1 to 10.

Color

Turn Colored Shading on to use the Apply Color operation (Edit Polygons > Colors > Apply Color).

Color Material

These menu options override any existing material channels and replace them with the vertex colors you assign. For all options other than None, lighting affects the object's shading.

None	None of the material properties of the shader(s) assigned to the object are used. In this case lighting is also disabled.
Ambient	The ambient material channel of the assigned shader(s) is overridden by the vertex color.
Ambient + Diffuse	The ambient and diffuse material channels of the assigned shader(s) are overridden by the vertex color.
Diffuse	The diffuse material channel of the assigned shader(s) is overridden by the vertex color.
Specular	The specular material channel of the assigned shader(s) is overridden by the vertex color.
Emission	The emission material channel of the assigned shader(s) is overridden by the vertex color.

Material Blend

Renders material blends in hardware. For details of how Material Blend operates, see **Color per vertex now supported by hardware renderer**.

Backface Culling

Specify the display for backface culling:

Off	No backface culling occurs. This is the default.
On	Surfaces become invisible in areas where the normal is pointing away from the camera.
Keep Wire	Displays wireframe outlines, but any areas where the normal is pointing away from the camera are hidden.
Keep Hard Edges	Sets backface culling for soft edges only. See Polygonal Modeling for more information on polygonal modeling.

7 | Preferences and customization

Reference > Preferences

Settings

Up Axis

Sets the up axis to Y or Z. The default is Y.

Linear

Sets the unit of measure for operations that use linear values, for example, moving and scaling. The default is centimeters.

Angular

Sets the unit of measure for operations that use an angular value, for example, rotation. The default unit is degrees.

Time

Sets Maya's internal representation of what one "second" is. For example, in a dynamics simulation, which relies on real world timings, the resulting simulation produces keys which represent one second as 24 frames (Maya's default value).

It also allows you to compensate for intermediate output devices (for example, Abekas, etc.) which may have different frame rates to your final output (for example, Film). When changed, your animation keys move in time to match that range. This is only while your time units are on that alternate setting. Returning the time units to your creation setting returns your keys to their original location.

The default for measuring time is Film 24fps (24 frames per second).

Note Be sure you set your preferred time unit for a particular session, **before** creating any animation. This ensures correct timing of your keyframes, for the final output and final fps setting.

Keep Keys at Current Frames

By default when you change the current time unit, the times for any existing keys are modified so that playback timing is preserved. For example, a key set at frame 12film changes to frame 15ntsc when the current time unit is changed to NTSC, since they both represent a key at 0.5 seconds. When this option is on, it leaves the key at 12ntsc that was originally at 12film. The default setting for this option is off. The option turns on once the current time unit is changed.

Tolerance

The Tolerance value determines the degree of accuracy that is maintained between the original and fit (or interpolated) curves. This setting applies globally to Maya. You can change it on a case-by-case basis. Set the following tolerance options:

- | | |
|------------|---|
| Positional | Set the degree of accuracy between the actual positions of the original and interpolated curves. |
| Tangential | Set the degree of accuracy required to determine if two NURBS objects are to be made tangent across a shared edge or point. |

Cameras

Default Cameras

Sets the default Near Clip and Far Clip values for cameras. For more information, see **Clipping planes**.

Dynamics

Auto Create Rigid Body

Turn this option on to automatically create active rigid bodies when you connect an object to a field (apply a field's influence to geometry).

Run Up to Current Time

If you click a frame in the Time Slider, the correct state of all dynamic objects in the scene is displayed only if Maya performs run-up to calculate each frame prior to that frame. Turn this option on if you want to click frames in the Time Slider. Note that run-up also occurs for hidden objects.

Leave run-up turned off if you want to prevent Maya from calculating dynamics when you click in the Time Slider. This is useful in a scene that has both nondynamic objects and complex dynamic objects, where you want the state of nondynamic objects to appear promptly after you click the Time Slider. If you are keying dynamic objects, it's also useful leave run-up turned off to avoid waiting for run-up calculations that are irrelevant to your keying activities.

Run Up From

Select one of the following options:

- | | |
|---------------|--|
| Previous Time | If you click a frame higher than the current frame, run-up starts from the prior current time and ends at the frame you click. Select this option if you won't be changing any attributes of a dynamic object in the scene. This setting lessens the time you'll spend |
|---------------|--|

7 | Preferences and customization

Reference > Preferences

waiting for run-up. If you click a frame lower than the current frame, run-up starts from the beginning of the animation.

Start Time Run-up starts from the start frame regardless of where you click in the Time Slider. Select this option if you plan to change any attributes of a dynamic object in the scene. This ensures that you see the correct object states when you click in the Time Slider after modifying an object's dynamics.

Save Startup Cache for Particles

When this option is turned on (the default), Maya automatically saves the start-up cache for all your particles every time you save the file. Unlike particle disk caches, you don't have to create the start-up cache explicitly every time. See Dynamics for more information.

Echo Collision Commands

When you have a particle collision MEL callback specified, every time a collision happens, Maya echoes the command that it is running, then runs it. In a scene with thousands of particles, that produces a great deal of unnecessary output to the Script Editor. This preference enables and disables echoing of the collision commands before they are run.

Files/Projects

Default Projects Directory, Always Start in This Project

Use these settings to set up a default projects directory when you create new projects and on startup.

Files, Increments, Projects

Specify how many files, increments, and projects you want to have listed in each of the File > Recent submenus.

Ascii File Compression Mode

On File Save

Specify the compression mode you want to use when saving an ASCII file:

Compressed Saves files in compressed mode. File compression reduces the sizes of large files so they do not occupy as much space on your hard drive.

Uncompressed Saves files in uncompressed mode.

7 | Preferences and customization

Reference > Preferences

As Is	Keeps files in their original compression mode rather than compressing or decompressing them. As Is is the default.
-------	---

Note To use compression modes, please ensure that a zip utility is installed and in the path on your machine.

Display Layer

File Import Merge

Specify how you want the Display Layer merged when you import a file.

None	All layers read in are put in a new layer, renumbered, and renamed, if necessary to preserve uniqueness.
By Number	Rather than creating a new layer, all layers read in that have the same index number as an existing layer are merged with that layer.
By Name	Rather than creating a new layer, all layers read in that have the same name as an existing layer are merged with that layer.

Keys

Auto Key

Turn Auto Key on to automatically set keys on keyable attributes of an animated object (including lights, shaders, textures, cameras, and so on). You can choose to key modified attributes or all attributes.

New Curve Default

Use this menu to create blends between rotations using quaternions rather than Euler angles.

Weighted Tangents

Turn Weighted Tangents on to give animation curve tangents weight. The default is turned off, which means the tangents are non-weighted.

Default In Tangent, Default Out Tangent

Set the default In and Out Tangents to:

Spline	Creates an animation curve that is smooth between the key before and the key after the selected key.
Linear	Creates an animation curve as a straight line joining two keys.

7 | Preferences and customization

Reference > Preferences

Clamped	Creates an animation curve which has the characteristics of linear and spline curves.
Flat	Sets the in and out tangents of the key to be horizontal (with a slope of 0 degrees).
Stepped	Creates an animation curve whose out tangent is a flat curve.

Modeling

Output Geometry as

These settings determine the type of geometry created from modeling actions such as Revolve, Loft, Extrude, Fillet Blend, and so forth. Setting it here affects all applicable modeling actions. Otherwise, select Mixed to use the individual settings of each modeling action.

NURBS Interaction: Interaction Mode

Specify whether you want certain NURBS modeling commands to behave like actions or tools. An action performs a discrete function on selected objects. A tool lets you manipulate objects until you complete the operation. You may want to change actions to tools as you become proficient at Maya's NURBS modeling.

To globally change the applicable modeling tools, choose Everything is a Tool or Everything is an Action. To individually set each command, choose Mixed.

Rendering

Preferred Renderer

You can choose your preferred renderer. This is the renderer that Maya resets to when you create a new scene (File > New Scene) or when you start Maya. This can be one of Maya Software, Maya Hardware, Maya Vector (if loaded), or mental ray (if loaded).

Selection

Modifiers

Modifiers control Maya selection operations. They work with masks to control what is displayed when you select items. You can turn on one or more of the following:

Single Marquee Select

Selects the first object in a hierarchy.

Click Drag Select

Lets you perform one-step click-dragging with the transformation tools. You can move one object using the Move tool, then click on a second object and the Move tool displays. This means you do not have to select the object and the Move tool again—you can keep using the Move tool on any subsequent selected object. The default is off.

Affects Active

If you change from object to component selection mode, the selected object is not affected. This option lets you select objects and components at the same time. The default is on.

Popup Menu Selection

When objects overlap in the view, lets you display a pop-up list of the objects so you can select them. Left-click on the overlap area to display the menu. The default is off. Your selection is highlighted in the scene view as you select an item in this list. Currently-selected items are marked with a box when the list appears.

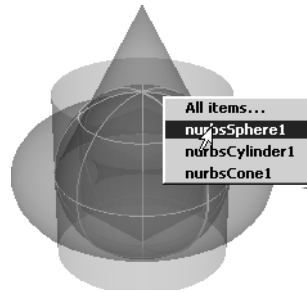

Note You must hold down the left mouse key on Linux and IRIX to select an item in this list.

Ignore Selection Priority

Treats all objects with the same priority. The selection order does not matter. The default is off.

Expand Popup List

If you turned on Expand Popup List, displays all the pop-up list of objects and everything underneath it in the hierarchy. The default is off.

7 | Preferences and customization

Reference > Preferences

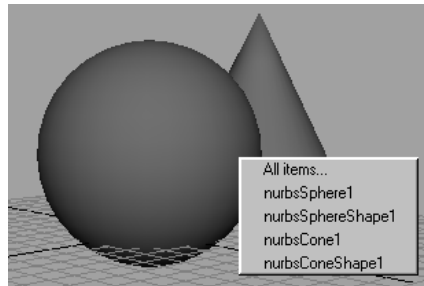

Click Box Size

This option controls the size of the selection area around the mouse pointer, or *click box*. If you are having problems with selecting objects or components, try adjusting this option. For example, a higher click box size might make it easier to select curves. Increasing the click box size is also useful if you have a high resolution screen display.

Polygon Selection

Select Faces with

Specify how you want to select polygonal faces:

- Center** Select polygonal faces at their center. In other words, you must click the box at the center of the face to select the entire face.
- Whole Face** Select the entire face. You can click anywhere on the face, even any face edge, to select it.

Priority

You can specify a selection priority for objects and components. By default, NURBS curves have a higher selection priority than surfaces. This means that Maya selects the NURBS curve before the surface when you select geometry that contains both NURBS curves and surfaces.

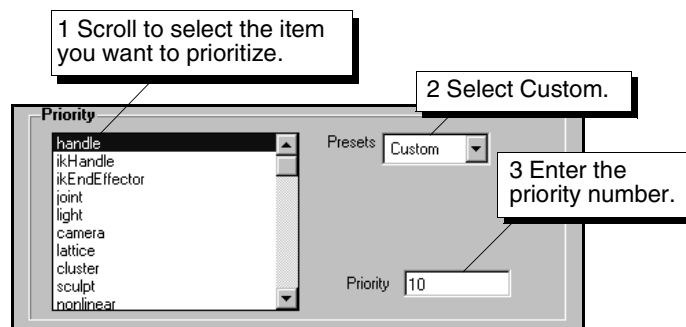

Snapping

With these options, you can control the size region around the mouse pointer that is used for the snap operation.

Use Snap Tolerance

When on, the snap region is restricted to a square area around the cursor, defined by the Snap Tolerance option. When off, the snap region is unlimited; you can snap to anything viewable.

Snap Tolerance

Controls the size of the snapping area around the cursor when Use Snap Tolerance is on. For example, if you have two curves close together and you try snapping to one of the curves, the object may snap to the wrong curve. To avoid this, try using a small Snap Tolerance value.

UV Texture Editor Snapping

UV Snap Tolerance

This preference defines how close UVs are together before they snap when moving and using the v hotkey (snap to points).

Edge Snapping

Snap Magnets

Controls the number of magnet points inside edges. For example, 3 means there are magnet points at each end and in the middle.

Magnet Tolerance

Controls how “sticky” each magnet is; that is, how close the point must be to a magnet before the point snaps to it. Set this to 100 to constrain points to always be at magnet points.

Sound

Waveform Display

The Waveform Display option allows you to control how much of the sound’s waveform is displayed.

Top Displays only the top half of the sound.

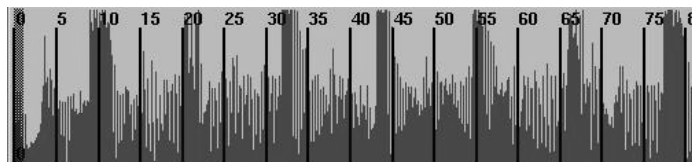

7 | Preferences and customization

Reference > Preferences

Bottom Displays only the bottom half of the sound.

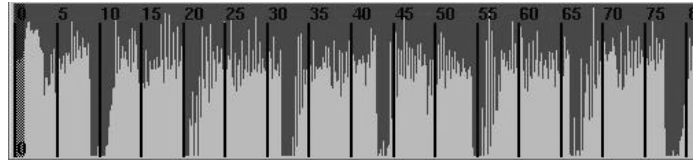

All Displays the full waveform.

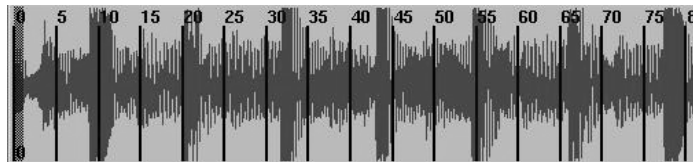

Repeat on Hold

Repeats a sound at the current time. You must hold the mouse button down in the Time Slider. For more information on using sound with Maya, see *Animation*.

Repeat Size

Controls how much sound (in the current time unit) is repeated when you turn on Repeat on Hold.

Timeline

Playback Start/End

Specifies the range of time to use as your time playback range.

Animation Start/End

Displays the entire range of times available.

Height

Adjusts the height of the time slider. This helps with sound syncing (as a soundtrack can be displayed in the time slider). Select 1x for the default size, 2x to double the size of the slider, and 4x to quadruple the size of the slider.

Key Ticks

Keyframe ticks show the location of keys along the time slider. Select None to turn the key tick display off, Active to display only active keys, or Channel Box to display only those keys in the Channel Box.

Options

Turn the following options on or off:

7 | Preferences and customization

Reference > Preferences

Timecode	Changes the default display of time to video standard timecode. Enables the Timecode Offset box so you can supply timecodes to match the timing from videotape.
Snapping	Turns key snapping on or off. When on, the time indicator shows integer values only.

Timecode Offset

The Timecode Offset lets you specify how time 0 on the Time Slider appears when displaying in Timecode mode. For example, if the Timecode Offset is set to three hours (a value of 03:00:00:00), the Timecode Display would read 03:00:00:00 at time 0.

Playback

Update View

Specifies whether Maya plays back an animation in All modeling views or only in the active view. The default is Active.

Looping

Specifies how you want Maya to play back an animation. Select Once to play an animation once, then stop. Select Oscillate to play an animation forwards and backwards continuously. Select Continuous to play an animation continuously. Continuous is the default setting.

Playback Speed

Specifies the frame rate for playback.

Play every frame	Displays all the frames of your animation. Each frame is updated completely before proceeding to the next one. Specify the exact rate in the Playback by box. This rate reflects your system's ability to draw your animation on screen and is not necessarily a real-time playback mode. This is the default setting.
Real-time (24 fps)	Plays your animation in real-time. Some frames may be dropped (not displayed) to execute this in real-time. This depends on your system's capabilities, the complexity of your scenes, and the display mode for the playback.
Half (12 fps)	Plays back at exactly half the speed of real time.
Twice (48 fps)	Plays back at twice real-time speed.

7 | Preferences and customization

Reference > Preferences

Other Enables the Other box so you can enter an exact ratio of playback rate to real-time.

Playback by

If you select Play every frame for the Playback Speed, specify the exact rate in this box. This rate reflects your system's ability to draw you animation on screen and is not necessarily a real-time playback mode. The default setting is 1.0.

Undo

Undo

Select On if you want to be able to undo operations. This is the default.

Queue

Select Infinite to perform an unlimited number of undo operations. This option can use a lot of memory. Select Finite to limit the number of undo operations you can perform (specified in the Queue Size box). The default is Finite.

Queue Size

If Finite is the selected Queue setting, specify here the number of undo operations you can perform. The default is 50.

Web browser: Network and User settings

Home page

Sets the home page that the Maya browser goes to on launch or when you click the Home button.

Font size

Set the variable and fixed font sizes in pixels.

General

Set the web browser to resize images to fit the browser window, or to display them full-size.

Network Configuration

You can choose from Direct Connection, Manual Proxy (enter the URLs and port numbers of the HTTP, SSL, and FTP proxies), or Automatic Proxy (enter the configuration URL). You can also set the Web browser to bypass the proxy server(s) for specified URLs.

Modules

Maya includes a number of different software modules. Each time you start Maya, the software loads all the available licensed modules.

Loading several modules can use a lot of RAM and thus increase the start-up time. To avoid this, you can disable one or more of the modules. You can still load a disabled module by selecting it from the main menu bar.

You can also disable various modules based on the specific tasks you are performing. For example, if you are only rendering, you can improve system response time by disabling Dynamics.

Marking Menus editor

Lets you edit the available marking menus. Once you define a marking menu, you must assign it to a hotkey or add it to the hotbox before you can use it.

Related topics

- ❖ "Create or edit a marking menu" on page 280
- ❖ "Assign a marking menu to a hotkey" on page 281
- ❖ "Add a marking menu to the hotbox" on page 282

7 | Preferences and customization

Reference > Marking Menu editor

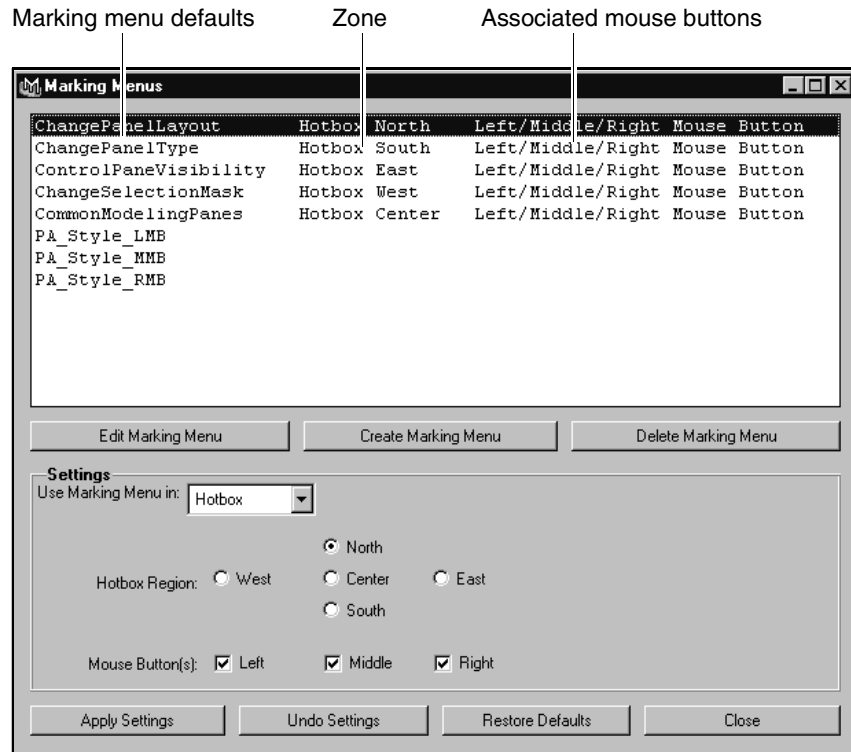

Marking menu editor

Use Marking Menu in

Specify whether the marking menu is linked to the Hotbox or a hotkey.

Hotbox Region

If you selected Hotbox for Use Marking Menu in, select the Hotbox zone the marking menu occupies: North, South, East, West, or Center.

Mouse Button(s)

Select the left, middle, or right mouse button used to display the marking menu. You can select one, two, or three mouse buttons.

Marking menu item editor

Label

Enter the name of the marking menu item.

Icon Filename

Enter the name of the icon file. For more information, see MEL and Expressions.

7 | Preferences and customization

Reference > Marking Menus editor

Command(s)

Enter the MEL script used as the command for the menu item. You can drag the MEL script from the Script Editor's bottom panel with the middle mouse button.

Check Box

Displays a check box beside the marking menu item.

Radio Button

Displays a check box beside the marking menu item.

Neither

Displays nothing beside the marking menu item.

Option Box

Turn Option Box on to display the option box beside the menu item so you can change a tool's options from the marking menu.

Note If the tool or action does not have an options window, you must use MEL code to create the box. Once the box is created, you must write MEL code to invoke the option window. For more information on MEL commands, see MEL and Expressions.

Option Box Command(s)

Enter the MEL script to use as the command for the menu item's option box.

Assign hotkey area

Key

Enter the key you want to assign to the selected command. Enter a letter from A to Z (upper and lower case are different keys) or a number from 0 to 9. You cannot use more than one letter or number.

Or, choose a special key from the pull-down list. For example, if you want the right arrow key to act as the trigger, assign it here.

Modifier

Select either Alt (Windows, Linux, and IRIX)/Option (Mac OS X) or Ctrl or Command (Mac OS X) for the hotkey modifier.

7 | Preferences and customization

Reference > Marking Menus editor

Direction

Use Press or Release to associate a command with the press or a release of a key. For example, you can create a hotkey to instruct Maya to snap to a curve when you press a key, then turn off the snapping when you release it.

If you added a key to an operation ending with (Press) or (Release), add the same key to the corresponding (Release) or (Press) operation.

Add to Recent Command List

Turn on so that this hotkey can appear in the Edit > Recent Commands window.

Query

Click Query to determine whether the specified key settings have already been assigned to a command.

Find

Click Find to highlight the category and command for the key you enter in the Key field.

List All window

No Modifiers

Lists only single hotkeys, without Ctrl or Alt (Windows, Linux, and IRIX) or Option (Mac OS X).

Ctrl or Control

Lists only hotkeys with a Ctrl-key combination.

Alt or Option

Lists only hotkeys with an Alt or Option-key combination.

Command

Lists only hotkeys with a Command + key combination. Available for Mac OS X only.

List All

Lists all hotkeys.

Ignore Release

Turn on to ignore the hotkeys that activate when you release the key, versus when you press the key. Turn off to see all hotkeys, including the ones activated when you release the key.

Hotkey editor

Lets you assign predefined commands, MEL scripts, or marking menus to keys and key combinations.

Related topics

- ❖ "Assign a marking menu to a hotkey" on page 281
- ❖ "Assign a predefined command to a hotkey" on page 284
- ❖ "Assign a MEL script to a hotkey" on page 285
- ❖ "View a list of all assigned hotkeys" on page 286

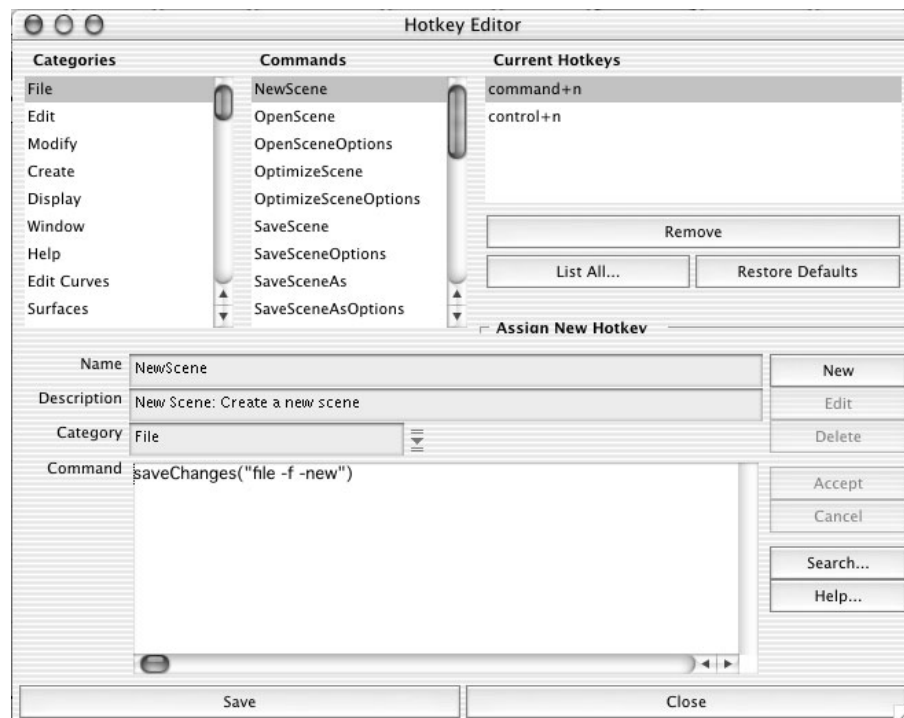

Windows > Settings/Preferences > Hotkeys

Categories and Commands

Maya includes a large number of useful pre-defined hotkey commands. You can use these commands instead of writing your own MEL script.

Click a category in the Categories list to see the list of available pre-defined Commands in the category.

Click a command in the Commands list to see its current hotkey(s) or assign it to a new key.

7 | Preferences and customization

Reference > Hotkey editor

Current hotkeys

List box

Shows all hotkeys that active the selected command.

Remove

Select a hotkey and click Remove to unassign the hotkey.

List All

Opens a window listing every assigned hotkey and its command.

Restore Defaults

Returns all hotkey assignments to their “factory defaults” (the original commands they were assigned to when Maya was installed).

Assign New Hotkey

Key

Type a keyboard symbol in the text box, or use the pull-down list next to the text box to select other keys.

If you type an upper-case letter in the text box, Maya requires you to type the letter with the shift key to activate the hotkey.

Modifier

Choose a modifier to add to the key.

Direction

Choose when the command activates: when you press the key down, or when you let the key back up (release).

Add to Recent Commands List

Choose whether Maya should add the command to the Recent Commands list (Edit > Recent Commands) when you activate the hotkey.

Edit area

New

Create a new user-defined command which you can then assign to a hotkey.

Edit

Edit the selected user-defined command in the Commands list.

Delete

Delete the selected user-defined command in the Commands list.

Name

The name of the selected command.

Description

A description of the command's purpose and effect.

Category

The category in which the command appears (in the Categories list box).

Command

The script that runs when the command is activated.

Accept

Click to save the command you are creating or editing. This button is only available after you click New or Edit to create or edit a command.

Cancel

Click to cancel editing a command. This button is only available after you click New or Edit to create or edit a command.

Search

Lets you search for text in the name or script of all defined commands. Use asterisks as wildcards.

Plug-in Manager

A plug-in is an add-on module that extends Maya's capabilities. File translators are plug-ins you use to import and export various file formats. You can create or purchase specialty plug-ins to customize Maya for a specific job.

Some features that can be added through plug-ins are:

- file translators
- tools
- objects (nodes)
- MEL commands
- device drivers

Related topics

- ❖ "Supported file formats" on page 215
- ❖ "Load or unload plug-ins" on page 286

7 | Preferences and customization

Reference > Plug-in Manager

Windows > Settings/Preferences > Plug-in Manager

The Plug-in Manager identifies which plug-ins are loaded into Maya. If you have a plug-in that you use frequently, you can make sure it is always there. The Plug-in Manager automatically scans all the directories in the plug-in path and lists available plug-in features.

loaded

Turn on loaded to load the plug-in for the current Maya session.

auto load

Turn on auto load to load the plug-in so that the next time you start Maya the plug-in loads automatically.

Information window

To view information about a particular plug-in, you must first load it, then click the **i** button beside the plug-in.

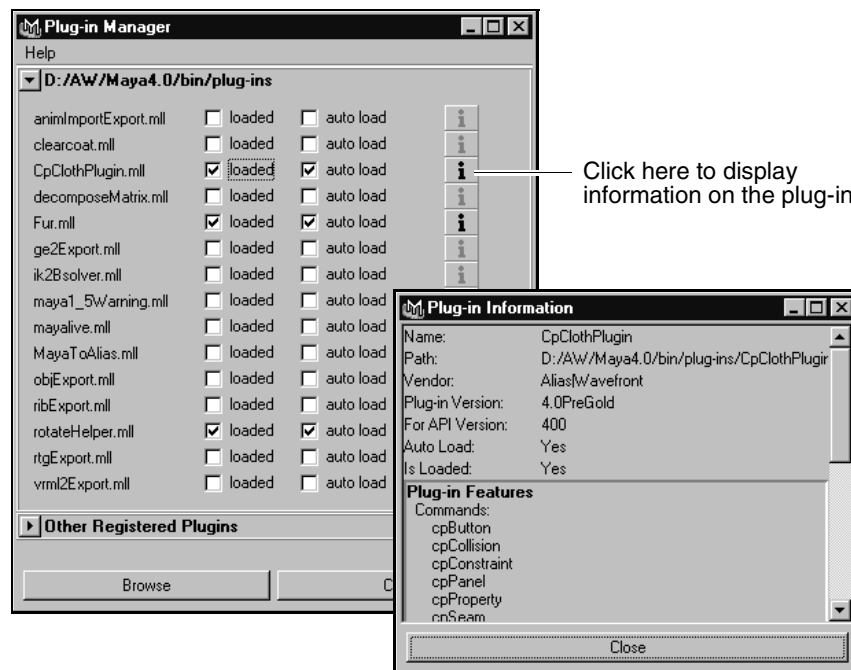

Maya displays the following information for a selected plug-in:

Name

The name of the plug-in. On Linux and IRIX, plug-ins have the extension *.so*. On Windows, they have the extension *.mll*. On Mac OS X, the extension is *.lib*.

7 | Preferences and customization

Reference > Plug-in Manager

Path

The location of the file. On Linux and IRIX, the default plug-in location is:

```
/usr/aw/maya6/bin/plugin
```

On Windows, the default plug-in location is:

```
drive:\Program Files\Alias\Maya6.0\bin\plugin
```

On Mac OS X, the default location is

```
/Applications/Alias/Maya6/Application Support/plugin
```

Vendor

The manufacturer of the plug-in.

Plug-in Version

The version number of the plug-in.

For API Version

The version of the Maya API (Application Programmer Interface) the plug-in was compiled for.

Note You cannot load a plug-in for any version of Maya that predates the version it was compiled for.

Auto Load

Indicates whether the plug-in has been marked for auto load.

Is Loaded

Indicates whether the plug-in is loaded.

Plug-in Features

Displays a list of the features added by the plug-in (for example, commands, dependency nodes, file translators).

To display additional plug-ins, click the triangle to open the Other Registered Plug-ins section.

7 | Preferences and customization

Reference > Plug-in Manager

Index

Numerics

- 3D coordinates, about 16
- 3D Paint Texture options 236

A

- absolute numeric input 36
- accessing Maya browser 31
- actions
 - about 17
 - using 25
- Add Attribute (Modify menu) 180
- Add Instance
 - when parenting 179
- Add to Current Selection brush option 54
- Affects Active option. 319
- align objects. 117
- animated nodes 208
- animation
 - continuous play option. 323
 - curves
 - using to create falloff138
 - details, Heads Up Display 72
 - key options 317
 - markers, hiding 75
 - oscillating 323
 - playback options 323
 - Start/End option 322
 - transitions (of view) 209
- annotate objects 230
- Annotation (Create menu) 252
- Apply Current to All option. 89
- arc-length values, show. 231
- Attribute Editor
 - about 189
 - loading attributes into. 190
- attribute spread sheet
 - interface. 195
 - viewing multiple attributes 162

- attributes
 - Attribute Editor 190
 - connect input and output 172
 - customize 166
 - description 149
 - filter information 176
 - general, for nodes 268
 - ignoring when rendering 192
 - keyable 151
 - lock value 166
 - open multiple editors 167
 - presets 164
 - use full names 237
 - view and edit 159

- Auto Key
 - animation option 317
- Autom Create Rigid Body dynamics option 315
- auxiliary nodes 157
- axes
 - choosing for transformations. 114
 - orientation 130
 - rotation order. 130
- azimuth
 - control with mouse 59
 - description 84

B

- Back (Maya Browser) 39
- backfaces
 - culling, display options 313
 - displaying and hiding. 76
- Background Color attribute
 - Environment attributes. 100
- Based on distance option 137, 138
- blend box for colors 263
- Bounding Box
 - Dolly camera setting 83
 - option 87
- bounding volumes of objects 258

Index

- browser
 - accessing 31
 - controls 39
 - MEL commands 39
- browser in a panel 22
- buttons
 - File 34
 - quick layout 69
 - Render 36
 - Sidebar 36
 - snapping 35
- C**
- Camera Settings (View menu) 78
- Camera Tools (View menu) 80
- Camera/Light Manipulator (Display menu) 77
- cameras
 - aperture 97
 - azimuth 84
 - center of interest 77, 83
 - Center of Interest option 102
 - clipping planes 77
 - control which one is shown 62
 - cycling index 77
 - elevation 84
 - field chart 79
 - fill 80
 - film gate 79
 - frustrum 79
 - gate 79
 - hiding 74
 - horizontal 80
 - journal 78
 - manipulators, hiding 75
 - node 97
 - overscan 80
 - perspective 78
 - pitch 84
 - resolution gate 79
 - revolving 80
 - revolving about center of interest 83
 - rolling 83
 - safe action 79
 - safe title 80
 - tracking 81
 - yaw 84
 - zooming 83
- Center of Interest
 - about 102
 - displaying 77
 - option 77
- Center Pivot (Modify menu) 144
- center the view 59
- Change Precision 146
- Channel Box 196
 - colors 199
- Channel Control
 - option 197
- Channels 132
- Check Box option 327
- check boxes in marking menus 327
- Clamped animation option 317
- Click Box Size option 320
- clipping planes, displaying 77
- Closest Visible Depth, Depth Type 100
- cloth
 - hiding 74
- collapsing shapes
 - in Hypergraph 211
- Color editor 262
- Color Index Mode option (IRIX) 88
- Color Shading option 312
- color wheel 262

colors	
change	273
change wireframe	68
Channel Box	199
display wireframe	75
Hypergraph, changing	211
set palette	264
value	263
Colors window tabs	298
command line	37
focus, default	303
options	29
Command(s) option	327
commands	
assign to hotkeys	284
edit completed	121
repeat	121
complex	
manipulators	109
models, displaying	87
Component Display (Display menu)	75
component editor	
editing numeric values	125
interface	145
Component Use Object Pivot	130, 131
components	
about	17
numeric values, edit directly	125
selecting	45
selection mode	319
show isolated subset	67
show or hide	65
compression mode	316
cone angle of light, displaying	77
configuring Maya browser	32
connection lines	
in dependency graph	206
connections	
direction of	206
lines in dependency graph	206
of nodes, show	171
construction history	105
about	150
edit	121
construction plane	
about	106
snapping creation tools	117
Construction Plane (Create menu)	144
continuous play option	323
Control Points	132
coordinate systems	104
copies of objects	106
Copy	
geometry type	133
crash, recover data from	224
Create menu	
Annotation	252
Construction Plane	144
Empty Group	253
Locator	252
Measure Tools	252
Sets	253
Text	144
Create Reference (File menu)	245
culling	
display options	313
Curve Divisions option	311
curves	
interpolated, setting tolerance	315
modification falloff	138
new, display options	311
NURBS	138
show parameter or arc-length values	231
smoothness, controlling	311
snapping to	35
text type	144
custom attributes	
reserved names	193
CVs	
displaying on new curves or surfaces	311
hiding	74
select region of	51
selecting	53
cycling index	
of cameras	77
of light	78

Index

D

- DAG view
 - connection lines 210
- data, recover after a crash 224
- Decay Regions of light, displaying 77
- Default In/Out Tangent animation options 317
- Default scene 232
- default shelves, load 28
- deformers
 - complex operations, controlling 299
 - hiding 74
- Degree option 137
- Delete (Edit menu) 131
- Delete All by Type (Edit menu) 132
- Delete Attribute (Modify menu) 185
- Delete by Type (Edit menu) 132
- delete objects 123
- dependency graph 105
 - about 153
 - displaying lights 205
 - displaying textures 205
 - materials 205
 - shading groups 205
 - show inputs and outputs 171
- dependency view 152
- Depth attribute
 - Output Settings attributes 100
- depth file
 - description, for cameras 100
- Depth Of Field attribute 98
- Depth Type
 - Furthest Visible Depth 100
 - Output Settings attributes 100
- Depth Type, Closest Visible Depth 100
- DG node display 210
- direct manipulation 150
- directory
 - setting default 316
- Discrete Move 128
- Discrete Rotate 130
- Discrete Scale 131
- disk cache options 236
- Display Field Chart attribute 102
- Display Film Gate attribute 101
- display layers 226
 - import options 317
 - index number 317
- Display menu
 - Camera/Light Manipulator 77
 - Component Display 75
 - Grid 69
 - Heads Up Display 71
 - Hide 73
 - Object Display 75
 - Show 73
 - UI Elements 41
 - Wireframe Color 75
- display of objects
 - change 63
- Display Options attributes
 - cameras 101
- display performance
 - improving 87
- Display Resolution attribute 101
- Display Safe Action attribute 102
- Display Safe Title attribute 102
- Display Time 305
- displaying
 - input and output connections 207
 - objects as semi-transparent 87
- Distance Cutoff option 137
- Dolly
 - about 57
 - Bounding Box camera setting 83
 - camera settings 82
 - Local camera setting 82
 - Snap box dolly to camera settings 82
 - Surface camera setting 82
- Don't Ignore when Rendering option 192
- Driven Channels 132
- Duplicate (Edit menu) 133
- Duplicate command 106
- Duplicate Input Connections 134
- Duplicate Input Graph 134
- Duplicate with Transform 134
- Duplicate with Transform (Edit menu) 135

duplicating objects 124
 dynamics
 rigid bodies, options 315

E

edges
 display options. 311, 313
 hard, displaying. 312
 soft 312
 Edit Attribute (Modify menu) 184
 Edit menu
 Delete. 131
 Delete All by Type. 132
 Delete by Type 132
 Duplicate. 133
 Duplicate with Transform 135
 Group 248
 Invert Selection 52
 Level of Detail 250
 Paint Selection Tool. 53
 Parent 178
 Quick Select Sets 53
 Select All 52
 Select All by Type 53
 Select Hierarchy. 52, 178
 Ungroup 249
 Unparent. 179
 edit points
 displaying on new curves or surfaces 311
 editors
 Attribute 189
 Attribute Spread Sheet 195
 attribute, open multiple 167
 Channel Box 196
 Color 262
 Component 145
 component 125
 hotkey 329
 Hypergraph 155, 202

Layer 256
 Outliner. 154, 185
 Panel 93
 plug-in manager 331
 Relationship 259
 shelf 276
 Visor 265
 elevation
 control with mouse 59
 description, for azimuth elevation tool 84
 Empty Group (Create menu) 253
 Enable Default Scene. 231
 Environment attributes. 100
 EPS file import 240
 Evaluate Nodes (Modify menu) 179
 exact transformation values, typing 111
 Expand Popup List modifier option 319
 Export All (File menu). 242
 export objects to a new file 222
 Export Selection (File menu) 242
 expressions
 connect attributes with. 173
 external file, import or reference data from. 220
 eyedropper tool 263

F

F Stop attribute. 98
 faces
 display options. 312
 snap to center 129
 factory settings, resetting 25, 26
 falloff
 curve modification 138
 linear modification 137
 power modification. 137
 script modification 137
 Field Chart option 79
 File buttons 34

Index

- File menu
 - Create Reference 245
 - Export All 242
 - Export Selection 242
 - Import 237
 - New Scene 231
 - Open Scene 232
 - Optimize Scene Size 237
 - Project 247
 - Reference Editor 247
 - Save Scene 234
 - Save Scene As 235
 - File Type option 232
 - files
 - formats, supported 215
 - setting default projects directory 316
 - Fill option 80
 - Film Aspect Ratio attribute 98
 - Film Back attributes 97
 - Film Gate attribute 97
 - Film Gate option 79
 - Film Offset attribute 98
 - Flat animation option 317
 - Flat Shade options 87
 - flip objects 114
 - focal length of camera, changing 83
 - Focus Distance attribute 98
 - Focus Region Scale attribute 99
 - focus, command line 303
 - Font
 - text object 144
 - font size, Web browser 324
 - Forward (Maya browser) 39
 - Frame All in All Views (Window menu) 78
 - frame rate
 - Heads Up Display 72
 - playback 323
 - Frame Selection in All Views (Window menu) . . . 78
 - Free playback option 323
 - free-form layout mode 210
 - Freeze Transformations (Modify menu) 139
 - frustrum 79
 - renderable 79
 - Furthest Visible Depth
 - Depth Type 100
- ## G
- gate of camera 79
 - geometric primitives, creating 122
 - geometry
 - hiding 74
 - type 133
 - Gimbal rotate mode 129
 - global rotate mode 129
 - graphs
 - rebuilding 209
 - graphs, large
 - improve performance 211
 - grid
 - show, hide, change 63
 - snapping to 35
 - Grid (Display menu) 69
 - Grid (Show menu) 86
 - Group (Edit menu) 248
 - group objects 227
 - Group Pivot 249
 - Group Under 249
 - Group under 133
 - groups
 - nodes 153
- ## H
- Half (12 fps) playback option 323
 - handles
 - size, specifying 309
 - hard edges
 - displaying 312
 - Hardware Fog option 89
 - Hardware Texturing option 89
 - Heads Up Display (Display menu) 71
 - heads-up display 63
 - customize readout 291
 - Height animation option 322

- help
 - get. 24
- Help Browser 305
- Help Language 305
- Help Location 306
- hidden nodes 157
- Hide (Display menu). 73
- hierarchy
 - of nodes, view and change. 168
 - parenting. 153
 - select objects by 50
 - view 152
- Hold Focus command line option. 303
- Home (Maya browser) 39
- Home page 324
- horizontal layout of graph 206
- Horizontal option. 80
- hotbox
 - add marking menus 282
 - choose actions 27
 - controls 302
 - customize 283
 - default files. 290
- hotkeys
 - assign command 284
 - assign marking menus 281
 - assign MEL script 285
 - assigning areas. 327
 - editor, about. 329
 - list. 20
 - tumble, track, dolly 57
 - view list. 286
- HSV color model 263
- hulls
 - displaying on new curves or surfaces 311
- Hypergraph 202
 - change the visual layout of nodes. 170
 - changing default colors. 211
 - collapsing shapes in 211
 - deleting connections 211
 - IK Handle Tool. 211
 - window. 155
- I**
 - Icon Filename option. 326
- icons
 - create for shelves 279
- Ignore
 - when Rendering option 192
- Ignore Selection Priority modifier option 319
- IK handles
 - display size, setting. 308
- Illustrator file import. 240
- Image attribute
 - Output Settings 99
- Image Plane attribute
 - Environment attributes. 101
- Import (File menu). 237
- importing
 - data from external file. 220
 - merging layers. 259
- improving speed, Hypergraph 210
- In Tangents, default. 317
- Information window, for plug-ins 332
- Inherits Transform attribute. 269
- input
 - absolute. 36
 - box 36
 - connections. 207
 - nodes 206
 - relative. 36
- Instance Leaf Nodes 135
- instances
 - create 133
 - objects, copying, instancing 106
- interactive
 - display 88
- Interactive Shading option. 88
- interactivity, improve 287
- interface for Maya 15
- interpolated curves
 - tolerance, setting 315
- Invert Selection (Edit menu). 52
- Isolate Select (Show menu). 85
- isolated subset of objects or components, show in a panel 67

Index

J

- joints
 - display size, setting 308
- Journal Command attribute 102
- Journal option 78

K

- Key Ticks option 322
- keyable attributes 151
- keys
 - options 317
- kinematics
 - hiding 74

L

- Label option 326
- Lasso tool 37
- lattices
 - points, displaying and hiding 76
 - shape, displaying and hiding 76
- Layer editor 256
- layers
 - display 213
 - editing relationships 259
 - import merge options 317
 - index number 317
 - merge options 259
 - organize objects 226
- layout
 - customize 274
 - edit 93
 - saved 92
- Layouts option 92
- Level of Detail (Edit menu) 250
- Lighting menu 89

lights

- barn doors 77
- center of interest 77
- cone angle 77
- cycling index 78
- decay regions 77
- dependency graph 205
- hiding 74
- linking 259
- manipulators, hiding and showing 75
- penumbra 77
- pivot 77

linear

- animation option 317
- modification falloff 137

lines

- thickness, manipulators 309
- Load All References 233
- Load No References 233
- Load Selected Components 146
- loading references 256

local

- dolly camera setting 82
- rotate mode 129
- rotation axes, displaying and hiding 76
- space 104
- space, Move tool 127
- Locator (Create menu) 252
- lock value of an attribute 166
- Locked
 - Tumble camera setting 81
- Look through Barn Doors option 77
- Look Through Selected 91
- Looping animation option 323

M

- main window 18
- Make Live (Modify menu) 41

manipulators	
camera, hiding	75
customize	122
handles, displaying and hiding	77
light, hiding	75
lock to the current selection	110
move	127
Move tool	128
rotate	129
scale	130
show	38
show or hide in the Channel Box	161
thickness	309
using	107
manipulators, about	150
markers	
hiding animation	75
marking menus	
about	21
add to hotbox	282
assign to hotkeys	281
customize	280
displaying checkboxes	327
displaying radio buttons	327
mask	
description, for cameras	99
output settings attributes	99
materials dependency graph	205
Maya	
interface, about	15
Maya browser	22
accessing	31
configuring	32
controls	39
MEL commands	39
measure	
distance between points	230
Measure Tools (Create menu)	252
MEL commands	
add to shelf	277
adding to marking menu	327
start-up	291
MEL commands in Maya browser	39
MEL scripts	
adding to marking menu	327
assign to hotkey	285
propMod script	137, 139
MEL, about	151
Menu set menu	34
menu_ChangePanelLayout.mel	290
menu_ChangePanelType.mel	290
menu_ChangeSelectionMask.mel	290
menu_CommonModelingPanels.mel	290
menu_ControlPaneVisibility.mel	290
menus	
about	20
add to shelf	277
Lighting	89
Menu set	34
Panels	90
Shading	86
using	25
merging display layers	259, 317
models, complex	87
Modify menu	
Add Attribute	180
Center Pivot	144
Delete Attribute	185
Edit Attribute	184
Evaluate Nodes	179
Freeze Transformations	139
Make Live	41
Prefix Hierarchy Names	179
Reset Transformations	139
Snap Align Objects	140
Transformation Tools	135
modules	
options	325
mouse	
use to control camera	59
Move Objects	
when parenting	178
move objects	110
Move tool	127
coordinate system	127
move, in increments	128

Index

multiple attribute editors 167
multiple nodes, selecting 210

N

namespaces 238, 246
network configuration, Web browser 324
network settings, Web browser 324
New Curves option 311
New Group
 create for instances 134
New Scene (File menu) 231
New Surfaces option 311
No Gate option 78
Node Display Override Color 170
nodes
 animated 208
 attribute names in dependency graph 207, 208
 camera 97
 change the order 171
 containing param curves 208
 customize manipulator 122
 description 149
 general attributes 268
 group 153
 hidden 203
 hierarchy, view and change 168
 input 206
 output 206
 script, execute 233
 set update state 174
 show and hide 175
 show connections 171
 slanted boxes 208
 types 157
 use full names 237
 visual layout 170
Normal (24 fps) playback option 323
Normals
 Freeze Transformations option 140
normals
 change display 275
 size on polygons 312
Number of Copies 133

numeric
 input 36
 values, edit directly 125

NURBS

curves, using to create falloff 138
CVs, select region of 52
display options 311

O

Object Display (Display menu) 75
object space 104
objects
 about 17
 align 117
 annotate 230
 bounding volumes 258
 change name 224
 change the look 63
 change wireframe color 68
 deleting 123
 duplicating 124
 export to new file 222
 filter information 176
 group 227
 make unselectable (template) 225
 move, rotate, scale 110
 organize on display layers 226
 parenting 153
 selecting 45
 selection mode 319
 show isolated subset 67
 show or hide 64
 smoothness, controlling 311
 snapping 119
 space coordinate system, Move tool 127
 viewing more than one at the same time 251
Only for non-rigid deformations 140
Open (Maya browser) 39
Open Help 305
Open Help In Main Maya Window 33
Open Help Using External Browser 33
Open Scene (File menu) 232
Optimize Scene Size (File menu) 237
origin, about 16

Basics

344

- Ortho step
 - Tumble camera setting 81
 - Orthographic views
 - Attribute Editor, cameras 102
 - camera settings 81
 - Oscillate animation option 323
 - Out Tangents, default 317
 - Outliner editor 154, 185
 - output
 - connections 207
 - nodes 206
 - Output Settings attributes 99
 - Overscan option 80
- P**
- packages
 - options 325
 - paint files, browsing with Visor 265
 - Paint Selection Tool (Edit menu) 53
 - painting
 - select components by 50
 - palette of colors 264
 - paletteColors.mel 290
 - pan the view 57
 - panel
 - Web browser 22
 - Panel option 91
 - panels
 - add 275
 - add layout to shelf 277
 - deleting 275
 - editor 93
 - layout, change 60
 - layout, customize 274
 - tear off as window 62
 - Panels menu 90, 91
 - param curves 208
 - parameter values, show 231
 - Parent 133
 - Parent (Edit menu) 178
 - parent node 105
 - Parent to World, unparenting 179
 - parenting objects 153
 - partial curve manipulators 109
 - partitions
 - about 214
 - editing 259
 - grouping sets 228
 - path of preferences files 289
 - penumbra of light, displaying 77
 - performance
 - improving 287
 - options 298
 - Perspective option 78
 - pitch 84
 - control with mouse 59
 - pivot
 - light, displaying 77
 - pivot points 103
 - change 113
 - displaying 76
 - planes
 - hiding 75
 - view 35
 - playback
 - frame rate, setting 323
 - range, setting 322
 - Playback Speed option 323
 - Playback Start/End options 322
 - plug-ins
 - load or unload 286
 - manager 331
 - translators 215
 - points
 - about 16
 - measure distance between 230
 - option 87
 - snapping to 35
 - Pole Axis
 - construction plane 145
 - Poly
 - text type 144
 - Polycount
 - Heads Up Display 72

Index

polygons
 display options 311
 select region of 51
 selection options 320
Popup Help 305
Popup Menu Selection modifier option 319
position manipulator 107
Positional tolerance option 315
power modification falloff 137
preferences
 files 290
 files, path 289
Preferences window 303
Prefix Hierarchy Names (Modify menu) 179
Preload Reference Editor 255
pre-loading references 256
Preserve Position 249, 250
 parenting 179
 unparenting 179
Preserve Reference 238, 242
preset attributes 164
previous views
 return 60
primitives
 creating 122
priority selection preference 320
Project (File menu) 247
Project Data Locations 247
projects
 directory, default 316
 organize files 223
propMod script 137, 139
proportional transformation 111
proxy, Web browser 324

Q

quality, performance 287
Queue option 324
Queue Size option 324

quick
 layout buttons 69
 rename 36
 selection 36
Quick Select Set (Create > Sets) 55
Quick Select Sets (Edit menu) 53

R

Radio Button option 327
radio buttons in marking menus 327
Range Slider
 options 322
rebuilding graph 209
recover data after a crash 224
redo 121
Reference Editor 253
Reference Editor (File menu) 247
references
 loading 256
 pre-loading 256
region
 selection, change size of 51
region of effect display 307
Relationship Editor
 interface 259
relative numeric input 36
Reload 39
Reload (Maya browser) 39
Remove Duplicate Shading Networks 238
Remove Instance
 unparenting 179
rename, quick 36
Renderable attribute 99
rendering
 buttons 36
 nodes 157
 resolution 79
repeat last command 121
Repeat on Hold sound option 321
Repeat Size sound option 321
reset tools or actions 25, 26
Reset Transformations (Modify menu) 139

Basics

346

- resize images, Web browser 324
 - Resolution Gate option 79
 - return to previous views 60
 - revolving cameras 80
 - RGB color model 263
 - right mouse button menu 21
 - rigid bodies
 - dynamic options 315
 - Roll Scale setting 83
 - rolling cameras 83
 - rotate
 - axis 130
 - in increments 130
 - modes 129
 - objects 110
 - order 130
 - pivots, displaying 76
 - tool 129
 - Rotate attributes 269
 - Rotate Axis attribute 269
 - Rotate Order attribute 269
 - Rotation 108
 - rotation manipulator 108
 - Rotation type setting 84, 85
 - Run Up From dynamics option 315
 - Run Up To Current Time dynamics option 315
- S**
- Safe Action option 79
 - Safe Title option 80
 - Save Scene (File menu) 234
 - Save Scene As (File menu) 235
 - Saved Layouts 92
 - Saved Layouts (Window menu) 302
 - scale
 - in increments 131
 - manipulator 108
 - objects 110
 - pivots, displaying 76
 - setting 82
 - tool 130
 - Scale attributes 269
 - Scale setting (Azimuth Elevation) 84
 - Scale setting (Yaw Pitch) 84
 - scene
 - file 219
 - hierarchy 152
 - layout for new 305
 - size, optimize 222
 - Scenes 247
 - script nodes
 - about 158
 - execute 233
 - scripts
 - add to shelf 277
 - modification falloff 137
 - on marking menus 327
 - propMod 137, 139
 - storing in scene files 158
 - Select All (Edit menu) 52
 - Select All button 54
 - Select All by Type (Edit menu) 53
 - Select Hierarchy (Edit menu) 52, 178
 - Select paint operation 53
 - Select tool 37
 - selecting 45
 - CVs 53
 - edges 53
 - faces 53
 - priority of 320
 - quick 36
 - vertices 53
 - selection
 - about 17
 - handles, displaying 77
 - options 35
 - selection masks
 - about 34
 - actions 48
 - Selective Preload 233, 255
 - sets
 - defined 213
 - editing 259
 - partitions 228
 - Sets (Create menu) 253
 - settings files, modify 289

Index

- Settings/Preferences (Window menu) 298
- Shade options 87
- Shaded Divisions option 311
- shaded objects
 - smoothness, controlling 311
 - wireframe on 307
- shader libraries
 - browsing with Visor 265
- shading
 - applying to all objects 89
 - interactive 88
- shading groups
 - display example 205
 - displaying in dependency graph 205
- Shading menu 86
- Shadows
 - and hardware shadow maps 90
- shape nodes 157
- Shapes 132
- shapes option 244
- shelf editor 276
- shelves
 - about 22
 - add an item 277
 - custom names or icons 279
 - customize 276
 - default 28
 - edit 278
 - options 300
 - path 289
- shortcuts
 - tools and actions 296
 - tumble, track, dolly 57
 - view 295
- Show (Display menu) 73
- Show Manipulator tool 38
- Show menu
 - Grid 86
 - Isolate Select 85
- Show Nodes Which Are
 - Visor 266
- Show Selected Columns 146
- Show Selected Objects 146
- Shutter Angle attribute 101
- shutters on spotlight 77
- Sidebar buttons 36
- size
 - construction plane 145
 - handles 309
 - manipulators 309
 - of scene, optimize 222
- slanted boxes 208
- Smooth Shade options 87
- smoothness
 - change 63
 - setting 311
- Snap Align Objects (Modify menu) 140
- Snap box dolly to
 - camera settings 82
- snapping
 - all creation tools to a surface or construction plane 117
 - buttons 35
 - move settings 128
 - one object to another 119
 - to a view plane 35
 - to polygonal components 128
 - to View Planes option 35
 - tolerance options 321
- soft edges
 - displaying 312
- sound
 - animation options 321
 - options 234
 - synching 322
- spaces 104
- Special Effects attributes
 - cameras 101
- Specify Selected Lights option 90
- speed of Hypergraph, improving 210
- Spline animation option 317
- status line, about 19
- Step Size
 - rotating 130
 - scaling 131
- Stepped
 - animation option 317
 - Tumble camera setting 81

Stop Loading (Maya browser) 39
 storage tiles 262
 Surface Divisions option 311
 surfaces
 complex operations, controlling 299
 Dolly camera setting 82
 new, display options 311
 show parameter or arc-length values 231
 smoothness, controlling 311
 snapping creation tools 117

T

Tangential tolerance option 315
 tangents, weighted 317
 tear off a window 62
 Tear Off Copy option, Panels menu 93
 Tear Off option, Panels menu 92
 tear-off menus 20
 template objects 225
 Text (Create menu) 144
 text, creating 123
 texture
 displaying in dependency graph 205
 libraries, browsing with Visor 265
 placements, hiding 74
 Threshold
 Output Settings attribute 100
 threshold distances, changing 272
 tilt the view 57
 time ranges, setting 322
 time slider
 height, adjusting 322
 key ticks option 322
 options 322
 time to video standard timecode, default 322
 Timecode animation option 322
 Timecode Offset option 323
 timecodes
 matching timing from videotape 322
 title bar, show 303
 Toggle All button 54

Toggle paint operation 54
 toggling
 CV selection 54
 edge selection 54
 face selection 54
 vertices selection 54
 tolerance
 curves, setting 315
 Tool Box 129
 Tool Settings window 127
 toolbar, about 19
 toolbox 17
 Lasso 37
 Select 37
 Show Manipulator 38
 summary 37
 tools
 about 17
 add to shelf 277
 using 25
 top of a view
 show information 63
 Track Geometry setting 81
 Track Scale setting 81
 track the view 57
 track tool 81
 transform node 157
 transformation
 about 103
 along axes 114
 rotate attributes 130
 set values to zero 115
 type exact values 111
 Transformation Tools (Modify menu) 135
 transition speed, changing 209
 Translate attributes 268
 translators 215
 Transparency Based depth
 Output Settings attributes, for cameras 100
 triad option 128
 Trim
 text type 144

Index

- Tumble
 - about 57
 - camera settings 80
 - Locked camera setting 81
 - Ortho step camera setting 81
 - Orthographic views camera settings 81
 - pivot camera setting 80
 - Stepped camera setting 81
 - Tumble camera about camera settings 80
 - Tumble pivot camera setting 80
 - Tumble scale camera setting 80
 - Tumble Pivot attribute 102
 - Twice (48 fps) playback option 323
 - Two Sided Lighting option 90
- ## U
- UI Elements (Display menu) 41
 - underworld nodes 157
 - undo
 - change history 121
 - option 324
 - setting number of 324
 - Ungroup (Edit menu) 249
 - Ungroup Under 250
 - Unload References 237
 - Unparent (Edit menu) 179
 - Unselect All button 54
 - Unselect brush option 53
 - unselecting
 - CVs 53
 - vertices 53
 - update options, Hypergraph 210
 - Update View animation option 323
 - upstream and downstream connections 210
 - Use All Lights option 89
 - Use Default Lighting option 89
 - Use Namespaces 246
 - Use Previously Specified Lights option 90
 - Use Selected Lights option 89
 - User defined anim curve option 138
 - User defined script option 137, 138
 - user interface
 - about 15
 - customize 273
 - hide elements 304
 - object-specific, show or hide 66
 - preferences files 290
 - userColors.mel 290
 - userHotkeys.mel 290
 - userNamedCommands.mel 290
 - userPrefs.mel 290
 - userRGBColors.mel 290
 - utility nodes 157
 - Update 128
 - UVs
 - linking 259
- ## V
- Vertex
 - snap to 129
 - vertical layout of graph 206, 207
 - Vertical option 80
 - vertices
 - display options 311
 - selecting 53
 - view
 - center 59
 - changing transition speed 209
 - hierarchy and dependency 152
 - planes, snapping to 35
 - return to previous 60
 - View Arrangement (Window menu) 302
 - View menu
 - Camera Settings 78
 - Camera Tools 80
 - Visor window 265
- ## W
- Waveform Display sound option 321
 - waveform, displaying 321

Web browser	22	World	
accessing	31	group under, instances	134
controls	39	world space	104
font size	324	Move tool	127
MEL commands	39	X	
Network and User settings	324	X-ray shade option	87
network configuration	324	Y	
proxy	324	yaw	
resize images	324	control with mouse	59
Weighted Tangents key option	317	of camera	84
white boxes in dependency graph	207, 208	Y-up	
window		about	16
tear off from panel	62	switch to Z-up	287
Window menu		Z	
Frame All in All Views	78	zoom	
Frame Selection in All Views	78	about	57
Saved Layouts	302	cameras	83
Settings/Preferences	298	scale setting	83
View Arrangement	302	Z-up	
windowPrefs.mel	290	about	16
wireframe		switch to Y-up	287
color, change	68		
display	313		
displaying	87		
displaying on shaded objects	307		
option	86		
shade option	87		
Wireframe Color (Display menu)	75		

Index

Basics
352