

Hormone-Dependent Interaction between the Amino- and Carboxyl-Terminal Domains of Progesterone Receptor *in Vitro* and *in Vivo*

Marc J. Tetel*†, Paloma H. Giangrande†, Susan A. Leonhardt, Donald P. McDonnell, and Dean P. Edwards

Department of Pathology and Molecular Biology Program (M.J.T., S.A.L., D.P.E.)
University of Colorado Health Sciences Center
Denver, Colorado 80262

Department of Pharmacology and Cancer Biology (P.H.G., D.P.M.)
Duke University Medical Center
Durham, North Carolina 27710

Full transcriptional activation by steroid hormone receptors requires functional synergy between two transcriptional activation domains (AF) located in the amino (AF-1) and carboxyl (AF-2) terminal regions. One possible mechanism for achieving this functional synergy is a physical intramolecular association between amino (N-) and carboxyl (C-) domains of the receptor. Human progesterone receptor (PR) is expressed in two forms that have distinct functional activities: full-length PR-B and the amino-terminally truncated PR-A. PR-B is generally a stronger activator than PR-A, whereas under certain conditions PR-A can act as a repressor in *trans* of other steroid receptors. We have analyzed whether separately expressed N- (PR-A and PR-B) and C-domains [hinge plus ligand-binding domain (hLBD)] of PR can functionally interact within cells by mammalian two-hybrid assay and whether this involves direct protein contact as determined *in vitro* with purified expressed domains of PR. A hormone agonist-dependent interaction between N-domains and the hLBD was observed functionally by mammalian two-hybrid assay and by direct protein-protein interaction assay *in vitro*. With both experimental approaches, N-C domain interactions were not induced by the progestin antagonist RU486. However, in the presence of the progestin agonist R5020, the N-domain of PR-B interacted more efficiently with the hLBD than the N-domain of PR-A. Coexpression of steroid receptor coactivator-1 (SRC-1) and the CREB binding protein (CBP), enhanced functional interaction between N- and C-domains by mammalian two-hybrid assay. However, addition of SRC-1 and CBP *in*

vitro had no influence on direct interaction between purified N- and C-domains. These results suggest that the interaction between N- and C-domains of PR is direct and requires a hormone agonist-induced conformational change in the LBD that is not allowed by antagonists. Additionally, coactivators are not required for physical association between the N- and C-domains but are capable of enhancing a functionally productive interaction. In addition, the more efficient interaction of the hLBD with the N-domain of PR-B, compared with that of PR-A, suggests that distinct interactions between N- and C-terminal regions contribute to functional differences between PR-A and PR-B. (Molecular Endocrinology 13:910-924, 1999)

INTRODUCTION

The human progesterone receptor (PR) is a member of the nuclear receptor superfamily of transcriptional activators that regulates development, differentiation, and homeostasis of various reproductive functions (1, 2). PR is expressed as two distinct molecular forms from a single gene: full-length PR-B and truncated PR-A that lacks the first 164 amino acids of the amino terminus (3). PR, as well as other steroid receptors, has a conserved structural and functional organization that has been well characterized (1, 2). Both forms of PR are identical in their centrally located DNA-binding domain (DBD) and carboxyl (C-) terminal ligand-binding domain (LBD). PR-A and PR-B also contain two independent transcriptional activation domains (AF): a constitutive AF-1 in the amino terminus and a hormone-dependent AF-2 in the LBD (4, 5). A third transcriptional modulatory domain has been defined in the amino (N-) terminal segment unique to PR-B that re-

quires interaction with other regions of the receptor (5, 6). Under certain cell and promoter contexts, PR-B is a stronger transcriptional activator than PR-A (7–10). This difference in activity is most likely due to conformational or other structural differences between the N termini of the two-receptor isoforms (3, 11, 12). Under conditions in which PR-A is not an activator, it can functionally repress the transcriptional activity of other steroid receptors (7–10). While the mechanism for this repression by PR-A is not fully understood, a discrete transcriptional inhibitory region has been identified in human PR-A that may allow it to interact with factors that do not interact with PR-B (11, 12).

Steroid receptors, including PR, are latent transcription factors that are inactive in the absence of hormone and undergo a multistep activation process upon binding ligand. Receptor activation includes the steps of ligand-induced conformational change, dissociation from an inactive oligomeric complex composed of heat shock proteins and immunophilins, dimerization, and binding to specific DNA sequences of steroid-responsive genes to thereby alter rates of gene transcription (2, 13–15). The identification of coactivators that interact directly with a broad range of nuclear receptors in a hormone- and AF-2-dependent manner has provided important insights into the mechanism by which receptor-DNA interaction modulates gene transcription. The p160 family of coactivators and the CREB binding protein (CBP) family of coactivators (16–20) have been shown to enhance the transcriptional activity of nuclear receptors and to be essential for maximal hormonal responses *in vivo* (16, 21–23). Nuclear receptor coactivators appear to act as bridging proteins between the receptor and general transcription factors, thereby facilitating recruitment of the preinitiation complex. Coactivators are also believed to be involved in targeted remodeling of chromatin due to their intrinsic histone acetyltransferase activity (24–27). The coactivators identified so far primarily interact with and mediate the function of AF-2; AF-1-specific coactivators have not been identified. However, the p160 coactivators such as steroid receptor coactivator SRC-1 and glucocorticoid receptor-interacting protein GRIP-1 have been recently shown to directly interact with amino-terminal sequences of PR or ER, albeit less efficiently than they interact with AF-2, and to be capable of mediating coactivation function through the amino terminus (28–31).

Under certain cell and promoter contexts, both AF-1 and AF-2 can function independently. However, under most conditions, functional synergy between AF-1 and AF-2 is required for full transcriptional activity (4, 5, 32–39). Studies with estrogen receptor (ER) and androgen receptor (AR) have suggested that an intramolecular association between the amino- and carboxyl-terminal regions of receptor contributes to the functional synergy between AF-1 and AF-2. In a modified mammalian cell two-hybrid interaction assay, separately expressed amino- and carboxyl-terminal

domains of ER were observed to functionally interact *in vivo* in a hormone agonist-dependent manner (40). Using both yeast and mammalian two-hybrid interaction assays, several groups have also observed a hormone-agonist dependent interaction between amino- and carboxyl-terminal domains of AR (30, 41–43). It is not clear from these two-hybrid interaction experiments whether amino-carboxyl domain interactions are direct or indirectly mediated by coactivators or other proteins that associate with either domain of the receptor. Functional interactions in a two-hybrid assay could be the result of either direct or indirect binding. Conflicting results have been reported for the effect of nuclear coactivators on functional interactions between N- and C-domains as detected by two-hybrid assays. It was reported that SRC-1 enhances ER N-C domain interactions (44), both SRC-1 and CBP enhanced interactions between the N- and C-domains of AR, while a truncated form of SRC-1 was observed to inhibit these interactions in AR (30). In another study, the transcriptional intermediary factor TIF-2 had no effect on the functional interaction between the N- and C-domains of AR (43). Direct *in vitro* interaction between purified N- and C-domains of steroid receptors has not been reported.

In the present study we have investigated whether the N- and C-domains of human PR are capable of interacting in a hormone agonist-dependent manner. To resolve the question of whether these interdomain interactions are direct or indirect, they were analyzed by direct protein-protein interaction assays *in vitro* with purified N- and C-domain polypeptides of PR and by a mammalian two-hybrid assay. We also investigated whether the N-domains of the A and B forms of PR interact the same or differently with the C-terminal LBD as a possible contributing factor to the different functional activities of the two receptor forms.

RESULTS

Hormone-Agonist Dependent Interaction *in Vitro* between Amino- and Carboxyl-Terminal Domain Polypeptides of PR

Protein-protein interaction *in vitro* between separately expressed N- and C-domains of PR was analyzed initially by a polyhistidine-tagged protein pull-down assay with the polypeptides shown schematically in Fig. 1. The PR fragments included polyhistidine-tagged N-domains of PR-A (ANhis; aa 165–535) and PR-B (BNhis; aa 1–535) and nontagged C-domains containing either the entire LBD (aa 688–933) or the LBD plus hinge region (hLBD; aa 634–933). It should be noted that the expressed N- and C-domains both lack the DBD and thus share no overlapping sequences (Fig. 1) that might contribute to protein-protein interaction through homodimerization. Because the baculovirus PR domain vectors contain polyhistidine tags, it was necessary to cleave the tag from one

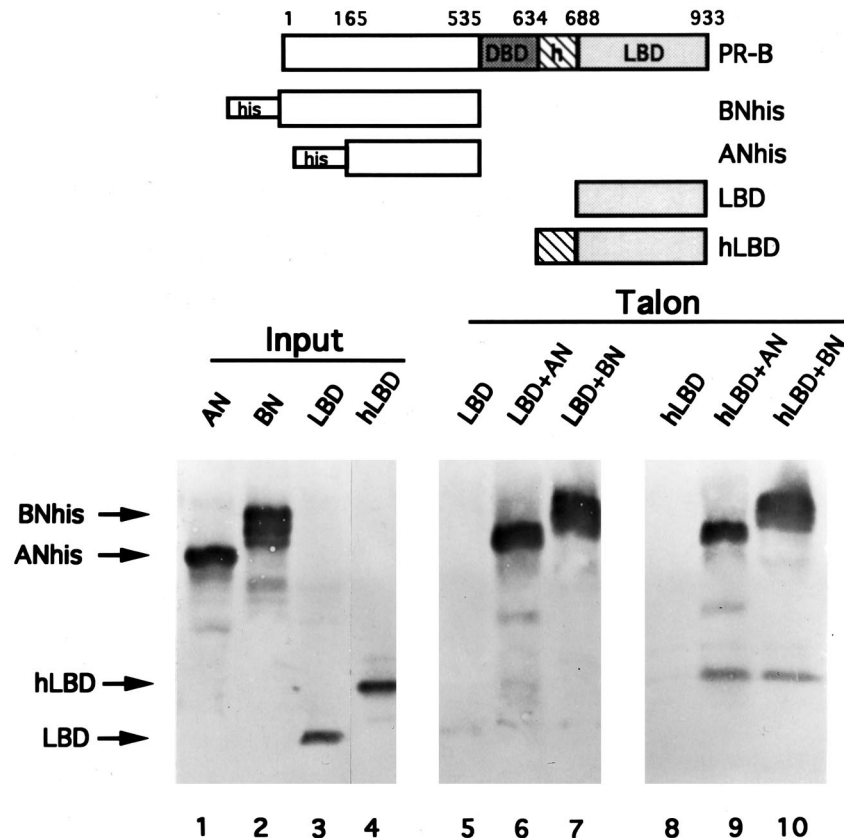

Fig. 1. PR Amino-Carboxyl Terminal Interactions Detected *in Vitro* by Polyhistidine Pull-Down Assay

Schematic of PR domains expressed in baculovirus (*upper panel*): The amino termini of PR-B (BNhis, aa 1–535) and PR-A (ANhis, aa 165–535) were expressed with a 6× polyhistidine tag. The hinge region (h) and ligand binding domain (hLBD, aa 634–933) and the LBD alone (aa 688–933) were expressed and prepared as nonfusion proteins. Full-length PR-B (aa 1–933) is shown for alignment of all the receptor domains. Six sequential N-terminal histidine residues (his). Whole-cell extracts of infected Sf9 cells containing polyhistidine-tagged N-domains of PR-B (BNhis) or PR-A (ANhis) were mixed with equal amounts (determined by Western blot and steroid-binding analysis) of C-terminal domains (LBD or hLBD) and incubated with metal ion affinity resins (Talon). The LBD and hLBD were bound to the synthetic progestin R5020 during expression in Sf9 cells. After washes of the resin, bound proteins were eluted with 2% SDS and analyzed by Western blot with a mixture of MAbs that recognize epitopes in either the N-domain or the LBD of PR (AB-52 and C-262, respectively). Assay input (10%) of polyhistidine-tagged N-domains (ANhis and BNhis), and the carboxyl-terminal, LBD and hLBD, are shown in lanes 1–4. Lanes 5–7 are the LBD incubated with metal resins (Talon) in the absence (nonspecific binding control, lane 5) or presence of ANhis (lane 6) or BNhis (lane 7). Lanes 8–10 are the hLBD incubated with metal resins in the absence (lane 8) or presence of ANhis (lane 9) or BNhis (lane 10). The Western blot detection method was ³⁵S-labeled protein A and autoradiography.

of the paired PR fragments, which was done with the C-domain polypeptides by treatment with enterokinase as described previously (45). Each domain polypeptide was expressed from baculovirus vectors in Sf9 insect cells, and the C-domains were bound to the synthetic progestin R5020 during expression before cell lysis. Whole-cell extracts containing N- or C-domains were mixed and incubated for 30 min at 4 C before immobilization to metal affinity resins (Talon) through the polyhistidine-tagged N-domain polypeptide. After washing the Talon resins with 15 mM imidazole and 100 mM NaCl to remove nonspecific proteins, bound proteins were eluted and analyzed by Western blot with a mixture of monoclonal antibodies (MAbs) that recognize epitopes in the N terminus (AB-52) and the C terminus of PR (C262) (46, 47). To determine the

nonspecific binding of C-domain polypeptides that lack polyhistidine tags, the LBD and hLBD were incubated with Talon resins in the absence of the polyhistidine tagged N-domains of PR (Fig. 1, lanes 5 and 8).

By this pulldown assay, no specific association was detected between the LBD and the N-domains of either form of PR (Fig. 1, lanes 5–7). However, a significant amount of hLBD associated in a specific manner with the N-domain of either PR-A or PR-B (Fig. 1, lanes 8–10). It should be noted that the triplet bands of the N-domain of PR-B are due to phosphorylation sites in the unique N terminus of PR-B (48). The ratio of the C-domain polypeptide specifically associated with Talon-immobilized polyhistidine-tagged N-domains was determined by Phosphorimager analysis from multiple pull-down experiments, and the results are

summarized in Table 1. These quantitative analyses confirmed there was no detectable specific interaction between the LBD and the N-domains of PR-A (LBD/ANhis ratio = 0.02 ± 0.01 , $n = 3$) or PR-B (LBD/BNhis ratio = 0.01 ± 0.01 , $n = 3$). In contrast, a substantial amount of the hLBD specifically associated with the N-domains of either PR-A or PR-B. We also observed a significantly higher ratio of hLBD interaction with the N-domain of PR-B (ratio of hLBD/BNhis = 0.27 ± 0.04) than with the N-domain of PR-A (ratio of hLBD/ANhis = 0.14 ± 0.03 ; $P < 0.05$), (Table 1, R5020 column). Taken together, these results suggest a direct protein interaction between N- and C-domains of PR that requires both the hinge plus LBD as the minimal C-terminal region and that there is a more efficient interaction of the hLBD with the N terminus of PR-B than with the N-domain of PR-A.

To determine whether interaction between N-domains and the hLBD is dependent on ligand binding, similar polyhistidine-tagged protein pull-down experiments were performed with the hLBD prepared in the unliganded state, or bound to R5020 or the progesterone antagonist RU486. The hLBD did not physically associate with the N-domains of PR-A or PR-B in the absence of ligand (Fig. 2, lanes 4–6) or when bound to RU486 (Fig. 2, lanes 7–9). The hLBD efficiently interacted with the N-domains of PR (A or B form) only when bound to R5020 (Fig. 2, lanes 10–12). Results of quantitative analysis by Phosphorimaging of multiple pull-down experiments are summarized in Table 1 and confirm that interaction between the N- and C-domains of PR *in vitro* is dependent on hormone agonist binding to the hLBD and is not allowed by the antagonist RU486.

Interaction between Amino and Carboxyl Domains of PR Is Direct between Purified PR Fragments and Does Not Require Other Proteins

The *in vitro* protein interaction experiments depicted in Figs. 1 and 2 and summarized in Table 1 were performed with PR domain polypeptides present in crude extracts of Sf9 insect cells. To determine whether these interactions are direct or require other proteins, similar pull-down experiments were done using purified PR domain polypeptides. Baculovirus expressed

N-domains of PR (ANhis and BNhis) were purified as described in *Materials and Methods* by affinity chromatography on nickel chelation resins using imidazole to elute the proteins under non-denaturing conditions. Because we encountered problems with low yields of purified polyhistidine-tagged hLBD from nickel resin, followed by enterokinase cleavage necessary to generate nontagged hLBD for polyhistidine pull-down assays, we used a baculovirus-expressed glutathione S-transferase (GST)-tagged hLBD and GST-pull down assays for experiments with purified PR fragments. The hLBD-GST was bound to R5020 during expression in Sf9 insect cells and was purified by affinity chromatography with glutathione-Sepharose resins as described in *Materials and Methods* using reduced glutathione to elute the hLBD under non-denaturing conditions. Silver-stained SDS-gels and Western blot to confirm the identity of the PR domain polypeptides shows that the N-domains of PR-A (AN) and PR-B (BN) and the GST-hLBD were purified to greater than 90% (Fig. 3).

Approximately equal amounts (determined from silver-stained SDS gels) of purified N-domains and hLBD-GST were mixed together in GST pull-down assays. The hLBD-GST and a baculovirus-expressed GST as a control for nonspecific binding were preimmobilized to glutathione-Sepharose resins. The hLBD-GST, GST, and blank resins were then incubated with purified N-domain polypeptides, and after washing of the resins in buffer with 125 mM NaCl, bound proteins were eluted and analyzed by Western blot. Detection of specifically associated N-domains was by use of a MAAb (1294) that recognizes an epitope in the N-terminal region of human PR that is common to both A and B isoforms (Fig. 4). To confirm equal loading and binding of hLBD-GST to the glutathione-Sepharose resins, separate Western blots were performed with the C-262 MAb that recognizes an epitope in the LBD (not shown). A significant fraction of the N-domain of PR-A (AN) (Fig. 4A) and the N-domain of PR-B (BN) (Fig. 4B) specifically associated with hLBD-GST above the little to no binding of the N-domains to GST, or to blank glutathione-Sepharose resins. Quantitative Phosphorimager analysis from multiple

Table 1. Effect of Ligands on PR Amino-Carboxyl Terminal Domain Interactions *in Vitro*

Interacting Domains	Ratio of hLBD to Amino-Terminal Domain (Mean \pm SEM)		
	R5020	No Ligand	RU486
hLBD/ANhis	0.14 ± 0.03 ($n=10$) ^a	0.0 ($n=3$)	0.01 ± 0.01 ($n=3$)
hLBD/BNhis	0.27 ± 0.04 ($n=7$) ^a	0.0 ($n=3$)	0.02 ± 0.02 ($n=3$)

Multiple polyhistidine-tagged protein pull-down assays were quantified by determining the ratio of hLBD to polyhistidine tagged N-domains of PR specifically bound to metal ion affinity resins (Talon). Values (mean \pm SEM) were measured by direct PhosphorImager scanning of Western blots for radioactivity (bound [³⁵S]Protein A) in the receptor bands. The hLBD was bound to 200 nM R5020, 200 nM RU486, or no ligand for the final 6 h of infection of Sf9 cells before cell lysis. Receptor was also exposed to the appropriate ligand *in vitro* during the polyhistidine-tagged protein pull-down assay.

^a $P < 0.05$.

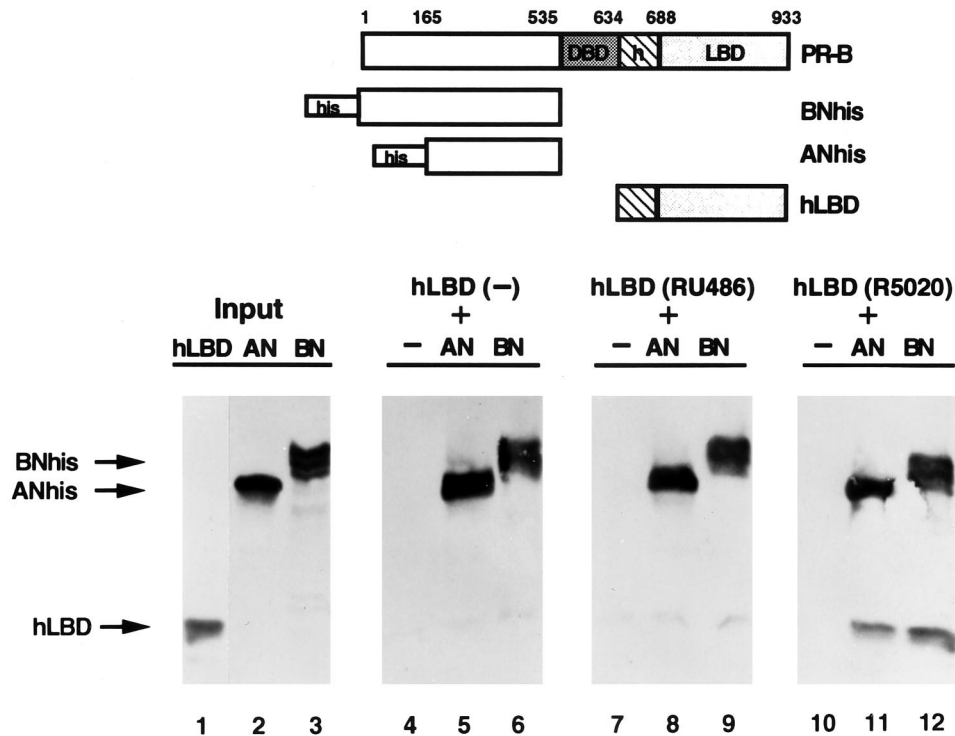

Fig. 2. Interactions of Amino-Carboxyl Domains *in Vitro* are Hormone Agonist Dependent

Whole-cell extracts of Sf9 cells containing the PR domains shown in the schematic were mixed, and association between the N-domains and the hLBD was detected by polyhistidine-tagged pull-down assay as described in Fig. 1. The hLBD was either unliganded (lanes 4–6) or was bound to RU486 (lanes 7–8) or R5020 (lanes 10–12). Proteins bound to Talon resins were eluted and analyzed by Western blot with a mixture of MAbs (AB-52 and C-262) that together detect the N-domains and the hLBD. Inputs (10% of total) of the hLBD and the polyhistidine-tagged N-domain (ANhis and BNhis) are shown in lanes 1–3.

GST pull-down assays similar to that in Fig. 4 revealed that, on average, 5.7% (SEM ± 1.12%, n = 9) of the assay input of the N-domain of PR-B and 6.51% (SEM ± 0.801, n = 9) of the input of the N-domain of PR-A specifically associated with immobilized hLBD-GST. Thus, the more efficient interaction of the hLBD with the N-domain of PR-B, as compared with the N-domain of PR-A that was detected with PR domain polypeptides prepared as crude cell extracts, was not detected by GST pull-down assay with highly purified PR fragments. Whether these different results are due to the use of different assay methods (GST vs. polyhistidine pull-down assays) or to the presence of other bridging proteins that facilitate interaction between the N-domain of PR-B and the hLBD is not known. To investigate this question further we analyzed the influence of SRC-1 and CBP on the interaction between purified N- and C-domain PR fragments. SRC-1 and CBP were each expressed as full-length proteins with polyhistidine tags in the baculovirus system and were purified by nickel chelation affinity chromatography. As a control for the general effect of other proteins on the stability of highly purified PR fragments, ovalbumin (10 μg) was added and was observed to have no effect on these *in vitro* interactions (not shown). Addition of SRC-1, CBP, or

both proteins together also had no influence on the interactions detected by GST pull-down assay between purified N-domains of PR-A or PR-B with the hLBD (not shown). Thus, we conclude that the N-domains of PR-A and PR-B can make direct protein contact with the hLBD in a manner that does not require SRC-1 or CBP. These results with purified PR fragments also suggest that the more efficient interaction of the hLBD with the N-domain of PR-B, as compared with the N-domain of PR-A observed in whole-cell extracts, is likely due to proteins other than SRC-1/CBP, or to a coactivator complex consisting of SRC-1 and CBP plus additional factors.

Functional Hormone-Agonist Dependent Interaction between the Amino- and Carboxyl-Terminal Domains of PR by Mammalian Two-Hybrid Assay

A mammalian two-hybrid assay was used to determine whether the N-terminal regions of PR-A and PR-B can functionally interact with the C-terminal hLBD within cells. The hybrid protein constructs depicted in Fig. 5 included the hLBD fused to the DBD of Gal4 (hLBD-Gal4) and the N-domains of PR-A (AN-VP16) and PR-B (BN-VP16) fused to the VP16 transcriptional activation domain. An SV40

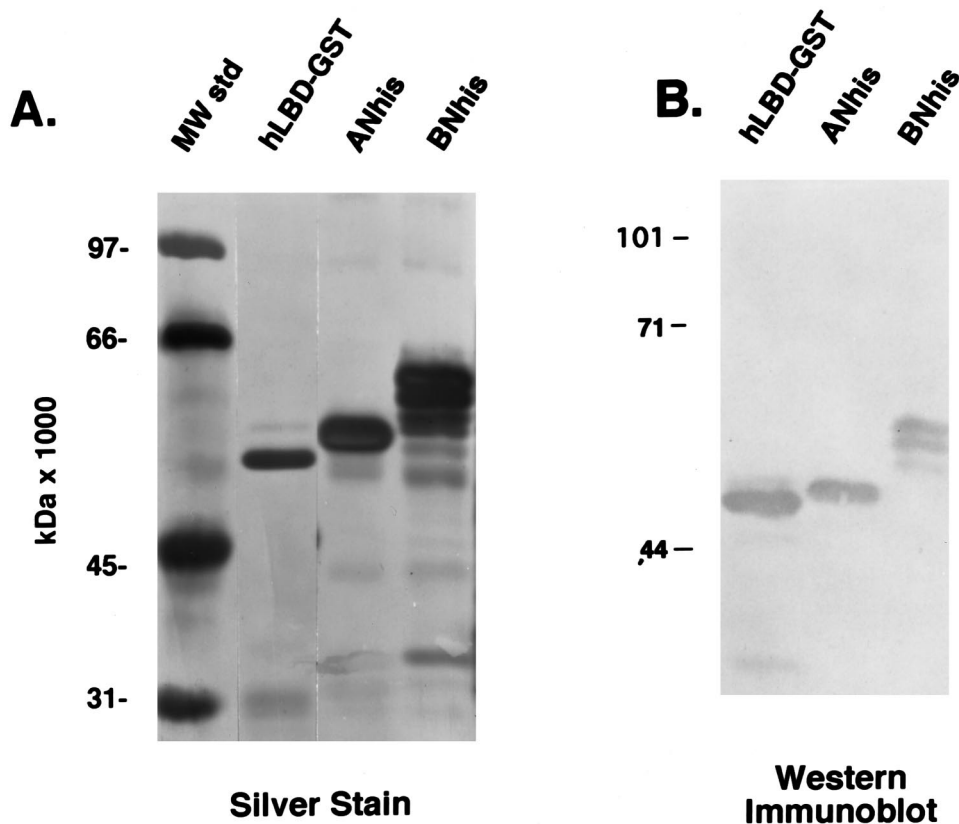

Fig. 3. Purification of PR Domain Polypeptides

Recombinant PR hLBD-GST purified by glutathione Sepharose 4B affinity chromatography, and the N-domains of PR-A (ANhis) and PR-B (BNhis) purified by Ni-NTA affinity chromatography, were analyzed by SDS-PAGE and silver staining (panel A) and by Western blot (panel B) with a mixture of MAbs that recognize epitopes in the N-domain common to PR-A and PR-B (AB-52) and in the LBD (C262).

large T antigen fused to VP16 (T-VP16) was used as a control for nonspecific interaction of the hLBD with an unrelated protein. A luciferase gene inserted downstream of five Gal4 DNA-binding sites ($5 \times$ Gal4-RE-LUC) was used as the reporter for detection of functional interaction between hLBD-Gal4 and the VP16 fusion proteins (Fig. 5). Human hepatoma (HepG2) or human cervical carcinoma (HeLa) cells were cotransfected with hLBD-Gal4 and one of the three VP16-fusion constructs, and the cells were treated without and with PR ligands for 48 h before harvest and measurement of luciferase activity. Western blot analysis confirmed that the fusion products were expressed as correctly sized proteins and at levels similar to full-length transfected wild-type PR (data not shown). For the experiments in Fig. 6, the nonspecific luciferase expression resulting from interaction between SV40-VP16 and hLBD-Gal4 for each ligand treatment group was normalized to a value of 1.0, and the specific luciferase expression, dependent on both hLBD-Gal4 and PR N-domain VP16 fusion constructs, was calculated as the fold induction over the nonspecific expression of luciferase.

In the absence of ligand, hLBD-Gal4 did not functionally interact in either HepG2 cells (Fig. 6A) or HeLa cells (Fig. 6B) with the N-domain-VP16 fusions of either PR-A (AN-VP16) or PR-B (BN-VP16) above that of the background interaction with SV40-VP16 (T-VP16). However, progesterone addition to both cell types induced a significant functional interaction between hLBD-Gal4 and either PR N-domain VP16 construct (Fig. 6). Additionally, hLBD-Gal4 interacted more efficiently with the N terminus of PR-B (5.2 ± 0.1 fold induction in HepG2 and 6.3 ± 0.7 in HeLa cells) than the N-domain of PR-A ($2.7 \pm .01$ in HepG2 and 4.0 ± 0.3 in HeLa cells; $P < 0.05$) in both cell lines (Fig. 6). In agreement with the *in vitro* protein-protein interaction results, RU486 failed to induce a functional interaction between hLBD-Gal4 and either PR isoform N-domain construct in HepG2 cells (Fig. 6A) and with the N-domain of PR-A in HeLa cells (Fig. 6B). However, in HeLa cells a small but significant RU486 stimulation (1.9 ± 0.3 -fold over the T-VP16 control, $P < .01$) of hLBD-Gal4 interaction with the N-domain of PR-B was observed, which was considerably less than that stimulated by progesterone (Fig. 6B). Thus, functional

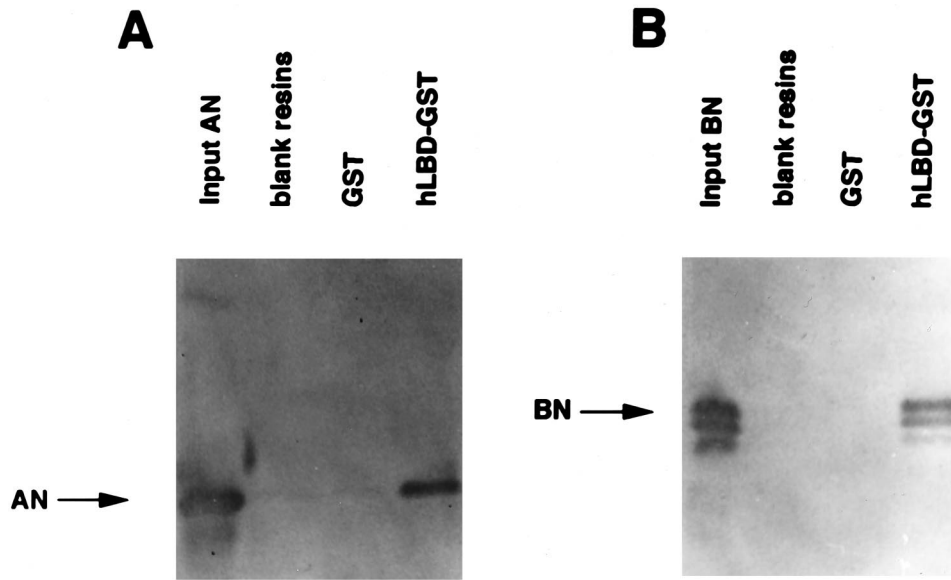

Fig. 4. Direct Interaction *in Vitro* between purified N- and C-Domains of PR
Purified hLBD-GST, or GST as a control, were preimmobilized to glutathione Sepharose. Equal amounts (determined by Western blot) of purified N-domains of PR-A (panel A) or PR-B (panel B) were incubated with the hLBD-GST, GST, or blank resins for 1 h at 4 C. After washing of resins, bound proteins were eluted and analyzed by Western blot with an MAb (1294) that detects an epitope in the N-domain common to PR-A and PR-B. Assay input (10%) of the N terminus of PR-A (AN) or PR-B (BN) for each GST-pull down assay is indicated.

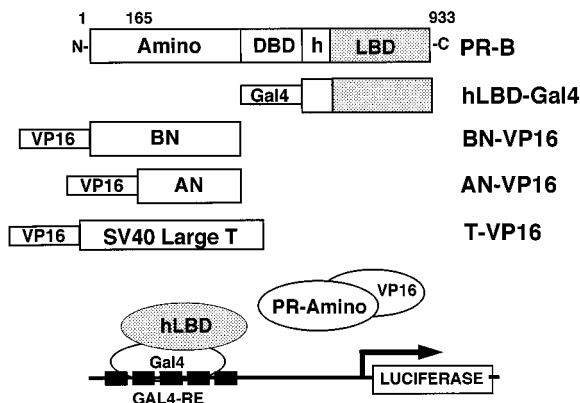

Fig. 5. Mammalian Two-Hybrid Assay Constructs
Schematic diagram of the fusion constructs and reporter gene used in the mammalian two-hybrid assay. The VP16 acidic activation domain (aa 411–455) was fused to the N terminus of PR-B (aa 1–550, BN-VP16), the N terminus of PR-A (aa 165–550, AN-VP16), or the SV40 large T antigen (T-VP16). The Gal4 DBD (aa 1–147) was fused to the PR LBD plus hinge sequences (aa 634–933) to yield hLBD-Gal4. Interaction between the hLBD-Gal4 and N-domain VP16 fusion proteins was measured as an induction of expression of the luciferase reporter gene under the regulation of five Gal4 DNA-binding sites (5× Gal4-RE-LUC).

interaction between the C- and N-domains of PR within mammalian cells is hormone agonist-dependent and is either not allowed or greatly reduced (hLBD interaction with the N-domain of PR-B in HeLa cells) by the antagonist RU486.

Coactivators Are Involved in Functional Interaction between Amino- and Carboxyl-Terminal Domains of PR within Whole Cells

To investigate the role of transcriptional coactivators in the functional interaction between the N- and C-domains of PR, we analyzed whether coexpression of full-length SRC-1, CBP, or both proteins would influence these interdomain interactions in the mammalian two-hybrid assay. Separate cotransfections with either SRC-1 or CBP in HepG2 (Fig. 7) or HeLa cells (data not shown) had minimal effect on progesterone-dependent interaction between hLBD-Gal4 and the N-domain VP16 constructs of PR-A and PR-B. However, cotransfection with SRC-1 and CBP together resulted in a significant stimulation of progesterone-dependent functional interaction between hLBD-Gal4 and the N-domains of PR-A or PR-B (Fig. 7). In HepG2 cells, cotransfected SRC-1 and CBP together increased hLBD-Gal4 interaction with PR-B N-domain from a 4.6- to a 13-fold induction (2.8×) and hLBD-Gal4 interaction with PR-A N-domain from a 3.2 to a 6.6 fold induction (2.06×) (Fig. 7). A similar enhancement of functional interaction between hLBD and the N terminus of PR-B (3.37-fold increase) and the N-terminus of PR-A (4.41-fold increase) was observed by cotransfecting HeLa cells with SRC-1 and CBP (not shown). Enhancement by SRC-1 and CBP is largely PR specific and does not appear to be due to a coactivation effect on general transcription. Coexpression of SRC-1 and CBP together resulted in only a 1.4-

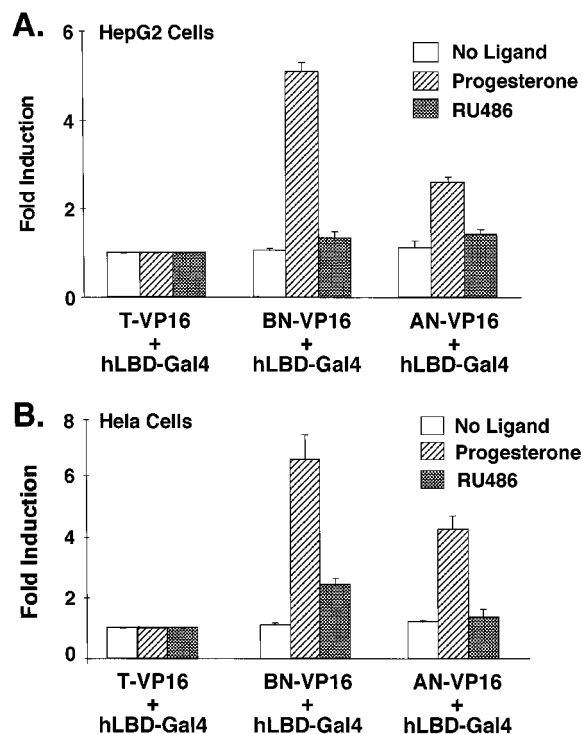

Fig. 6. Hormone Agonist-Dependent Functional Interaction between Amino and Carboxyl Domains of PR

HepG2 cells (A) or HeLa cells (B) were transiently cotransfected with hLBD-Gal4 and VP16 fusion constructs containing the N-domains of PR-B (BN-VP16), PR-A (AN-VP16), or the SV40 large T antigen (T-VP16). Transcriptional activity of the luciferase gene was assayed on the 5× Gal4-RE-LUC reporter as a measure of functional interaction between Gal4 and VP16 fusion proteins. Transcriptional activity was measured in the absence of ligand or in the presence of progesterone (10^{-7} M) or the progesterone antagonist RU486 (10^{-7} M). The data are represented as fold induction over the control interaction between hLBD-Gal4 and T-VP16 for each ligand treatment group that was normalized to 1.0. Bars are the mean \pm SEM from three independent experiments.

to 1.5-fold stimulation of Gal4-VP16 transactivation of the Gal4-RE-LUC reporter gene in both HeLa and HepG2 cells, indicating that SRC-1 and CBP are not affecting transcription activation in general (not shown).

To test the extent to which coactivators are essential for functional interaction between N- and C-domains of PR, the activities of endogenous SRC-1 and CBP were inhibited in the mammalian two-hybrid assay. To inhibit SRC-1, cells were cotransfected with a dominant-negative form of SRC-1 (0.8) that contains the C-terminal nuclear receptor-binding site enabling it to bind to PR, but lacks the centrally located nuclear receptor-binding sites and both transcriptional activation domains (16, 28). Coexpression of SRC-1 (0.8) in the mammalian two-hybrid assay effectively inhibited progesterone-dependent interaction between hLBD-Gal4 and the N-domains of either PR isoform (Fig. 8A). To inactivate endogenous CBP, cells were cotrans-

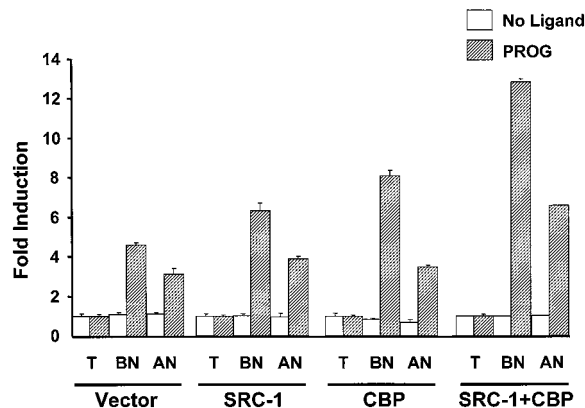

Fig. 7. Coexpression of Coactivators Enhances Functional Interaction between Amino and Carboxyl Domains of PR

HepG2 cells were transiently transfected with hLBD-Gal4 and the VP16 fusion constructs expressing SV40 large T antigen (T), or the N-domains of PR-B (BN) or PR-A (AN), as in Fig. 6, except in the absence (empty pCR3.1 vector) or presence of expression vectors for SRC-1, CBP, or both coactivators. The data are calculated as fold inductions over the control interaction between hLBD-Gal4 and T-VP16 for each group and are the mean of triplicate determinations (\pm SEM) from a single representative experiment.

ected with an expression plasmid for the adenovirus protein 12S E1A (E1A), which binds to the third zinc finger motif of CBP and inactivates its coactivator function (49). E1A cotransfection in the mammalian two-hybrid assay effectively inhibited progesterone induction of the functional interaction between hLBD-Gal4 and the N-domains of either PR isoform (Fig. 8B). As a control for effects on general transcription activation, the dominant negative SRC-1 (0.8) and E1A did not affect the constitutive transactivation of the GAL4-RE-LUC reporter mediated by a Gal4-VP16 activator (not shown). These mammalian two-hybrid results, taken together with the *in vitro* protein-protein interaction data, suggest that SRC-1 and CBP are essential for functional hormone-dependent interaction between the amino- and carboxyl-terminal domains of PR, but are not required as bridging, or adaptor, proteins for association between the N- and C-domains, which occurs by direct contact in the absence of other proteins.

DISCUSSION

Full transcriptional activity of steroid receptors requires functional synergy between activation functions located in the amino and carboxyl domains of receptor (4, 5, 32–39). Previous studies with ER (40) and AR (30, 41–44) using a standard or modified two-hybrid assay, suggest that this functional synergy involves a ligand-dependent association between the amino and carboxyl domains of receptor. Using a mammalian two-hybrid interaction system, we have also observed a

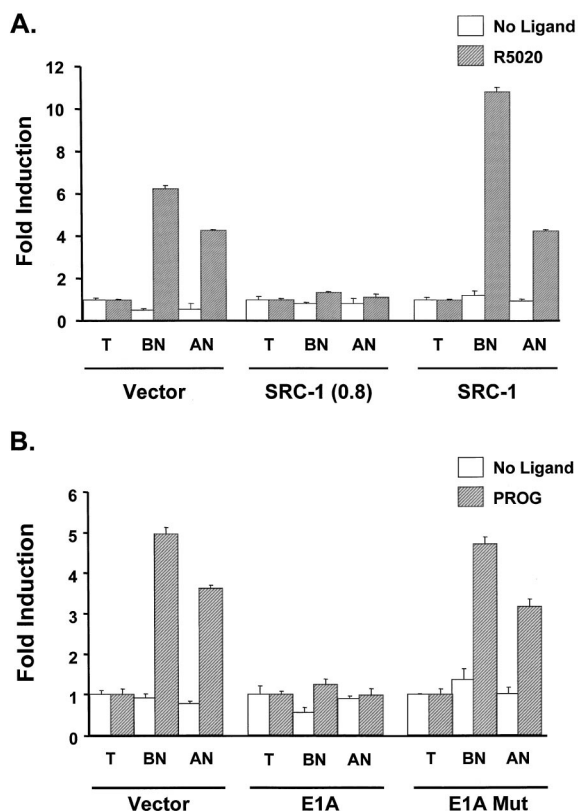

Fig. 8. Inactivation of Endogenous Coactivators Inhibits Functional Two-Hybrid Interaction Between N- and C-Domains of PR

HeLa cells were cotransfected with hLBD-Gal4 and VP16 fusion constructs (T-VP16, AN-VP16, and BN VP16) as in Figs. 6 and 7, except that cells were also transfected with and without (empty vector) a dominant negative SRC-1 (0.8) (panel A) or the adenovirus protein E1A (panel B). Luciferase activity was normalized to β -galactosidase activity and calculated as in Figs. 6 and 7. The data are mean values of triplicate determinations (\pm SEM) from a single representative experiment.

hormone-agonist dependent functional interaction between N-terminal domains and the hLBD of human PR, suggesting that N-C interdomain interaction is a common mechanism for all steroid hormone receptors. An unresolved question from previous two-hybrid results is whether the observed functional interaction represents direct protein contacts or is indirectly mediated by other proteins that associate with either N- or C-domains of the receptor. To resolve this question we have investigated the ability of N- and C-domain polypeptides of PR to interact directly *in vitro*. When expressed as recombinant polypeptides in Sf9 cells and prepared as whole-cell extracts, the N-domains of both PR isoforms interacted efficiently with the C-terminal hLBD of PR. Furthermore, this *in vitro* interaction was dependent on the hormone agonist R5020 and was not detected in the absence of ligand (Figs. 1 and 2). When the N- and C-domain polypeptides were purified to more than 90% from Sf9 whole-cell ex-

tracts, they continued to interact by pull-down assay in a specific manner indicating that the N- and C-domains of PR are capable of making direct protein contacts and do not require other proteins to physically associate.

While the interaction between the amino- and carboxyl domains of PR *in vitro* (Fig. 2 and Table 1), and within cells by mammalian two-hybrid assay, was observed to be hormone agonist dependent (Fig. 6), little or no interaction was detected by either experimental approach in the presence of the progesterone antagonist RU486. Androgen antagonists were similarly reported to diminish functional interaction between the N- and C-domains of AR in a mammalian two-hybrid assay (42). However, different results were observed for the effects of the antiestrogen *trans*-hydroxytamoxifen (TOT), on ER N-C domain interactions. Separately expressed ER polypeptides containing the amino terminus linked to the DBD and the LBD were observed to functionally interact on an estrogen response element (ERE)-controlled reporter gene in response to estradiol, but not to TOT. In contrast, TOT was observed to induce a strong functional interaction between the N-terminal DBD construct and the LBD on the ERE-responsive reporter gene when the LBD was fused to VP16 (40). Because TOT only induced a response between the N- and C-domains when the LBD was expressed as a fusion protein with VP16, it has been suggested that TOT produces a nonproductive interaction between the N- and C-domains (40). A different conclusion must be drawn from the present studies for the influence of RU486 on PR N-C domain interactions, since RU486 failed to induce an interaction between the N-domains and the hLBD of PR *in vitro* (Fig. 2) and functionally inhibited hLBD interaction with N-domain VP16 fusion construct in whole cells by mammalian two-hybrid assay (Fig. 6). Thus, we conclude that RU486 fails to induce, or impairs, a physical association between the N- and C-domains of PR, rather than promoting an interaction that is transcriptionally nonproductive as reported for the effect of TOT on ER N-C domain interaction (40). The reason for the apparent difference between RU486 and TOT is not known. This could be due to differences in assay methods, or to RU486 antagonism of PR operating by a different mechanism than TOT antagonism of ER. Indeed, TOT is well known to exhibit partial agonist effects that are both cell type and promoter dependent, suggesting this difference between TOT and RU486 may reflect the partial agonist effects of TOT. In this regard, RU486 exhibits cell- and promoter-specific partial agonist effects that are mediated solely by the B isoform of PR (4, 7, 10). RU486 stimulated a weak functional interaction between the N terminus of PR-B and the hLBD in HeLa cells that was not observed in HepG2 cells (Fig. 6). This weak RU486 stimulation of N-C interaction correlates with the previously reported weak agonist activity of RU486 mediated by full-length PR-B in HeLa cells on selected promoters (4, 9). Many studies have revealed that ago-

nists and antagonists induce distinct conformational changes in the LBD of steroid receptors and that these conformations are central to whether receptor is transcriptionally active or inactive (50–53). Therefore, an altered conformation in the LBD of PR induced by RU486 may contribute to inactivation of receptor by not permitting an efficient physical association between the amino and carboxyl domains.

The p160 family of nuclear receptor coactivators was initially identified as AF-2-interacting proteins and has been shown to interact with AF-2 as a complex of coactivators consisting minimally of p160 as the direct binding component, CBP, and pCAF (CBP-associated factor) (17–22). The p160 proteins, SRC-1 and GRIP1, have also been found to be capable of interacting with and mediating coactivation effects through N-terminal regions of ER and PR (28–31). Interestingly, separate regions of p160 proteins interact with N- and C-domains of receptors, suggesting that p160 proteins are capable of mediating, or bridging, an association between the N- and C-domains of the receptor (Ref. 31 and V. Boonyaratanakornkit and D. P. Edwards, unpublished). To address the role of coactivators in terms of N-C-domain interactions of PR, the present study analyzed the influence of SRC-1 and CBP on direct N-C domain binding *in vitro* with purified PR fragments and functionally by mammalian two-hybrid assay. Addition of SRC-1, CBP, or both proteins together had no effect on the direct interactions between purified N- and C-domains of PR. However, when cells were cotransfected with SRC-1 and CBP expression plasmids together, functional hormone-dependent interaction between the N- and C-domains of PR in the mammalian two-hybrid assay was enhanced (Fig. 7). Additionally, inactivation of endogenous SRC-1 by transfecting cells with a dominant negative mutant form of SRC-1 (16), or inactivation of CBP with EIA (49), effectively inhibited functional interaction between the N- and C-domains (Fig. 8). The influence of the dominant negative SRC-1 does not preclude other closely related nuclear receptor coactivators from having a role in mediating a functional N-C domain interaction. The dominant negative SRC-1 may compete with other coactivators containing the same nuclear receptor interaction box sequences (LXXLL motif) that bind AF-2 in the LBD. These direct *in vitro* binding and functional two-hybrid results, taken together, are consistent with the conclusion that the N- and C-domains of PR are capable of making direct protein contact without the aid of coactivators, but that transcriptionally productive interactions require both SRC-1 (or closely related coactivators) and CBP.

Although SRC-1, CBP, or both proteins had no influence on interactions between purified N- and C-domain PR fragments, we observed that CBP addition to the PR domain polypeptides in crude extracts of Sf9 cells increased N-C domain interactions (not shown).

Since coactivators appear to exist as preformed multiprotein complexes containing SRC-1, CBP, pCAF, and other factors (17), this result suggests the possibility that CBP, as a component of a larger protein complex, can facilitate or stabilize direct associations between the C and N termini of PR.

When comparing the interaction of the hLBD with the N-domains of the two forms of PR, the N-domain of PR-B was found to interact more efficiently than the N-domain of PR-A. This differential interaction was detected functionally by mammalian two-hybrid assay and *in vitro* by pull-down assays with PR domain polypeptides prepared as whole-cell extracts of Sf9 cells. However, this differential was not observed *in vitro* with highly purified PR domain polypeptides, suggesting that the more efficient interaction of the N-domain of PR-B with the hLBD is dependent on other proteins, most likely coactivator complexes containing SRC-1, CBP, and other components. Additionally, the more efficient interaction observed between the hLBD and the N terminus of PR-B, as compared with the N terminus of PR-A, could be due to 1) additional protein contact sites provided by the extended N-terminal segment unique to PR-B; 2) a different overall conformation conferred by the unique N terminus of PR-B on sites that are common to the N-domains of PR-A and PR-B; or 3) the three phosphorylation sites that are located in the N-terminal segment unique to PR-B (48). Further studies are required to distinguish between these possibilities. The more efficient interaction of the hLBD with the N terminus of PR-B, compared with the N-terminus of PR-A, under the conditions observed in this study, correlates with PR-B functioning as a generally stronger transcriptional activator than PR-A (7–12). These results support the notion that a differential association between the C-terminal hLBD and the N terminus of PR-A and PR-B contributes to the experimentally observed differences in transcriptional activities of the two PR isoforms.

Because the N- and C-domains of PR were expressed as separate polypeptides, the present results cannot distinguish between an intramolecular association between the N and C termini in the full-length receptor and an intermolecular interaction resulting from antiparallel dimerization as suggested by studies with AR (41, 54). Several lines of evidence indicate that PR homodimerization occurs in a parallel fashion, thus supporting the notion that the observed N-C domain interactions reflect an intramolecular association. For example, we and others have shown that the C-terminal hLBD of PR is capable of mediating homodimerization in the absence of N-terminal sequences (45, 55). Furthermore, fusion of the leucine zipper of *c-fos* or *c-jun* to the C terminus of full-length PR forced parallel dimers that were transcriptionally active (56). However, whether *fos/jun*-forced antiparallel dimers are also active was not tested. Additionally, the recently published three-dimensional structure of the

LBD of PR bound to agonist revealed the presence of a dimer interface that mediates parallel interactions through the C terminus (57). As a further suggestion that interactions between isolated N- and C-domains detected in this study *in vitro* and *in vivo* by mammalian two-hybrid assay reflect an intramolecular interaction within the holoreceptor, the N- and C-domains of PR coexpressed in mammalian cells attached to their own DBD were observed to reconstitute a functional transcriptional response *in trans* on a progesterone response element-containing reporter gene (28). Furthermore, cotransfection with SRC-1, or the closely related TIF-2, markedly enhanced this transcriptional response.

The hLBD was capable of interacting with the N-domain of PR *in vitro*, while the LBD was not (Fig. 1), suggesting the hinge region is involved in N-C domain interactions. Whether hinge sequences are directly involved in protein interaction with N-domain fragments has not been investigated. Although a direct involvement remains a possibility, we favor the idea that the hinge exerts an effect on the conformation of the LBD enabling it to make protein contacts with N-domains. Although studies to show directly whether the hinge confers structural stability on the PR LBD have not been performed, indirect functional studies comparing the LBD and hLBD fragments are consistent with this role for the hinge. We have shown previously that the expressed LBD alone is not capable of mediating homodimerization and binds ligand with an affinity that is 3- to 4-fold lower than the affinity of full-length receptor. The LBD with additional hinge sequences is the minimum region of PR capable of binding ligand with wild-type affinity and mediating homodimerization (45).

In Fig. 9 we have modeled our findings in the context of full-length PR. We propose that a fully active receptor requires assembly of AF-1 and AF-2 from different regions of the same PR polypeptide. Receptor bound to agonist undergoes a conformational change that allows a direct intramolecular association between the N- and C-domains (*dashed lines*). The p160 subunit of the transcriptional coactivator complex is capable of simultaneously binding with amino (AF-1) and carboxyl (AF-2) regions of receptor, and this complex is required for a transcriptionally productive interaction between the N- and C-domains. The N terminus of PR-B interacts more efficiently with the hLBD than the N terminus of PR-A, suggesting that differential N-C domain interactions contribute to the distinct functional activities of PR-A and PR-B. This differential interaction appears to be facilitated by protein components (*checkered symbol*) of a coactivator complex through the extended N-terminal segment of PR-B. Direct N-C domain interactions are markedly inhibited in the presence of RU486, suggesting that failure to induce an association between the N- and C-domains contributes to the mechanism by which antagonists inactivate the receptor.

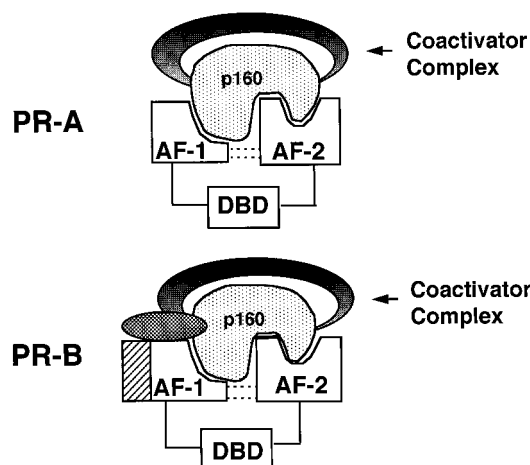

Fig. 9. Model of Hormone Agonist-Dependent Intramolecular Association of Amino and Carboxyl Domains of PR

The three major domains of PR-A and PR-B are indicated schematically: the amino-terminal domain containing AF-1, the DBD, and the carboxyl-terminal LBD containing AF-2. The model depicts the hormone agonist-activated PR with the *stippled* region representing the N-terminal extended segment unique to PR-B. The *dashed lines* represent direct contacts between N- and C-domains, and the coactivator complexes associated with PR-A and PR-B contain distinct subunit compositions.

MATERIALS AND METHODS

Materials

Unlabeled progesterone and ovalbumin were purchased from Sigma Chemical Co. (St. Louis, MO). Unlabeled RU486 (Mifepristone, 17-hydroxy-11 [4-dimethylamino-phenyl] 17-propynyl-estra-4, 5-diene-3-one) was a gift from Roussel-UCLAF (Romainville, France) or Ligand Pharmaceuticals, Inc. (San Diego, CA). Nickel-NTA (Ni-NTA) and metal ion affinity resins (Talon) were obtained from Qiagen (Valencia, CA) and CLONTECH Laboratories, Inc. (Palo Alto, CA), respectively. Mouse IgG1 MAbs generated against human PR include AB-52 and 1294, which recognize epitopes in the amino terminus common to PR-A and PR-B (Ref. 46 and B. Spaulding, L. Sherman, and D. P. Edwards, unpublished data), B-30, which recognizes only PR-B (46), and C-262, which is directed against the last 14 amino acids of the carboxyl-terminal end of PR (47). A polyclonal antibody raised against PR-A (B13-TK) was a gift from Nancy Weigel (Baylor College of Medicine, Houston, TX). A MAb generated against the polyhistidine tag and enterokinase cleavage site fusion sequences (mouse IgG clone 1162/F6) contained in the pBlueBacHis2 baculovirus transfer plasmid (Invitrogen) was used for Western blot detection of baculovirus polyhistidine-tagged proteins and a MAb produced to GST (mouse IgG clone 794/H12) was used for Western blot detection of GST-fusion proteins (D. P. Edwards and S. Anderson, unpublished data). Secondary antibodies, Hybond-C Extra (nitrocellulose) transfer membrane, and x-ray developing film were obtained from Amersham (Arlington Heights, IL). DNA restriction and modification enzymes were obtained from Promega Corp. (Madison, WI), Boehringer Mannheim (Indianapolis, IN), or New England Biolabs, Inc. (Beverly, MA). PCR reagents were obtained from Perkin-Elmer Corp. (Norwalk, CT) or Promega Corp.

Expression of PR Fragments and Coactivators in the Baculovirus Insect Cell System

Recombinant baculovirus vectors expressing different domains of PR with N-terminal polyhistidine tags (6 \times) (Fig. 1) included the N terminus of PR-B (BNhis, aa 1–535), the N-terminus of PR-A (ANhis, aa 165–535), and the hLBD (aa 634–933). The LBD alone (aa 688–933) was expressed without polyhistidine tags. These vectors have been described and used previously (45) except for BNhis, which was constructed by restriction digestion of PR-B from plasmid pPR-B (7, 59) by *Eco*NI, which dropped out the base pair 1779–2671 fragment of PR-B cDNA. The *Eco*NI ends were made blunt by digestion with Mung Bean nuclease and then religated resulting in a cDNA encoding a PR fragment, aa 1–535. For expression of the hLBD as a fusion protein containing an amino-terminal GST tag (hLBD-GST), the hLBD was generated by PCR with the primers 5'-GATCGGATCCG-GCATGGTCCTTG GAGGT and 5'-CTAGAATCCAAAGATGACATTCACTTTTATG, using the pT7BhPR-A plasmid (provided by M. Tsai and B. O'Malley, Baylor College of Medicine, Houston, TX) as the template cDNA (50). The PCR amplification product resulted in aa 634–933 of PR containing *Bam*HI and *Eco*RI restriction sites at the 5'- and 3'-ends, respectively, which was ligated into the respective restriction sites of the pAcG2T baculovirus transfer vector (PharMingen, San Diego, CA).

A recombinant baculovirus transfer vector for steroid receptor coactivator-1 (SRC-1) (16) was constructed by inserting the SRC-1 cDNA excised from pBK-CMV SRC-1 (provided by Sergio Oñate, M.-J. Tsai and B. O'Malley, Baylor College of Medicine) into *Bam*HI and *Pst*I sites of the baculovirus transfer plasmid pBlueBacHis2(C) (Invitrogen). The SRC-1 coding region was inserted in frame with amino-terminal sequences of the plasmid containing an ATG translation start site, six sequential histidine residues, and an enterokinase cleavage site encoding aa 361–1440 of SRC-1 (SRC-1 his). The recombinant virus for expression of full-length mouse CBP as an N-terminally polyhistidine-tagged protein (CBP_{his}) was provided by N. Weigel and B. O'Malley (Baylor College of Medicine).

Spodoptera frugiperda (Sf9) insect cells were grown in spinner vessels (150–500 ml) in Graces' insect cell medium supplemented with 10% FBS (HyClone Laboratories, Inc., Logan, UT). Cells were infected with recombinant viruses at a multiplicity of infection of 1.0 for 48 h at 27 C as described previously (51, 58). Insect cell cultures for expression of C-terminal PR fragments were incubated with 200 nM R5020 or RU486, as indicated, for the final 6 h of infection before harvest.

Purification of Baculovirus-Expressed PR Domains and Coactivators

The N-terminal domains of PR-A and PR-B expressed in baculovirus with a polyhistidine tag (ANhis and BNhis) were purified by metal ion affinity chromatography as described previously (58, 59) with minor modifications. Sf9 cells expressing either ANhis or BNhis were lysed in 20 mM Tris and 10% glycerol (TG) buffer, pH 8.0, containing 350 mM NaCl, 15 mM imidazole, 1 mM β -mercaptoethanol, and a mixture of protease inhibitors (59). All procedures were done at 0–4 C. Cell lysates were centrifuged at 100,000 $\times g$ for 30 min, and the supernatant was taken as a soluble whole-cell extract. Whole-cell extracts were bound to nickel affinity resins (1 ml packed Ni-NTA resins) by resuspension in a 50-ml siliconized tube followed by incubation for 1 h on an end-over-end rotator. The resins were then washed four times by centrifugation (1500 rpm) with lysis buffer. The resins were washed once more in lysis buffer lacking salt and then transferred to a 2-ml siliconized tube. Bound proteins were eluted from the resin by suspension in lysis buffer containing 100 mM imida-

zole, and the supernatant containing the eluted protein was collected by centrifugation. Eluates were stored at –80 C in aliquots and analyzed by Lowry assay for protein concentration, by silver-stained SDS-PAGE for purity, and by Western blot for identification of purified products. CBP_{his} and SRC-1 his were purified using the same procedure except that the lysis buffer contained 2 mM imidazole.

The hLBD-GST fusion protein was purified by glutathione Sepharose affinity chromatography. Whole-cell extracts were made in cell lysis buffer (10 mM Tris-base, pH 8.0, 1 mM EDTA, 1 mM dithiothreitol, and 10% glycerol, containing 350 mM NaCl) as described above and bound to glutathione Sepharose 4B resins (Pharmacia Biotech, Piscataway, NJ) by resuspension in a 50-ml siliconized tube for 2 h on an end-over-end rotator. The resins were washed four times by centrifugation (1500 rpm) with lysis buffer. The resins were washed once more in lysis buffer lacking salt, and then transferred to a 2-ml siliconized tube. Bound proteins were eluted with 20 mM glutathione and collected by centrifugation. Eluted samples were analyzed as described above.

Pull-Down Assays to Detect PR Domain Interactions *in Vitro*

For experiments in crude extracts, Sf9 cells expressing different PR domains were lysed as above, and whole cell extracts were dialyzed against lysis buffer lacking salt. PR hLBD_{his} was treated with EnterokinaseMax (Invitrogen) to cleave off the N-terminal polyhistidine tag as described previously (45). Sf9 whole-cell extracts were added to the hLBD lacking the his-tag, which was then dialyzed against lysis buffer without salt. The hLBD was analyzed by Western blot with the PR-specific MAb C-262 and the anti-his tag MAb (1162/F6) to confirm removal of the his-tag (data not shown). The PR LBD was expressed as a non-his-tagged protein and prepared as whole-cell extracts for Sf9 cells. The LBD or hLBD was incubated with polyhistidine-tagged N-terminal domain polypeptides of PR-A (ANhis), PR-B (BNhis), or buffer, which served as a control for nonspecific binding of non-his LBD or hLBD to metal resins, in siliconized microcentrifuge tubes for 30 min on ice. TG buffer (20 mM Tris-HCl, pH 8.0, plus 10% glycerol) containing 45 mM imidazole and 300 mM NaCl was added to bring the final imidazole concentration to 15 mM imidazole and NaCl to 100 mM. One hundred microliters of a 1:1 suspension of Talon (CLONTECH Laboratories, Inc.) metal affinity resin or Ni-NTA resin (Qiagen) were added to each tube. Samples were then resuspended and incubated in batch at 4 C for 1 h on an end-over-end rotator followed by washing of the resins four times by centrifugation in TG buffer containing 15 mM imidazole and 100 mM NaCl. Resins were transferred to a new microcentrifuge tube and washed twice more. Bound proteins were extracted with 2% SDS sample buffer and electrophoresed on 10% or 7.5% polyacrylamide SDS gels as previously described (45–47). Separated proteins were transferred to nitrocellulose paper and detected by Western blot assays with a mixture of MAbs including C-262 generated against the C terminus and AB-52 generated against the N terminus common to PR-A and PR-B (46, 47). [³⁵S]protein A (Amersham) and autoradiography were used as the detection methods as described previously (45).

For experiments using purified receptors, a GST pull-down assay was developed that was similar to the polyhistidine pull-down assay except for the following modifications. The purified hLBD-GST was bound to 100 μ l of a 1:1 suspension of glutathione Sepharose 4B resin, which had been pre-treated with ovalbumin (5 μ g/100 μ l of resin) for 15 min, on an end-over-end rotator for 1 h at 4 C in TG buffer containing 100 mM NaCl. The resins were washed once by centrifugation with TG buffer containing 100 mM NaCl. Ten micrograms of ovalbumin and either purified ANhis or BNhis were added to the sample. TG buffer containing 300 mM NaCl was added to bring the final concentration of NaCl to 100 mM. Samples

were incubated on an end-over-end rotator for 1 h at 4 C and then washed by centrifugation once with TG containing 100 mM NaCl, twice with TG containing 125 mM NaCl, and once more with TG containing 100 mM NaCl. Resins were transferred to a new microcentrifuge tube and washed twice more with TG containing 100 mM NaCl. Bound proteins were eluted and analyzed as described above for polyhistidine pull-down assay.

Mammalian Two-Hybrid Assay

The PR hLBD (aa 634–933) was cloned as a fusion protein at the amino terminus with Gal4-DBD (aa 1–147) into the pBK-CMV mammalian expression vector (Stratagene, La Jolla, CA) as described previously (11). The amino terminus of PR-A (aa 165–550) and PR-B (aa 1–550) were cloned into the pVP16 fusion vector (CLONTECH Laboratories, Inc.) to yield AN-VP16 and BN-VP16, respectively, as follows: the fusion constructs Gal4-DBD-BN and Gal4-DBD-AN were digested with *EcoRI* and *XbaI*, and the coding sequences for the respective PR domains were ligated into pVP16, previously digested with *EcoRI* and *XbaI*. A control vector for nonspecific protein interaction contained the SV40 large T antigen fused to VP16 (T-VP16) and was purchased from CLONTECH Laboratories, Inc. The luciferase reporter gene contained a TATA box and five copies of the Gal4 DNA-binding sites (5× Gal4-TATA-LUC, a gift from X. F. Wang, Duke University, Durham, NC). Mouse CBP cDNA was excised from pRc/RSV-mCBP-HA-RK (a gift from R. Goodman, Oregon Health Sciences Center, Portland, OR) (60) by digestion with *HindIII* and *NotI*. The full-length CBP cDNA was then inserted into the *HindIII* and *NotI* restriction sites of pCR3.1 mammalian expression vector (Invitrogen) to yield pCR3.1-CBP, which expresses full-length mouse CBP with an HA (hemagglutinin antigen) tag. pCR3.1-SRC-1 and SRC-1(0.8) were gifts from B. W. O'Malley (Baylor College of Medicine). The mammalian expression vector for E1A (pbcl2-E1A12S) was a gift from J. Nevins (Duke University).

HeLa cells and HepG2 cells were maintained in MEM plus 10% FCS (Life Technologies, Gaithersburg, MD). Cells were plated in 24-well dishes (coated with 0.1% gelatin for HepG2 cells) and allowed to grow 24 h before transfection. DNA was introduced into the cells using Lipofectin (Life Technologies). Briefly, triplicate transfections were performed using 3 µg of total DNA. For standard transfections 50 ng of pBKC-β-gal (normalization vector) (61), 500 ng of reporter (5× Gal4-TATA-LUC), 1000 ng of hLBD-Gal4, 1000 ng of VP16 fusion constructs, and 450 ng of pCR3.1, 450 ng pCR3.1-hSRC-1, 450 ng pCR3.1-CBP, or a combination of 225 ng of pCR3.1-CBP and 225 ng of pCR3.1-SRC-1 (total of 450 ng of plasmid) were used. Cells were incubated with Lipofectin for 3 h, at which time media were removed and cells were treated with the appropriate hormone diluted in phenol red-free media containing 10% charcoal-stripped FCS (HyClone Laboratories, Inc., Logan, UT). Incubation with hormone continued for 48 h, after which cells were lysed and assayed for luciferase and β-galactosidase activity as described previously (62).

Data Analysis

Comparisons of results from protein-tagged pull-down and mammalian two-hybrid assays were done by Student's *t* tests or ANOVA using Excel 5.0 (Microsoft Corp.) to determine whether there was a significant difference among groups. Results were considered statistically significant at $P < 0.05$.

Acknowledgments

The authors acknowledge the expert technical assistance of Kurt Christensen, Suzanne Meizner, and Kristen Cullen for

expression of recombinant proteins in the baculovirus insect cell system, the technical assistance of Neal Van Hoven with polyhistidine-tagged pull-down assay, Lori Sherman for purification of baculovirus-expressed proteins, and Vida Melvin for assistance with computer graphics.

Received February 1, 1999. Revision received March 9, 1999. Accepted March 11, 1999.

Address requests for reprints to: Dean P. Edwards, Ph.D., Department of Pathology, B216, University of Colorado Health Sciences Center, 4200 East Ninth Avenue, Denver, Colorado 80262. E-mail: Dean.Edwards@UCHSC.edu.

This research was supported in part by NIH Grant DK-49030 (D.P.E.), NIH Grant DK-50495 (D.P.M.), NIH National Research Service Award Postdoctoral Fellowships DK-09225 (M.J.T.) and DK-09662 (S.A.L.), Linnea Basey Breast Cancer Fellowship (M.J.T.), US Army Medical Research and Materiel Command Predoctoral Fellowship (P.H.G.), and the Tissue Culture CORE facility of the University of Colorado Cancer Center (P30 CA-46934).

*Present address: Center for Neuroendocrine Studies, Tobin Hall, Box 37720, University of Massachusetts, Amherst, Massachusetts 01003.

†Equal contributors to this work and should both be considered as first authors.

REFERENCES

1. Mangelsdorf DJ, Thummel C, Beato M, Herrlich P, Schütz G, Umesono K, Blumberg B, Kastner P, Mark M, Chambon P, Evans RM 1995 The nuclear receptor superfamily: the second decade. *Cell* 83:835–839
2. Tsai MJ, O'Malley BW 1994 Molecular mechanisms of action of steroid/thyroid receptor superfamily members. *Annu Rev Biochem* 63:451–486
3. Kastner P, Krust A, Turcotte B, Stropp U, Tora L, Gronemeyer H, Chambon P 1990 Two distinct estrogen-regulated promoters generate transcripts encoding the two functionally different human progesterone receptor forms A and B. *EMBO J* 9:1603–1614
4. Meyer ME, Pornon A, Ji JW, Bocquel MT, Chambon P, Gronemeyer H 1990 Agonistic and antagonistic activities of RU486 on the functions of the human progesterone receptor. *EMBO J* 9:3923–3932
5. Meyer ME, Quirin-Stricker C, Lerouge T, Bocquel MT, Gronemeyer H 1992 A limiting factor mediates the differential activation of promoters by the human progesterone receptor isoforms. *J Biol Chem* 267:10882–10887
6. Sartorius CA, Melville MY, Hovland AR, Tung L, Takimoto GS, Horwitz KB 1994 A third transactivation function (AF3) of human progesterone receptors located in the unique N-terminal segment of the B-isoform. *Mol Endocrinol* 8:1347–1360
7. Vegeto E, Shahbaz MM, Wen DX, Goldman ME, O'Malley BW, McDonnell DP 1993 Human progesterone receptor A form is a cell- and promoter-specific repressor of human progesterone receptor B function. *Mol Endocrinol* 7:1244–1255
8. McDonnell DP, Goldman ME 1994 RU486 exerts antiestrogenic activities through a novel progesterone receptor A form-mediated mechanism. *J Biol Chem* 269:11945–11949
9. Tung L, Kamel Mohamed M, Hoeffler JP, Takimoto GS, Horwitz KB 1993 Antagonist-occupied human progesterone B-receptors activate transcription without binding to progesterone response elements and are dominantly inhibited by A-receptors. *Mol Endocrinol* 7:1256–1265
10. Wen DX, Xu YF, Mais DE, Goldman ME, McDonnell DP 1994 The A and B isoforms of the human progesterone

- receptor operate through distinct signaling pathways within target cells. *Mol Cell Biol* 14:8356–8364
11. Giangrande PH, Pollio G, McDonnell DP 1997 Mapping and characterization of the functional domains responsible for the differential activity of the A and B isoforms of the human progesterone receptor. *J Biol Chem* 272:32889–32900
 12. Hovland AR, Powell RL, Takimoto GS, Tung L, Horwitz KB 1998 An N-terminal inhibitory function, IF, suppresses transcription by the A-isoform but not the B-isoform of human progesterone receptors. *J Biol Chem* 273:5455–5460
 13. Smith DF, Toft DO 1993 Steroid receptors and their associated proteins. *Mol Endocrinol* 7:4–11
 14. Truss M, Beato M 1993 Steroid hormone receptors: interaction with deoxyribonucleic acid and transcription factors. *Endocr Rev* 14:459–479
 15. DeMarzo A, Beck CA, Oñate SA, Edwards DP 1991 Dimerization of mammalian progesterone receptors occurs in the absence of DNA and is related to the release of the 90-kDa heat shock protein. *Proc Natl Acad Sci USA* 88:72–76
 16. Oñate SA, Tsai SY, Tsai MJ, O'Malley BW 1995 Sequence and characterization of a coactivator for the steroid hormone receptor superfamily. *Science* 270:1354–1357
 17. Edwards DP 1999 Role of coregulatory proteins in nuclear receptor action. *Vitam Horm* 55:165–218
 18. Janknecht R, Hunter T 1996 A growing coactivator network. *Nature* 383:22–23
 19. Hanstein B, Eckner R, DiRenzo J, Halachmi S, Liu H, Searcy B, Kurokawa R, Brown M 1996 p300 is a component of an estrogen receptor coactivator complex. *Proc Natl Acad Sci USA* 93:11540–11545
 20. Hibata H, Spencer TE, Oñate SA, Jenster G, Tsai SY, Tsai MJ, O'Malley BW 1997 Role of coactivators and corepressors in the mechanism of steroid/thyroid receptor action. *Recent Prog Horm Res* 52:141–165
 21. Torchia J, Rose DW, Inostroza J, Kamei Y, Westin S, Glass CK, Rosenfeld MG 1997 The transcriptional coactivator p/CIP binds CBP and mediates nuclear-receptor function. *Nature* 387:677–684
 22. Kamei Y, Xu L, Heinzel T, Torchia J, Kurokawa R, Gloss B, Lin S-C, Heyman RA, Rose DW, Glass CK, Rosenfeld MG 1996 A CBP integrator complex mediates transcriptional activation and AP-1 inhibition by nuclear receptors. *Cell* 85:403–414
 23. Xu J, Qiu Y, Demayo FJ, Tsai SY, Tsai MJ, O'Malley BW 1998 Partial hormone resistance in mice with disruption of the steroid receptor coactivator-1 (SRC-1) gene. *Science* 279:1922–1925
 24. Jenster G, Spencer TE, Burcin MM, Tsai SY, Tsai MJ, O'Malley BW 1997 Steroid receptor induction of gene transcription: a two step model. *Proc Natl Acad Sci USA* 94:7879–7884
 25. Spencer TE, Jenster G, Burcin MM, Allis CD, Zhou J, Mizzen CA, McKenna NJ, Oñate SA, Tsai SY, Tsai MJ, O'Malley BW 1997 Steroid receptor coactivator-1 is a histone acetyltransferase. *Nature* 389:194–197
 26. Chen H, Lin RJ, Schiltz RL, Chakravarti D, Nash A, Nagy L, Privalsky ML, Nakatani Y, Evans RM 1997 Nuclear receptor coactivator ACTR is a novel histone acetyltransferase and forms a multimeric activation complex with P/CAF and CBP/p300. *Cell* 90:569–580
 27. Korzus E, Torchia J, Rose DW, Xu L, Kurokawa R, McInerney EM, Mullen TM, Glass CK, Rosenfeld MG 1998 Transcription factor-specific requirements for coactivators and their acetyltransferase functions. *Science* 279:703–707
 28. Oñate SA, Boonyaratanakornkit V, Spencer TE, Tsai SY, Tsai MJ, Edwards DP, O'Malley BW 1998 The steroid receptor coactivator-1 contains multiple receptor interacting and activation domains that cooperatively enhance the activation function 1 (AF1) and AF2 domains of steroid receptors. *J Biol Chem* 273:12101–12108
 29. Smith CL, Nawaz Z, O'Malley BW 1997 Coactivator and corepressor regulation of the agonist/antagonist activity of the mixed antiestrogen, 4-hydroxytamoxifen. *Mol Endocrinol* 11:657–666
 30. Ikonen T, Palvimo JJ, Janne OA 1997 Interaction between the amino- and carboxyl-terminal regions of the rat androgen receptor modulates transcriptional activity and is influenced by nuclear receptor coactivators. *J Biol Chem* 272:29821–29828
 31. Webb P, Nguyen P, Shinsako J, Anderson C, Feng W, Nguyen MP, Chen D, Huang S-M, Subramanian S, McKinerney E, Katzenellenbogen BS, Stallcup MR, Kushner PJ 1998 Estrogen receptor activation function 1 works by binding p160 coactivator proteins. *Mol Endocrinol* 12:1605–1618
 32. Tora L, White J, Brou C, Tasset D, Webster N, Scheer E, Chambon P 1989 The human estrogen receptor has two independent non-acidic transcriptional activation functions. *Cell* 59:477–487
 33. Lees JA, Fawell SE, Parker MG 1989 Identification of two transactivation domains in the mouse oestrogen receptor. *Nucleic Acid Res* 17:5477–5487
 34. Metzger D, Ali S, Bornert JM, Chambon P 1995 Characterization of the amino-terminal transcriptional activation function of the human estrogen receptor in animal and yeast cells. *J Biol Chem* 270:9535–9542
 35. Bocquel MT, Kumar V, Stricker C, Chambon P, Gronemeyer H 1989 The contribution of the N- and C-terminal regions of steroid receptors to activation of transcription is both receptor- and cell-specific. *Nucleic Acid Res* 17:1007–1019
 36. Tasset D, Tora L, Fromental C, Scheer E, Chambon P 1990 Distinct classes of transcriptional activating domains function by different mechanisms. *Cell* 62:1177–1187
 37. Kumar V, Green S, Stack G, Berry M, Jin JR, Chambon P 1987 Functional domains of the human estrogen receptor. *Cell* 51:941–951
 38. Tzukerman MT, Esty A, Santiso-Mere D, Danielian P, Parker MG, Stein RB, Pike JW, McDonnell DP 1994 Human estrogen receptor transactivational capacity is determined by both cellular and promoter context and mediated by two functionally distinct intramolecular regions. *Mol Endocrinol* 8:21–30
 39. Pham TA, Hwung YP, Santisomere D, McDonnell DP, O'Malley BW 1992 Ligand-dependent and ligand-independent function of the transactivation regions of the human estrogen receptor in yeast. *Mol Endocrinol* 6:1043–1050
 40. Kraus WL, McInerney EM, Katzenellenbogen BS 1995 Ligand-dependent, transcriptionally productive association of the amino- and carboxyl-terminal regions of a steroid hormone nuclear receptor. *Proc Natl Acad Sci USA* 92:12314–12318
 41. Langley E, Zhou Z, Wilson EM 1995 Evidence for an anti-parallel orientation of the ligand-activated human androgen receptor dimer. *J Biol Chem* 270:29983–29990
 42. Doesburg P, Kuil CW, Berrevoets CA, Steketee K, Faber PW, Mulder E, Brinkmann AO, Trapman J 1997 Functional *in vivo* interaction between the amino-terminal, transactivation domain and the ligand binding domain of the androgen receptor. *Biochemistry* 36:1052–1064
 43. Berrevoets CA, Doesburg P, Steketee K, Trapman J, Brinkmann AO 1998 Functional interactions of the AF-2 activation domain core region of the human androgen receptor with the amino-terminal domain and with the transcriptional coactivator TIF2 (transcriptional intermediary factor 2). *Mol Endocrinol* 12:1172–1183

44. McInerney EM, Tsai MJ, O'Malley BW, Katzenellenbogen BS 1996 Analysis of estrogen receptor transcriptional enhancement by a nuclear hormone receptor coactivator. *Proc Natl Acad Sci USA* 93:10069-10073
45. Tetel MJ, Jung S, Carbajo P, Ladtkow T, Skafar DF, Edwards DP 1997 Hinge and amino-terminal sequences contribute to solution dimerization of human progesterone receptor. *Mol Endocrinol* 11:1114-1128
46. Estes PA, Suba EJ, Lawler-Heavner J, Elashry-Stowers D, Wei LL, Toft DO, Sullivan WP, Horwitz KB, Edwards DP 1987 Immunological analysis of human breast cancer progesterone receptors. 1. Immunoaffinity purification of transformed receptors and production of monoclonal antibodies. *Biochemistry* 26:6250-6262
47. Weigel NL, Beck CA, Estes PA, Prendergast P, Altmann M, Christensen K, Edwards DP 1992 Ligands induce conformational changes in the carboxyl-terminus of progesterone receptors which are detected by a site-directed antipeptide monoclonal antibody. *Mol Endocrinol* 6:1585-1597
48. Zhang Y, Beck CA, Poletti A, Edwards DP, Weigel NL 1994 Identification of phosphorylation sites unique to the B form of human progesterone receptor. *In vitro* phosphorylation by casein kinase II. *J Biol Chem* 269:31034-31040
49. Lundblad JR, Kwok RPS, Laurance ME, Harter ML, Goodman RH 1995 Adenoviral E1A-associated protein p300 as a functional homologue of the transcriptional co-activator CBP. *Nature* 374:85-88
50. Allan GF, Leng X, Tsai SY, Wiegell NL, Edwards DP, Tsai MJ, O'Malley BW 1992 Hormone and antihormone induce distinct conformational changes which are central to steroid receptor activation. *J Biol Chem* 267:19513-19520
51. Christensen K, Estes PA, Oñate SA, Beck CA, DeMarzo A, Altmann M, Lieberman BA, St. John J, Nordeen SK, Edwards DP 1991 Characterization and functional properties of the A and B forms of human progesterone receptors synthesized in a baculovirus system. *Mol Endocrinol* 5:1755-1770
52. Beekman JM, Allan GF, Tsai SY, Tsai MJ, O'Malley BW 1993 Transcriptional activation by the estrogen receptor requires a conformational change in the ligand binding domain. *Mol Endocrinol* 7:1266-1274
53. Kallio PJ, Janne OA, Palvimo JJ 1994 Agonists, but not antagonists, alter the conformation of the hormone-binding domain of androgen receptor. *Endocrinology* 134:998-1001
54. Langley E, Kempainen JA, Wilson EM 1998 Intermolecular NH₂-/carboxyl-terminal interactions in androgen receptor dimerization revealed by mutations that cause androgen insensitivity. *J Biol Chem* 273:92-101
55. Cohen-Solac K, Bailly A, Ranch C, Quense M, Milgrom E Specific binding of progesterone receptor to progesterone response elements does not require prior dimerization. *Eur J Biochem* 214:189-195
56. Mohamed MK, Tung L, Takimoto GS, Horwitz KB 1994 The leucine zippers of c-fos and c-jun for progesterone receptor dimerization: A-dominance in the A/B heterodimer. *J Steroid Biochem Mol Biol* 51:241-250
57. Williams SP, Sigler PB 1998 Atomic structure of progesterone complexed with its receptor. *Nature* 393:392-396
58. Tetel MJ, Beck CA, Ladtkow T, Christensen K, Weigel NL, Edwards DP 1997 Functional properties and post-translational modification of steroid hormone receptors in the baculovirus expression system. In: Maramorosch K, Mitsuhashi J (eds) *Invertebrate Cell Culture*. Science Publishers, Enfield, NH, pp 201-210
59. Boonyaratanakornkit V, Melvin V, Prendergast P, Altmann M, Ronfani L, Bianchi ME, Taraseviciene L, Nordeen SK, Allegretto EA, Edwards DP 1998 High-mobility group chromatin proteins 1 and 2 functionally interact with steroid hormone receptors to enhance their DNA binding *in vitro* and transcriptional activity in mammalian cells. *Mol Cell Biol* 18:4471-4487
60. Kwok RPS, Lundblad JR, Chrivia JC, Richards JP, Bachinger HP, Brennan RG, Roberts SGE, Green MR, Goodman RH 1994 Nuclear protein CBP is a coactivator for the transcription factor CREB. *Nature* 370:223-229
61. MacGregor GR, Caskey CT 1989 Construction of plasmids that express *E. coli* β -galactosidase in mammalian cells. *Nucleic Acid Res* 17:2365
62. Norris J, Fan D, Aleman C, Marks JR, Futreal PA, Wiseman RW, Iglehart JD, Deininger PL, McDonnell DP 1995 Identification of a new subclass of alu repeats which can function as estrogen receptor-dependent transcriptional enhancers. *J Biol Chem* 270:22777-22782

